

HAC 371x, HAC 372x, HAC 373x

Robust Programmable
2D Position Sensor Family
with Integrated Capacitors



Copyright, Warranty, and Limitation of Liability

The information and data contained in this document are believed to be accurate and reliable. The software and proprietary information contained therein may be protected by copyright, patent, trademark and/or other intellectual property rights of TDK-Micronas. All rights not expressly granted remain reserved by TDK-Micronas.

TDK-Micronas assumes no liability for errors and gives no warranty representation or guarantee regarding the suitability of its products for any particular purpose due to these specifications.

By this publication, TDK-Micronas does not assume responsibility for patent infringements or other rights of third parties which may result from its use. Commercial conditions, product availability and delivery are exclusively subject to the respective order confirmation.

Any information and data which may be provided in the document can and do vary in different applications, and actual performance may vary over time.

All operating parameters must be validated for each customer application by customers' technical experts. Any mention of target applications for our products is made without a claim for fit for purpose as this has to be checked at system level.

Any new issue of this document invalidates previous issues. TDK-Micronas reserves the right to review this document and to make changes to the document's content at any time without obligation to notify any person or entity of such revision or changes. For further advice please contact us directly.

Do not use our products in life-supporting systems, military, aviation, or aerospace applications! Unless explicitly agreed to otherwise in writing between the parties, TDK-Micronas' products are not designed, intended or authorized for use as components in systems intended for surgical implants into the body, or other applications intended to support or sustain life, or for any other application in which the failure of the product could create a situation where personal injury or death could occur.

No part of this publication may be reproduced, photocopied, stored on a retrieval system or transmitted without the express written consent of TDK-Micronas.

TDK-Micronas Trademarks

- HAL
- 3D HAL

Third-Party Trademarks

All other brand and product names or company names may be trademarks of their respective companies.

License Note

HAC 37xy uses licenses of Fraunhofer Institute for Integrated Circuits IIS.

Contents

Page	Section	Title
5	1.	Introduction
6	1.1.	Major Applications
7	1.2.	General Features
8	1.3.	Device-Specific Features of HAC 371x
8	1.4.	Device-Specific Features of HAC 3715 and HAC 372x
8	1.5.	Device-Specific Features of HAC 373x and HAC 3711
9	2.	Ordering Information
9	2.1.	Device-Specific Ordering Codes
12	3.	Functional Description
12	3.1.	General Function
13	3.2.	Signal Path
14	3.3.	Register Definition
14	3.3.1.	RAM Registers
17	3.3.2.	EEPROM Registers
27	3.4.	Output Linearization
29	3.5.	Functional Safety
29	3.5.1.	Function Safety Manual and Functional Safety Report
29	3.5.2.	Integrated Diagnostic Mechanism
31	3.6.	SENT Output Protocol
31	3.6.1.	6 Data Nibble Frame with Two Fast Channels (H.1 Format SAEJ2716 rev. 4)
32	3.6.2.	3 Data Nibble Frame with One Fast Channel (H.2 Format SAEJ2716 rev. 4)
33	3.6.3.	6 Data Nibble Frame with Secure Information (H.4 Format SAEJ2716 rev. 4)
34	3.6.4.	Error Diagnostic Reporting on Fast Channel
34	3.6.4.1.	Impact of Diagnosis Bit (CUST_SETUP1 - Bit 1) on SENT Output
35	3.6.5.	Timing of error reporting on fast channel
35	3.6.6.	Pause Pulse
35	3.6.7.	CRC Implementation
36	3.6.8.	Slow Channel: Enhanced Serial Message
36	3.6.9.	Slow Channel: Serial Message Sequence
37	3.6.10.	Slow Channel: Serial Message Error Codes
38	3.6.11.	Slow Channel: Sensor Types
38	3.6.12.	Start-Up behavior
39	3.6.13.	Message Time for SENT Frames with Pause Pulse
41	4.	Specifications
41	4.1.	Outline Dimensions

Contents, continued

Page	Section	Title
43	4.2.	Soldering, Welding, Assembly
43	4.3.	Storage and Shelf Life package
43	4.4.	Size of Sensitive Area
43	4.5.	Definition of Magnetic-Field Vectors
44	4.6.	Pin Connections and Short Description
45	4.7.	Absolute Maximum Ratings
46	4.8.	Recommended Operating Conditions
47	4.9.	Characteristics
52	4.10.	Magnetic Characteristics
54	5.	Application Notes
54	5.1.	Ambient Temperature
54	5.2.	EMC and ESD
55	5.3.	Application Circuit for HAC 3715 and HAC 372x
55	5.4.	Application Circuit for HAC 3711 and HAC 373x
56	5.5.	Measurement of a PWM Output Signal of HAC 3711 and HAC 373x
57	6.	Programming of the Sensor
57	6.1.	Programming Interface
58	6.2.	Programming Environment and Tools
58	6.3.	Programming Information
59	7.	Document History

Robust Programmable 2D Position Sensor Family with Integrated Capacitors

Release Note: Revision bars indicate significant changes to the previous edition.

1. Introduction

HAC 37xy is a new family of 2D position sensors offering optimal protection against electromagnetic interference. This EMC-optimized Hall sensor family comprises the second generation of 2D position sensors using TDK-Micronas' proprietary 3D HAL® technology. Decoupling capacitors are already integrated into the three-lead TO package.

HAC 372x provides a linear, ratiometric analog output signal with integrated wire-break detection working with a pull-up or pull-down resistor. Compared to HAC 372x, the HAC 371x splits the 360° measurement range either into four repetitive 90° (MOD 90°) or three 120° (MOD 120°) segments.

HAC 373x and HAC 3711 feature digital output formats like PWM and SENT according SAEJ2716 standard. The digital output format is customer programmable. In SENT mode, the sensor transmits SENT messages with and without pause pulse according to SAEJ2716 rev. 4. The PWM output is configurable with frequencies between 0.2 kHz and 2 kHz with up to 12-bit resolution.

With its integrated capacitors, HAC 37xy meets the stringent ESD and EMC requirements and eliminates the need for a PCB, thus reducing the total system size and cost.

Conventional planar Hall technology is only sensitive to the magnetic field orthogonal to the chip surface. In addition to the orthogonal magnetic field, HAC 37xy is also sensitive to magnetic fields applied in parallel to the chip surface. This is possible by integrating vertical Hall plates into the standard CMOS process.

The sensor cell can measure three magnetic-field components B_x , B_y , and B_z . This enables a new set of applications for position detection, like wide distance, angle or through-shaft angular measurements.

Table 1–1: HAC 37xy family members

Type	Output Format	Detectable Field Component
HAC 3711	PWM & SENT/Modulo	B_x and B_y
HAC 3715	Analog/Modulo	B_x and B_y
HAC 3725	Analog	B_x and B_y
HAC 3726	Analog	B_y and B_z
HAC 3727	Analog	B_x and B_z
HAC 3735	PWM & SAEJ2716 SENT	B_x and B_y
HAC 3736	PWM & SAEJ2716 SENT	B_y and B_z
HAC 3737	PWM & SAEJ2716 SENT	B_x and B_z

On-chip signal processing calculates the angle out of two magnetic-field components and converts this value to an output signal. Due to the measurement method, the sensor exhibits excellent drift performance over the specified temperature range resulting in a new class of accuracy for angular or linear measurements.

Additionally to the built-in signal processing, the sensor features an arbitrary programmable linear characteristic for linearization of the output signal (with up to 33 setpoints).

Major characteristics like gain and temperature dependent offset of X/Y- and Z-channel, reference position, phase shift between X/Y- and Z-signal, hysteresis, low-pass filter frequency, output slope, and offset and clamping levels can be adjusted to the magnetic circuitry by programming the non-volatile memory.

The sensor contains advanced on-board diagnostic features that enhance fail-safe detection. In addition to standard checks, such as overvoltage and undervoltage detection as well as wire breaks, internal blocks such as ROM and signal path are monitored during normal operation. For devices with a selected PWM output, the error modes are indicated by changing the PWM frequency and the duty-cycle. For SENT output a dedicated error code will be transmitted.

This product is defined as SEooC (Safety Element out of Context) ASIL B ready according to ISO 26262.

The devices are designed for automotive and industrial applications. They operate in the ambient temperature range from -40 °C to 150 °C .

The sensors are available in a small three-pin leaded transistor package TO92UF.

1.1. Major Applications

Thanks to the sensor's versatile programming characteristics and its high accuracy, the HAC 37xy is a potential solution for the following application examples:

- Linear movement measurement,
 - EGR valve position
 - Transmission position
 - Cylinder and valve position sensing
- Rotary position measurement, like
 - Gear selector
 - Turbo-charger
 - Throttle valve position, etc.
 - Chassis position sensors (ride-height control) with HAC 371x
- Non-contact potentiometer

1.2. General Features

- Angular and position measurement extremely robust against temperature and stress influence
- Integrated capacitors for robust Electromagnetic Compatibility (EMC) and PCB-less applications
- Programmable arbitrary output characteristic with up to 33 setpoints
- SEooC ASIL B ready according to ISO 26262 to support Functional Safety applications
- 8 KSps sampling frequency
- Operates from 4.5 V up to 5.5 V supply voltage
- Programming via the sensor's output pin
- Programmable characteristics in a non-volatile memory with redundancy and lock function
- Programmable first-order low-pass filter, as well as DNC filter
- Programmable output gain and offset
- X/Y- and Z-channel gain of signal path programmable
- Second-order temperature dependent offset of signal path programmable for X/Y- or Z-channel
- Phase shift between X/Y- and Z-channel programmable
- Programmable offset before angle calculation block
- Programmable output clamping for error band definition
- Programmable reference position
- Programmable magnetic detection range
- 32-bit identification number for customer
- 32-bit identification number with TDK-Micronas production information (like X,Y position on the wafer, etc.)
- On-board diagnostics of different functional blocks of the sensor
- Short-circuit protected push-pull output
- Over- and reverse-voltage protection at V_{SUP}
- Under- and overvoltage detection of V_{SUP}
- EMC and ESD robust package design

1.3. Device-Specific Features of HAC 371x

- Modulo 90°/120°

1.4. Device-Specific Features of HAC 3715 and HAC 372x

- 12-bit ratiometric linear analog output
- Wire-break detection with pull-up or pull-down resistor
- Interpolator for D/A converter analog output

1.5. Device-Specific Features of HAC 373x and HAC 3711

- Customer selectable PWM or SENT output
- 0.2 kHz to 2 kHz PWM (up to 12 bits)
- Push-pull or open-drain output
- SENT according to SAEJ2716 rev. 4
- Support of three different SENT frame formats:
 - Secure sensor information with 3 data nibbles 12-bit position information and 3 data nibbles 12-bit secure sensor information
 - 3 data nibbles with 12-bit position information and 3 data nibbles with 12-bit temperature information or 12-bit magnetic-field amplitude
 - 3 data nibbles with 12-bit position information
 - Enhanced 8-bit ID serial message format including temperature information
 - Programmable tick time between 0.5 μ s and 4.25 μ s in 0.25 μ s steps
 - Low time of 5 ticks

2. Ordering Information

- A TDK-Micronas device is available in a variety of delivery forms. They are distinguished by a specific ordering code:

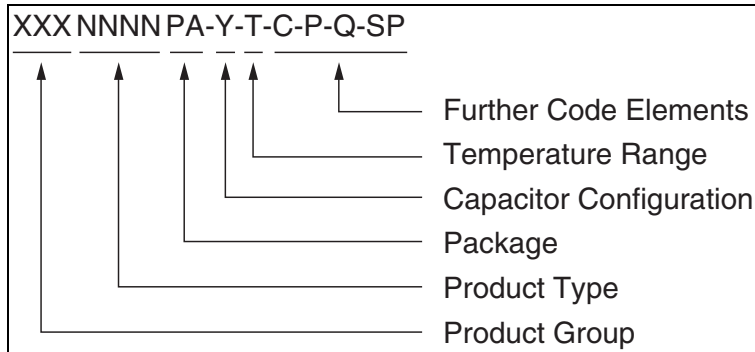

Fig. 2–1: Ordering Code Principle

For a detailed information, please refer to the brochure:

- “Sensors and Controllers: Ordering Codes, Packaging, Handling”.

2.1. Device-Specific Ordering Codes

The HAC 37xy is available in the following package, capacitor, and temperature variants.

Table 2–1: Available packages

Package Code (PA)	Package Type
CX	TO92UF-2

Values of the capacitors from VSUP to GND and OUT to GND are uniquely identified by a letter added within the Hall sensor package code, according to the description in Fig. 2–1.

Table 2–2: Available capacitor configurations

Capacitance Code (Y)	Capacitor from VSUP to GND	Capacitor from OUT to GND	Available for Device
J	100 nF	100 nF	HAC 3715, HAC 372x
W	330 nF	100 nF	HAC 3715, HAC 372x
H	100 nF	1 nF	HAC 3711, HAC 373x
R	330 nF	1 nF	HAC 3711, HAC 373x

Table 2–3: Available temperature ranges

Temperature Code (T)	Temperature Range
A	$T_J = -40\text{ °C to }170\text{ °C}$

The relationship between ambient temperature (T_A) and junction temperature (T_J) is explained in Section 5.1. on page 54.

For available variants for Configuration (C), Packaging (P), Quantity (Q), and Special Procedure (SP) please contact TDK-Micronas.

Table 2–4: Available ordering codes

Available Ordering Codes	Capacitor Combination [Y]
HAC3715CX[Y]A-[C-P-Q-SP]	J or W
HAC3725CX[Y]A-[C-P-Q-SP]	J or W
HAC3726CX[Y]A-[C-P-Q-SP]	J or W
HAC3727CX[Y]A-[C-P-Q-SP]	J or W
HAC3711CX[Y]A-[C-P-Q-SP]	H or R
HAC3735CX[Y]A-[C-P-Q-SP]	H or R
HAC3736CX[Y]A-[C-P-Q-SP]	H or R
HAC3737CX[Y]A-[C-P-Q-SP]	H or R

Marking Code

The HAC 37xy devices have a marking on the package surface (branded side). This marking includes the name of the sensor, the capacitor configuration, the date code and, as an option the Special Procedure “SB” number.

Table 2–5: Package Marking for HAC 37xy

Type	Package Marking
HAC 3736HA Temperature Range A Line 1: Product Type / Capacitor Configuration Line 2: Date code / Special Procedure SB (optional) Line 2: Lot number Line 3: Trace code	

3. Functional Description

3.1. General Function

HAC 371x, HAC 372x, and HAC 373x are 2D position sensors based on TDK-Micronas' 3D HAL technology. The sensors include two vertical and one horizontal Hall plate with spinning current offset compensation for the detection of X, Y or Z magnetic-field components, a signal processor for calculation and signal conditioning of two magnetic-field components, protection devices, and a ratiometric linear analog, PWM or SAEJ2716 SENT output.

The spinning-current offset compensation minimizes the errors due to supply voltage and temperature variations as well as external package stress.

The signal path of HAC 37xy consists of two channels (CH1 and CH2). Depending on the product variant two out of the three magnetic-field components are assigned to Channel 1 and Channel 2.

The sensors can be used for angle measurements in a range between 0° and 360° (end-of-shaft and through-shaft setup) as well as for robust position detection (linear movement or position). The in-system calibration can be utilized by the system designer to optimize performance for a specific system. The calibration information is stored in an on-chip EEPROM.

The HAC 37xy is programmable by modulation of the output voltage. No additional programming pin is needed.

To improve EMC performance HAC 37xy integrates two capacitors within the package, between VSUP and GND respectively OUT and GND.

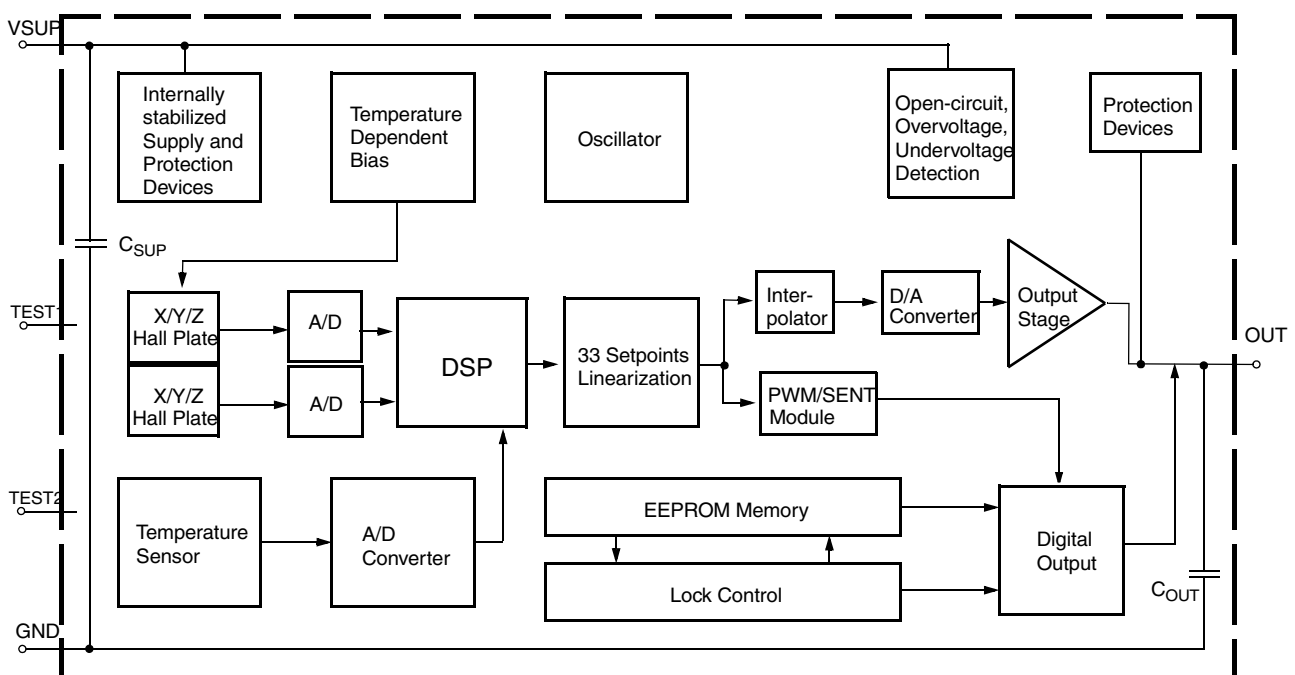

Fig. 3–1: HAC 37xy block diagram

3.2. Signal Path

The DSP part of this sensor performs the signal conditioning. The parameters for the DSP are stored in the memory registers. Details of the signal path are shown in Fig. 3.2.

Terminology:

GAIN: name of the register or register value

Gain: name of the parameter

Blue color: register names

The sensor signal path contains two kinds of registers. Registers that are readout only (RAM) and programmable registers EEPROM. The RAM registers contain measurement data at certain steps of the signal path and the EEPROM registers have influence on the sensors signal processing.

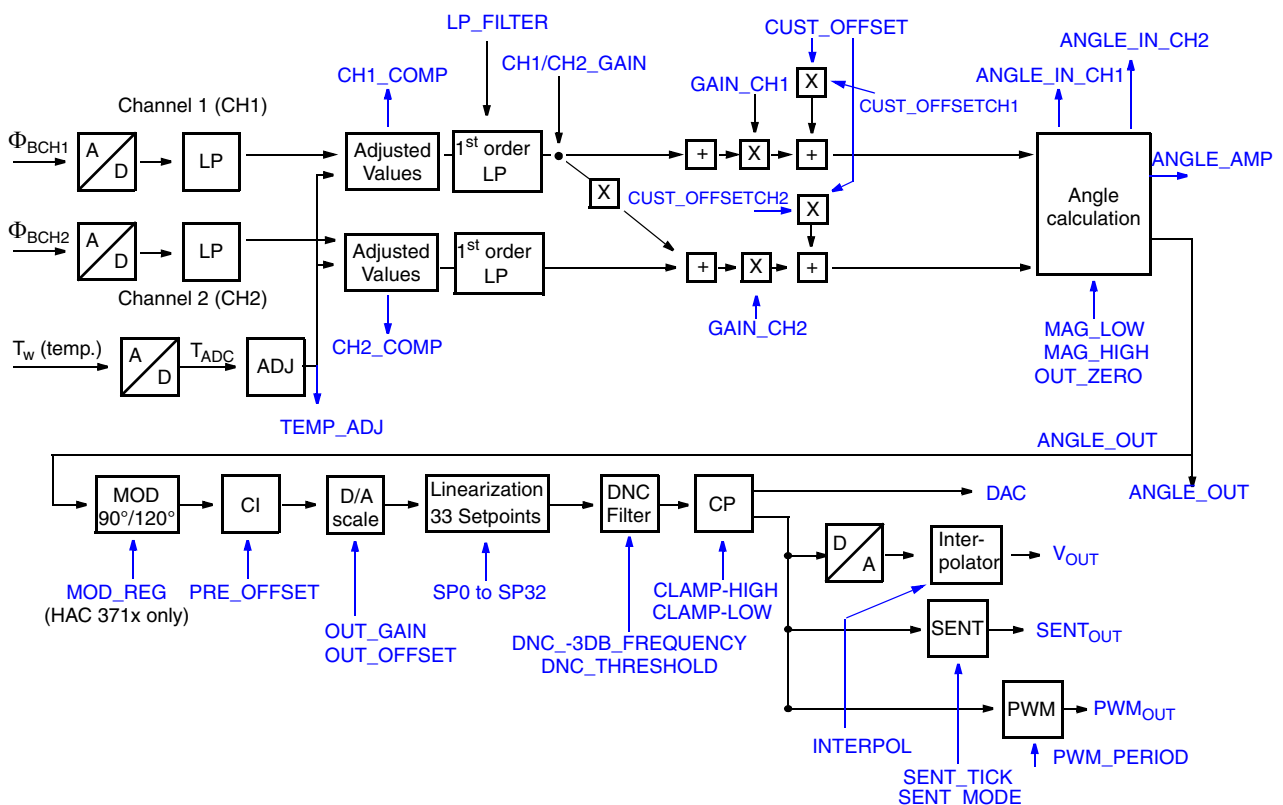

Fig. 3–2: Signal path of HAC 37xy

3.3. Register Definition

3.3.1. RAM Registers

TEMP_ADJ

The TEMP_ADJ register contains the digital value of the sensor junction temperature. It has a length of 16 bits and is binary coded. From the 16 bits only the range between 0 ... 32767 is used for the temperature information. Typically the temperature sensor is calibrated in the way that at -40°C the register value is 100 LSB and at 160°C it is 12000 LSB.

CH1_COMP and CH2_COMP

CH1_COMP and CH2_COMP register contain the temperature compensated magnetic-field information of channel 1 and channel 2. Both registers have a length of 16 bits each and are two's-complement coded. Therefore, the register values can vary between $-32768 \dots 32767$.

ANGLE_IN_CH1 and ANGLE_IN_CH2

ANGLE_IN_CH1 and ANGLE_IN_CH2 register contain the customer compensated magnetic-field information of channel 1 and channel 2 used for the angle calculation. These registers include already customer phase-shift, gain and offset correction. Both registers have a length of 16 bits each and are two's-complement coded. Therefore, the register values can vary between $-32768 \dots 32767$.

ANGLE_OUT

The ANGLE_OUT register contains the digital value of the position calculated by the angle calculation algorithm. It has a length of 16 bits and is binary. From the 16 bits only the range between 0 ... 32767 is used for the position information. Position can either be an angular position (angle) or a virtual angle calculated out of two magnetic-field directions in case of linear position measurements.

DAC

The DAC register contains the digital equivalent of the output voltage, PWM output duty-cycle or the SENT data. It has a length of 16 bits and is binary. From the 16 bits only the range between 0 ... 32767 is used for the position information. Position can either be an angular position (angle) or a virtual angle calculated out of two magnetic-field directions in case of linear position measurements.

ANGLE_AMP

The ANGLE_AMP register contains the digital value of the magnetic-field amplitude calculated by the angle calculation algorithm. The device features two different algorithms for the amplitude calculation. The selection of the calculation depends on the content of the CUST_OFFSETCH1 and CUST_OFFSETCH2 registers. In case that both registers have the value zero (zero = customer offset switched off) the calculation is done by the following equation:

$$\text{ANGLE_AMP} \cong 1.6 \times \sqrt{\text{ANGLE_IN_CH1}^2 + \text{ANGLE_IN_CH2}^2}$$

The amplitude is calculated from the signals in channel 1 and channel 2 (X-/Y-/Z-components). The angle calculation algorithm adds a factor of roughly 1.6 to the equation for the magnetic amplitude.

In case that the customer offset is activated (CUST_OFFSETCH1 or CUST_OFFSETCH2 equal to 32767) the amplitude is calculated by the following equation:

$$\text{ANGLE_AMP} = |\text{ANGLE_IN_CH1}| + |\text{ANGLE_IN_CH2}|$$

DIAGNOSIS

The DIAGNOSIS register identifies certain failures detected by the sensor. HAC 37xy performs self-tests during power-up as well as continues system integrity tests during normal operation. The result of those tests is reported via the DIAGNOSIS register. DIAGNOSIS register is a 16-bit register.

Table 3–1: DIAGNOSIS register

Bit No.	Function	Description
15:13	None	Reserved
12	Internal Supply Voltage Monitor	This bit is set to 1 in case that the internal stabilized voltage is too low.
11	ADC Stuck Error	This bit is set to 1 in case that one of the two A/D converters' signals is stuck at a fixed value.
10	None	Reserved
9	DAC Output High Clamping	This bit is set to 1 in case that the high clamping value of the DAC is reached.
8	DAC Output Low Clamping	This bit is set to 1 in case that the low clamping value of the DAC is reached.
7	Channel 1 Clipping	These bits are set to 1 in case that the A/D converter in channel 1 and/or 2 detects an under- or overflow
6	Channel 2 Clipping	
5	DSP Self Test	The DSP is doing the internal signal processing like angle calculation, temperature compensation, etc. This bit is set to 1 in case that the DSP self test fails. (Continuously running)
4	EEPROM Self Test	This bit is set to 1 in case that the EEPROM self test fails. (Continuously running)
3	ROM Check	This bit is set to 1 in case that ROM parity check fails. (Continuously running)
2	Temperature Sensor Error	This bit is set to 1 in case that the temperature sensor does not deliver valid temperature information.
1	MAGHI	This bit is set to 1 in case that the magnetic field is exceeding the MAG-HI register value (magnetic field too high)
0	MAGLO	This bit is set to 1 in case that the magnetic field is below the MAG-LOW register value (magnetic field too low)

Details on the sensor self tests can be found in Section 3.5. on page 29.

PROG_DIAGNOSIS

The PROG_DIAGNOSIS register allows the customer to identify errors occurring during programming and writing of the EEPROM. The customer must check the first and second acknowledge. To enable debugging of the production line it is recommended to read back the PROG_DIAGNOSIS register in case of a missing second acknowledge. Please check the Programming Guide for HAC 37xy for further details.

The PROG_DIAGNOSIS register is a 16-bit register. The following table shows the different bits indicating certain error possibilities.

Table 3–2: PROG_DIAGNOSIS register

Bit No.	Function	Description
15:11	None	Reserved
10	Charge Pump Error	This bit is set to 1 in case that the internal programming voltage was too low
9	Voltage Error during Program/Erase	This bit is set to 1 in case that the internal supply voltage was too low during program or erase
8:0	None	Reserved

3.3.2. EEPROM Registers

Note For production and qualification tests it is mandatory to set the LOCK bit after final adjustment and programming of HAC 37xy. After locking the device it is still possible to read all memory content.

Note Please refer to the “HAC 37xy User Manual” for further details on register settings/calculation and programming of the device.

Micronas IDs

The MIC_ID1 and MIC_ID2 registers are both 16-bit organized. They are read only and contain TDK-Micronas production information, like X,Y position on the wafer, wafer number, etc.

Customer IDs

The CUST_ID1 and CUST_ID2 registers are both 16-bit organized. These two registers can be used to store customer production information, like serial number, project information, etc.

Low-Pass Filter

With the LP_FILTER register it is possible to select different -3dB frequencies for HAC 37xy. The Low-Pass Filter is a 1st-order digital filter and the register is 16-bit organized. Various typical filter frequencies between 4 kHz (no filter) and 10 Hz are available.

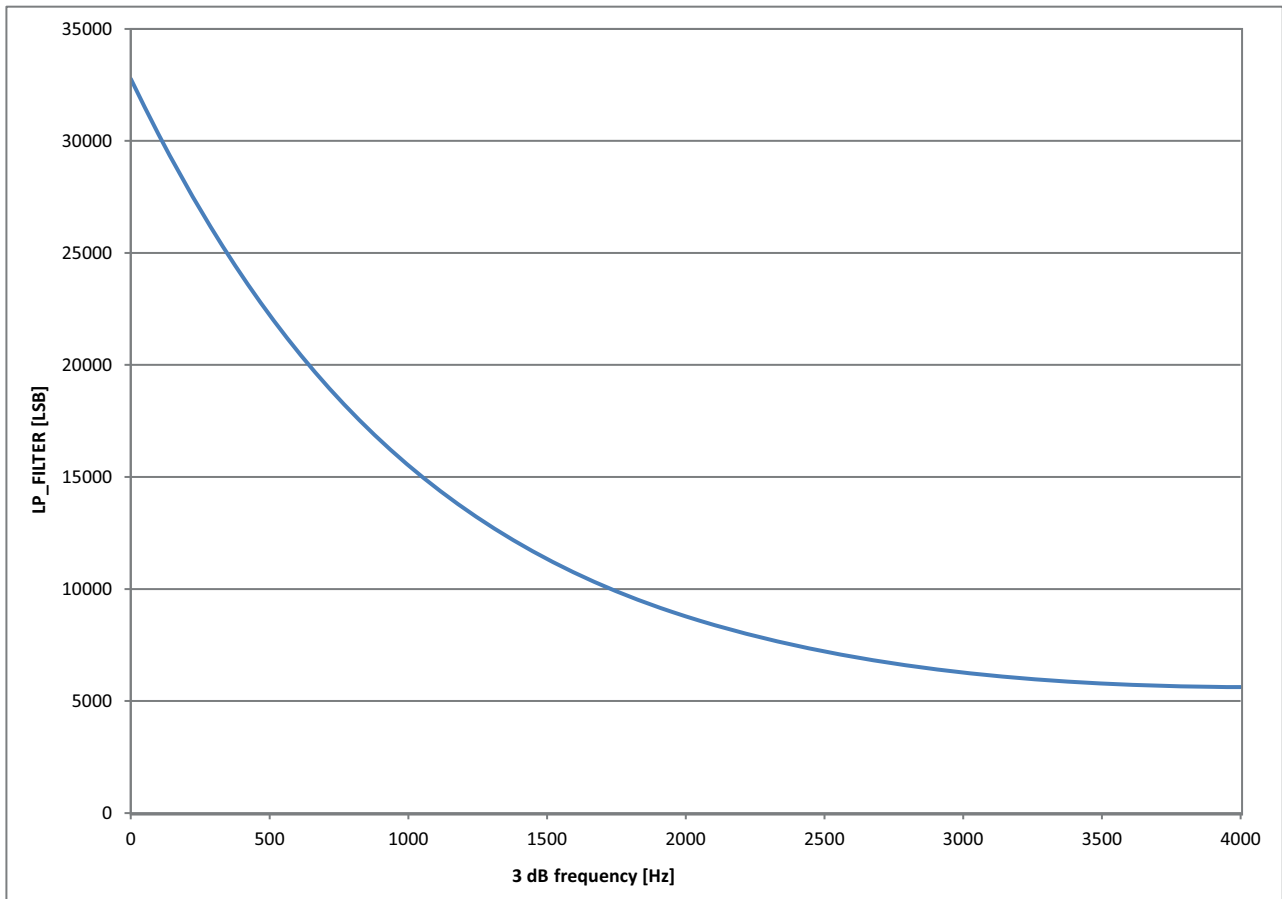

Fig. 3-3: 3dB filter frequency vs. LP_FILTER codes

CH1/CH2_GAIN

CH1/CH2_GAIN can be used to compensate a phase-shift between channel 1 and channel 2. The register has a length of 16 bits. It is possible to make a phase shift correction of $\pm 75^\circ$. The step size and therefore the smallest possible correction is 0.002° . The register is two's-complement coded and ranges from -32768 to 32767 . The register value is sin function based.

Neutral value for this register is zero (no Phase-shift correction).

Note In case the phase-shift correction is used, then it is necessary to adapt the settings of GAIN_CH2 too. For details see definition of GAIN_CH2.

Gain for Channel 1 and 2

GAIN_CH1 and GAIN_CH2 can be used to compensate amplitude mismatches between channel 1 and channel 2. TDK-Micronas delivers pre calibrated sensors with compensated gain mismatch between channel 1 and channel 2. Nevertheless it is possible that due to the magnetic circuit a mismatch between channel 1 and channel 2 gain occurs. This can be compensated with GAIN_CH1 and GAIN_CH2.

Both registers have a length of 16 bits and are two's-complement coded. Therefore, they can have values between -32768 and 32767 ($-2 \dots 2$). For neutral settings both register values have to be set to 1 (register value 16384).

In case that the phase-shift correction is used it is necessary to change also the gain of channel 2 (see also CH1/CH2_GAIN). If phase-shift correction is used the corresponding register has to be set to

$$\text{GAIN_CH2} = \frac{16384}{\cos(\text{Phase-shift})}$$

Note In case GAIN_CH1 or GAIN_CH2 exceed the range of $-2 \dots 2$ ($-32768 \dots 32767$), then it is possible to reduce the gain of the opposite channel for compensation.

Customer Offset

CUST_OFFSET can be used to compensate an offset in channel 1 and channel 2. TDK-Micronas delivers pre calibrated sensors. Nevertheless it is possible that due to the magnetic circuit an offset in channel 1 and channel 2 occurs. This can be compensated with CUST_OFFSET.

The customer offset can also have a temperature coefficient to follow the temperature coefficient of a magnet. The customer offset consists of a polynomial of second-order represented by the three registers CUST_OFFSET1...3.

The customer offset can be added to channel 1 and/or channel 2 by the selection coefficients CUST_OFFSETCH1 and CUST_OFFSETCH2. Additionally these two registers can be used to scale the temperature dependent offset between 0% and 100%

All five registers have a length of 16 bits and are two's-complement coded. Therefore, they can have values between -32768 and 32767 .

Output Signal Zero Position

OUT_Zero defines the reference position for the angle output. It can be set to any value of the output range. It is the starting point/reference for the 33 setpoints. OUT_ZERO has a register length of 16 bits and it is two's-complement coded.

Note Before reading ANGLE_OUT it is necessary to set OUT_ZERO to 0.



Fig. 3–4: Example definition of zero degree point

Secondly this angle can be used to shift the PI discontinuity point of the angle calculation to the maximum distance from the required angular range in order to avoid the 360°-wrapping of the output due to noise.

Magnetic Range Check

The magnetic range check uses the magnitude output and compares it with an upper and lower limit threshold defined by the registers MAG-LOW and MAG-HIGH. If either low or high limit is exceeded then the sensor will indicate it with an overflow on the sensors output (output high clamping).

Mag-Low Limit

MAG-LOW defines the low level for the magnetic-field range check function. This register has a length of 16 bits and is two's complement number.

Mag-High Limit

MAG-HIGH defines the high level for the magnetic-field range check function. This register has a length of 16 bits and is two's complement number.

Modulo Select

The MOD_REG register is only available in HAC 371x. With this register, the customer can switch between Modulo 90° and 120° output.

HAC 371x is splitting the 360° measurement range either into four repetitive 90° (MOD 90°) or three 120° (MOD120°) segments.

Pre Offset

The PRE_OFFSET register allows to shift the angular range/the calculated angles into a new angle region to avoid an overflow of the D/A converter output signal.

The PRE_OFFSET register has a length of 16 bits and is two's-complement coded.

Output Gain

OUT_GAIN defines the gain of the output signal. The register has a length of 16 bits and is two's-complement coded. OUT_GAIN = 1 is neutral setting and leads to a change of the output signal from 0% to 100% for an angle change from 0° to 360° (if OUT_OFFSET is set to 0).

OUT_GAIN can be changed between -64 and 64.

Output Offset

OUT_OFFSET defines the offset of the output signal. The register has a length of 16 bits and is two's complement coded. OUT_OFFSET = 0 is neutral setting and leads to a change of the output signal from 0% to 200% of V_{SUP} for an angle change from 0° to 360° (If OUT_GAIN is set to 1).

OUT_Offset can be changed between -200% and 200% of V_{SUP} . OUT_OFFSET = 0 leads to a voltage offset of 0% of V_{SUP} and OUT_OFFSET = 32768 leads to a offset of -200% of V_{SUP} .

Clamping Levels (CLAMP-LOW & CLAMP-HIGH)

The clamping levels CLAMP_LOW and CLAMP_HIGH define the maximum and minimum output voltage of the output signal. The clamping levels can be used to define the diagnosis band for the sensor output. Both registers have a length of 16 bits and are two's-complemented coded. Both clamping levels can have values between 0% and 100% of V_{SUP} .

Interpolator

HAC 3715 and HAC 372x feature a programmable interpolator before the D/A converter. The interpolator provides a linear interpolation between two successive 8 kHz samples, resulting in an increased update rate (32 x 8 kHz) at the input of the DAC.

The benefit of this block are reduced amplitude steps by a factor of 32, resulting in a smoother analog signal at the output of the DAC and reduced out-of-band noise (>8 kHz).

Please note, that the interpolator does not change the overall bandwidth. The overall bandwidth is defined by the 8 kHz sampling rate of the A/D converter.

The interpolator can be switched on and off with bit 15 in the Customer Setup register 1 (CUST_SETUP 1).

Fig. 3–5 on page 22 shows the Interpolation of a linear output signal.

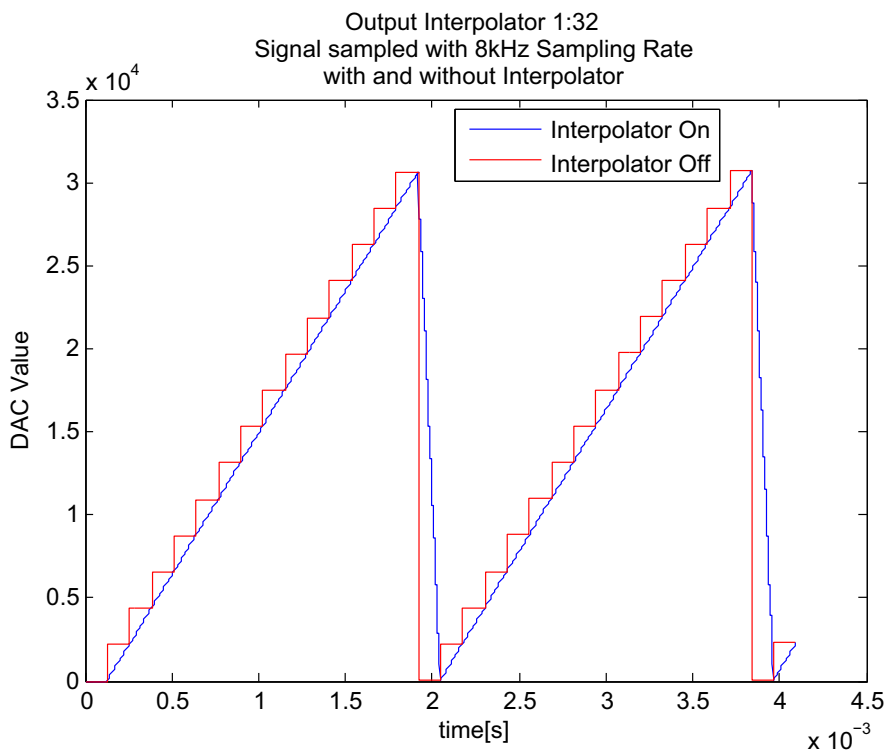

Fig. 3–5: Interpolation of output signal

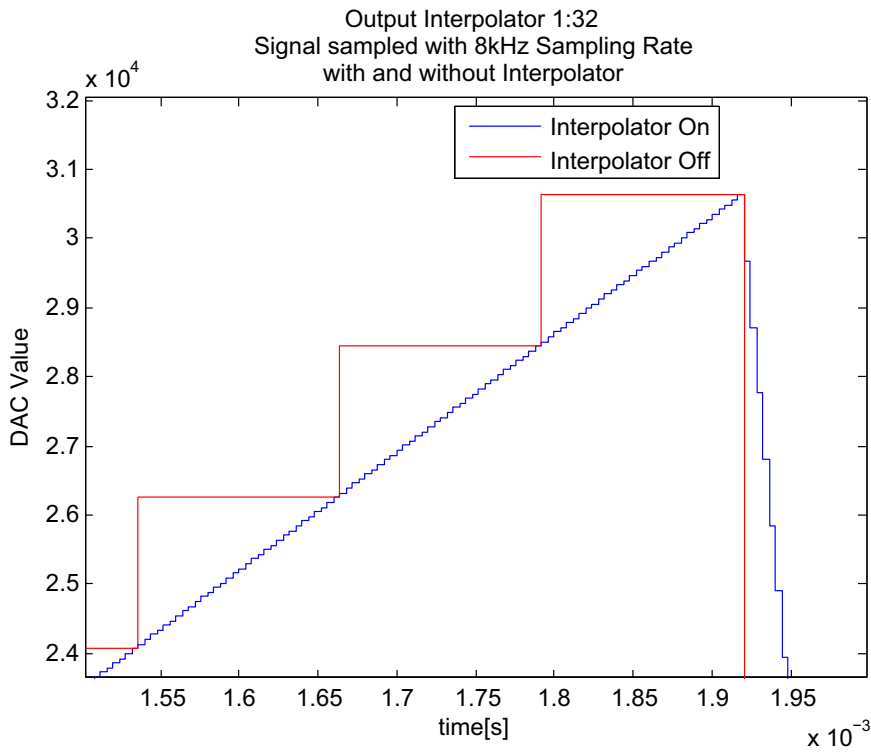

Fig. 3-6: Interpolation of output signal (Zoom view)

DNC filter registers (DNC_-3DB_FREQUENCY & DNC_THRESHOLD)

- The DNC (Dynamic Noise Cancellation) filter can be used for further noise reduction in addition to the first order low-pass filter after the A/D converter. It decreases the output noise significantly by adding a low pass filter with a very low cut-off frequency for signals below a certain signal change threshold (DNC_THRESHOLD).
- The attenuation factor of this IIR filter can be selected by the register DNC_-3dB_FREQUENCY. The threshold can be selected by the register DNC_THRESHOLD. Both registers have a length of 16 bits and are two's complement coded. For DNC_THRESHOLD only values between -1 and -32768 are allowed. To disable the DNC filter DNC_THRESHOLD must be set to 0. For DNC_-3dB_FREQUENCY only positive values between 1 and 32767 are allowed. Recommended is a value of 2048.

Fig. 3–7 is showing the frequency response of the filter (as long as the signal change does not cross the selected DNC_THRESHOLD value) at some recommended filter settings.

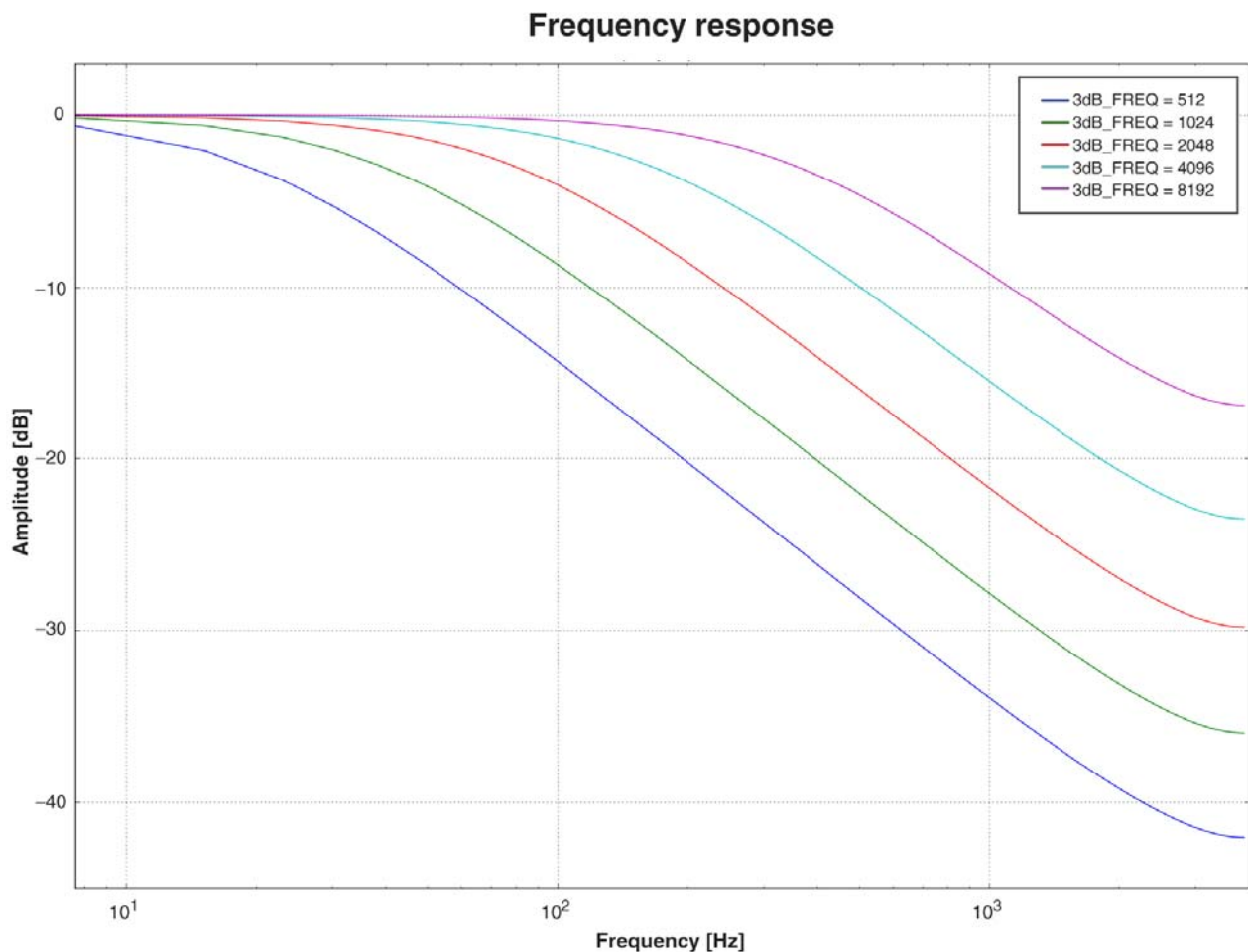

Fig. 3–7: DNC filter low-pass characteristic

Customer Setup Registers (CUST_SETUP1 & 2)

CUST_SETUP1 and CUST_SETUP2 registers are 16-bit registers that enables the customer to activate various functions of the sensor. CUST_SETUP1 is used to select functions like diagnosis modes, functionality mode, customer lock, etc. CUST_SETUP2 can be used to configure the PWM or SENT output.

Table 3–3: Customer Setup Register 1

Bit No.	Function	Description
15	INTERPOL	Analog output interpolator (HAC 3715 and HAC 372x only) 0: Switched off 1: On, interpolation in 32 steps
14	Reserved	Must be set to zero
13	SENT Channel 2	Defines if the device transmits temperature or magnetic field strength information in fast channel 2 in case of H.1 format 0: Transmission of temperature information 1: Transmission of magnetic-field amplitude
12	Digital mode	Output format for HAC 373x and HAC 3711 devices 0: PWM output 1: SENT output
11:10	Reserved	Must be set to zero
9:8	Overcurrent Detection	0: Overcurrent detection OUT = tristate If Customer Lock = 1 1: Overcurrent detection OUT = VSUP (in case of analog output) 2: Overcurrent detection OUT = GND (in case of analog output) else OUT = tristate 3: Overcurrent detection OUT = tristate
7	Error Band	Error band selection HAC 3715 and HAC 372x: 0: High error band (VSUP) 1: Low error band (GND) Error band selection HAC 3711 and HAC 373x: 0: OUT = SENT (error code 4091) / PWM (freq. = 50% and DC = 75%) in case of overvoltage 1: OUT = GND in case of over voltage
6	Burn-In Mode	0: Disabled 1: Enabled
5	Functionality Mode	0: Extended 1: Normal (see Section 4.9. on page 47)
4	SENT Start-Up	Defines if the device transmits during start-up in SENT mode zero samples or 4094 until first valid sample available 0: Transmission of 4094. Always no transmission of error bits in status nibble 1: Transmission of zero samples
3	Overvoltage Detection	0: Overvoltage detection active 1: Overvoltage detection disabled
2	Diagnosis Latch	Latching of diagnosis bits 0: No latching 1: Latched till next POR (power-on reset)
1	Diagnosis	0: Show diagnostic errors on the output 1: Don't show diagnostic errors on the output
0	Customer Lock	Bit must be set to 1 to lock the sensor memory

3.4. Output Linearization

In certain applications (e.g. through shaft applications or position measurements) it is required to linearize the output characteristic. The resulting output characteristic “value vs. angle/position” is not a linear curve as in the ideal case. But it can be linearized by applying an inverse nonlinear compensation curve.

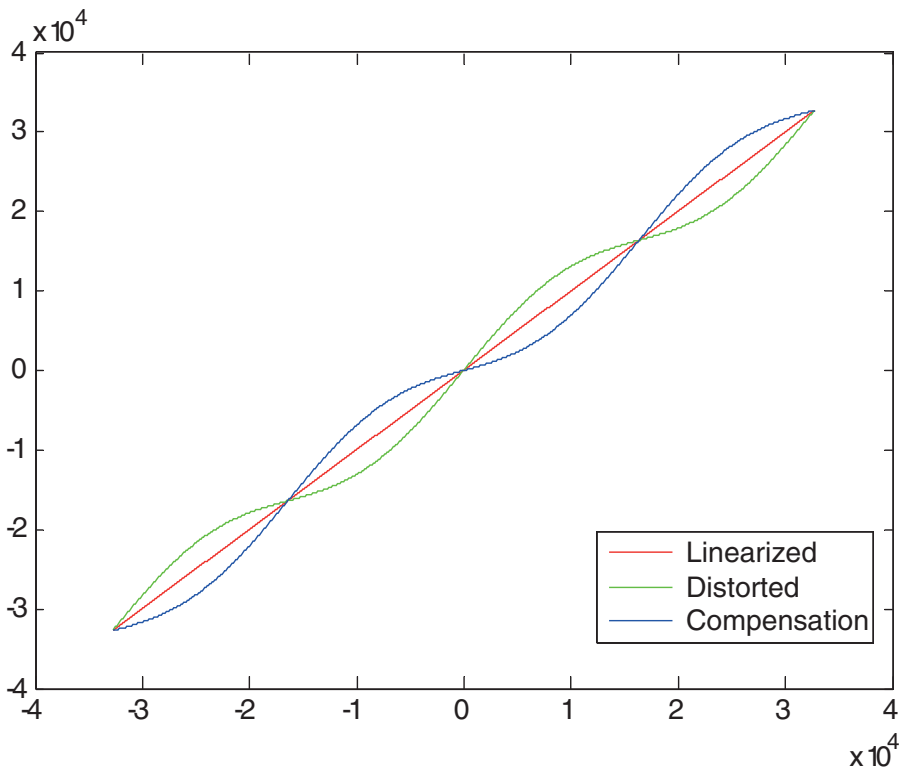

Fig. 3–8: Example for output linearization

For this purpose the compensation curve will be divided into 33 segments with equal distance. Each segment is defined by two setpoints, which are stored in EEPROM. Within the interval, the output is calculated by linear interpolation according to the position within the interval.

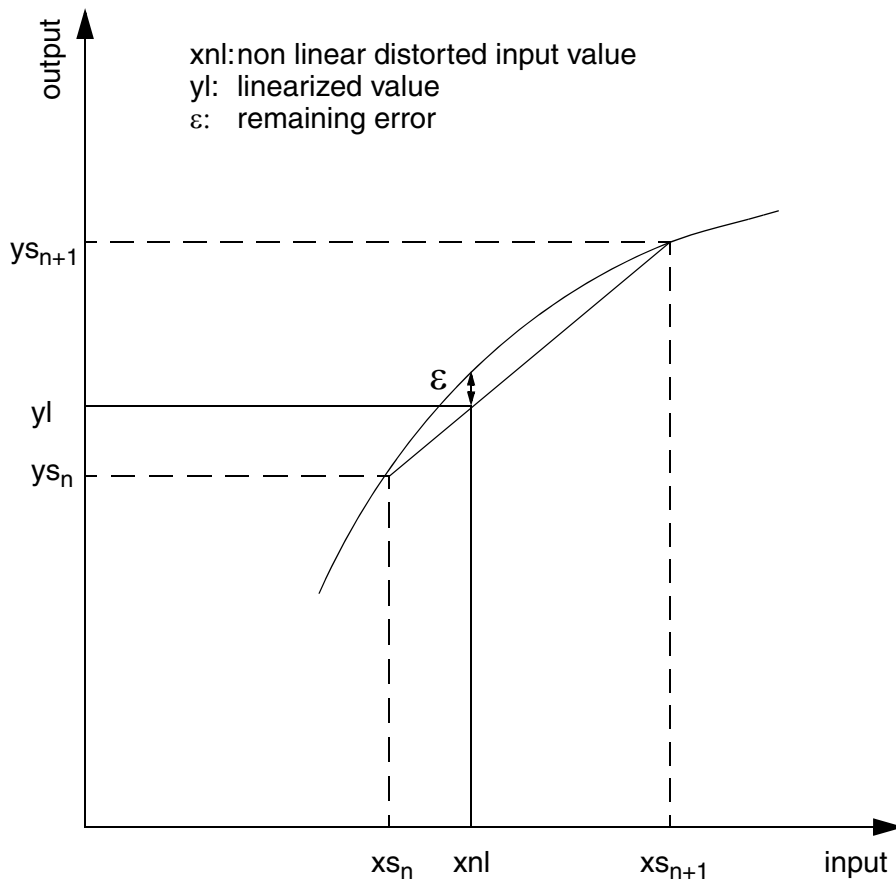

Fig. 3–9: Linearization - detail

The constraint of the linearization is that the input characteristic has to be a monotonic function. In addition, it is recommended that the input does not have a saddle point or inflection point, i.e. regions where the input is nearly constant. This would require a high density of set points.

To do a linearization the following steps are necessary:

- Measure output characteristics over full range
- Find the inverse (Point-wise mirroring the graph on the bisectrix)
- Do a spline fit on the inverse
- Insert digital value of set point position into spline fit function for each set point (0, 1024, 2048, ..., 32768)
- Resulting values can be directly entered into the EEPROM

3.5. Functional Safety

3.5.1. Function Safety Manual and Functional Safety Report

The Functional Safety Manual for HAC 37xy contains the necessary information to support customers to realize a safety compliant application by integrating HAC 37xy as an ASIL B ready component, in their system. The Functional Safety Manual can be provided upon request.

The Functional Safety Analysis Report describes the assumed Safety Goal, the corresponding Failure Modes as well as the Base Failure Rate for die and package according to IEC TR 62380. It can be provided based on a TDK-Micronas mission profile as well as customer mission profiles.

3.5.2. Integrated Diagnostic Mechanism

The HAC 37xy features two groups of diagnostic functions. The first group contains basic functions that are always active. The second group can be activated by the customer and contains supervision and self-tests related to the signal path and sensor memory.

Diagnostic features that are always active:

- Wire break detection for supply and ground line
- Undervoltage detection
- Thermal supervision of output stage (overcurrent, short circuit, etc.)

Diagnostic features that can be activated by customer:

- Continuous internal supply voltage monitoring
- A/D converter stuck error
- Output signal clamping
- A/D converter clipping
- Continuous state machine self-test
- Continuous EEPROM self-test
- Continuous ROM parity check
- Temperature sensor error
- Magnetic range detection
- Overvoltage detection

In case of HAC 3715 and HAC 372x, the sensor indicates a fault immediately by switching the output signal to the selected error band in case that the diagnostic mode is activated by the customer (CUST_SETUP1, bit 1). The customer can select if the output goes to the upper or lower error band by setting bit number 7 in the CUST_SETUP1 register (Table 3–3 on page 25). An output short drives the output to VSUP, GND or tristate depending of the customer settings. Further details can be found in Section 4.9. on page 47.

The sensor switches the output to tristate if an over temperature condition is detected by the thermal supervision. The sensor switches the output to ground in case of a VSUP wire-break and to VSUP in case of a GND wire-break.

HAC 373x and HAC 3711 indicate a failure by changing the PWM frequency from the nominal value. The different errors are then coded in different duty-cycles.

Table 3–5: Failure indication for HAC 3711 and HAC 373x in PWM mode

Failure Mode	Frequency	Duty-Cycle
EEPROM, ROM, A/D converter stuck error, state machine self-test and the internal supply voltage monitor	50%	95%
Magnetic field too low	50%	62.5%
Magnetic field too high	50%	55%
VSUP Overvoltage (CUST_SETUP1, bit 7 = 0)	50%	75%
VSUP Overvoltage (CUST_SETUP1, bit 7 = 1)	Output driven to low output state	
Temperature error	50%	85%
Undervoltage	No PWM	n.a.
A/D converter clipping	50%	70%

In case of undervoltage, the sensors will go into reset and the output will be actively driven to low output state.

Note In case of an error the sensors change the selected PWM frequency.
Example: During normal operation the PWM frequency is 1 kHz, in case of an error 500 Hz.

HAC 373x and HAC 3711 are transmitting detailed error codes in case of selected SENT output. Further details can be found in Section 3.6. on page 31.

3.6. SENT Output Protocol

HAC 373x and HAC 3711 comply with the SAEJ2716 standard rev. 4 and support the following three frame formats:

- Two 12-bit Fast Channels (3 nibble position information and 3 nibble temperature information or magnetic-field amplitude)
- One 12-bit Fast Channel (3 nibble position information)
- Secure Single Sensors with 12-bit Fast Channel (3 nibble position information) and 12-bit Secure Sensor Information

All different modes are customer selectable via EEPROM bits (see Table 3–4 on page 26).

In SENT output mode the unidirectional communication from the sensor to a receiver module (e.g. an Electronic Control Unit) occurs independently of any action of the receiver module. It does not require any synchronization signal from the receiver module and does not include a coordination signal from the controller/receiving devices.

3.6.1. 6 Data Nibble Frame with Two Fast Channels (H.1 Format SAEJ2716 rev. 4)

In this SENT mode the sensor transmits SENT frames with 6 data nibbles. 3 data nibbles with 12-bit position information and 3 data nibbles with 12-bit temperature information or 12-bit magnetic-field amplitude information (customer configurable). They are formatted according to Table 3–6.

Table 3–6: Nibble description for 6 data nibble frame format with two fast channels

Pulse		Remarks
#	Description	
1	Synchronization/ Calibration	It is mandatory to measure the synchronization / calibration period for calibration of the clock tick time t_{tick} at the ECU
2	4-bit Status & Communication Nibble	Status [0]: 1, if CUST_SETUP1-bit 4 = 1 & error; otherwise 0 Status [1]: 1, if CUST_SETUP1-bit 4 = 1 & temp. error; otherwise 0 Status [2...3]: Enhanced Serial Message (see Section 3.6.8. on page 36)
3	4-bit Data Nibble MSN 1	Position Value [11:8]
4	4-bit Data Nibble MidN 1	Position Value [7:4]
5	4-bit Data Nibble LSN 1	Position Value [3:0]
6	4-bit Data Nibble LSN 2	Chip Temperature Value [3:0] or Magnetic Amplitude Value [3:0]
7	4-bit Data Nibble MidN 2	Chip Temperature Value [7:4] or Magnetic Amplitude Value [7:4]
8	4-bit Data Nibble MSN 2	Chip Temperature Value [11:8] or Magnetic Amplitude Value [11:8]
9	4-bit CRC Nibble	Enhanced CRC see SAEJ2716
10	Pause Pulse	Optional. Customer configurable.

3.6.2. 3 Data Nibble Frame with One Fast Channel (H.2 Format SAEJ2716 rev. 4)

In this SENT mode the sensor transmits SENT frames with 3 data nibbles containing 12-bit position information. They are formatted according to Table 3–7.

Table 3–7: Nibble description for 3 data nibble frame format with one fast channel

Pulse		Remarks
#	Description	
1	Synchronization/ Calibration	It is mandatory to measure the synchronization / calibration period for calibration of the clock tick time t_{tick} at the ECU
2	4-bit Status & Communication Nibble	Status [0]: 1, if CUST_SETUP1-bit 4 = 1 & error; otherwise 0 Status [1]: 0 Status [2...3]: Enhanced Serial Message (see Section 3.6.8. on page 36)
3	4-bit Data Nibble MSN 1	Position Value [11:8]
4	4-bit Data Nibble MidN 1	Position Value [7:4]
5	4-bit Data Nibble LSN 1	Position Value [3:0]
6	4-bit CRC Nibble	Enhanced CRC see SAEJ2716
7	Pause Pulse	Optional. Customer configurable.

3.6.3. 6 Data Nibble Frame with Secure Information (H.4 Format SAEJ2716 rev. 4)

In this SENT mode the sensor transmits SENT frames with 3 data nibbles containing 12-bit position information as well as 3 data nibbles containing 12-bit secure sensor information. The secure sensor information consists of an 8-bit rolling counter and the inverted copy of the MSN of the transmitted position information. They are formatted according to Table 3–8.

Table 3–8: Nibble description for 6 data nibble frame format with secure information

Pulse		Remarks
#	Description	
1	Synchronization/ Calibration	It is mandatory to measure the synchronization / calibration period for calibration of the clock tick time t_{tick} at the ECU
2	4-bit Status & Communication Nibble	Status [0]: 1, if CUST_SETUP1-bit 4 = 1 & error; otherwise 0 Status [1]: 0 Status [2...3]: Enhanced Serial Message (see Section 3.6.8. on page 36)
3	4-bit Data Nibble MSN 1	Position Value [11:8]
4	4-bit Data Nibble MidN 1	Position Value [7:4]
5	4-bit Data Nibble LSN 1	Position Value [3:0]
6	4-bit Data Nibble MSN 2	Rolling Counter MSN
7	4-bit Data Nibble MidN 2	Rolling Counter LSN
8	4-bit Data Nibble LSN 2	Inverted Copy of Data Nibble MSN 1
9	4-bit CRC Nibble	Enhanced CRC see SAEJ2716
10	Pause Pulse	Optional. Customer configurable.

3.6.4. Error Diagnostic Reporting on Fast Channel

The Status bits are set to one in case of “sensor error indication” or “sensor functionality and processing error indication” as long as bit 4 in CUST_SETUP1 is set to one.

If bit 4 is set to zero Status bits are always zero.

In addition the diagnostic can be reported through the 12-bit payload of channel 1 and/or channel 2. Below table shows the values that will be sent in case of an internal error.

Table 3–9: Error codes transmitted on fast channel 1 and/or 2

Error	Code	
	CH 1	CH 2
Sensor error indication	4091	N/A
Sensor functionality and processing error indication	4090	4090
Data Clamping: High	4088	4088
Data Clamping: Low	1	1

Note CH 2 is only showing error code 4090 in case of a temperature error. All other errors will be indicated on CH 1 only.

The transmission of error codes on fast channel 1 and/or 2 can be deactivated by a customer EEPROM bit (bit 1 of Customer Setup Register 1, Table 3–3 on page 25). The sensor will then continue to transmit measurement data, but Status Error will be still set to 1.

3.6.4.1. Impact of Diagnosis Bit (CUST_SETUP1 - Bit 1) on SENT Output

The following table describes the impact of the Diagnosis bit on the error indication in SENT mode depending on the Pause Pulse configuration. Table 3–10 shows the behavior for the H.2 and H.4 format. Table describes the behavior in case of the H.1 format.

Table 3–10: Error indication in H.2 and H.4 format

DIAGNOSIS bit	Effect on	Pause Pulse active	No Pause Pulse
0: Enabled	Status [0]	Shows diagnosis error	Shows diagnosis error and double data transmission
	Fast Channel 1	Shows diagnosis error code	Shows diagnosis error code
1: Disabled	Status [0]	Shows diagnosis error	Shows no diagnosis error but double data transmission information
	Fast Channel 1	Shows no diagnosis error code	Shows no diagnosis error code

Table 3–11: Error indication in H.1 format

DIAGNOSIS bit	Effect on	Pause Pulse active	No Pause Pulse
0: Enabled	Status [0]	Shows diagnosis error	Shows diagnosis error and double data transmission
	Fast Channel 1	Shows diagnosis error code	Shows diagnosis error code
	Status [1]	Shows diagnosis error	Shows diagnosis error
	Fast Channel 2	Shows diagnosis error code	Shows diagnosis error code
1: Disabled	Status [0]	Shows diagnosis error	Shows no diagnosis error but double data transmission information
	Fast Channel 1	Shows no diagnosis error code	Shows no diagnosis error code
	Status [1]	Shows diagnosis error	Shows diagnosis error
	Fast Channel 2	Shows no diagnosis error code	Shows no diagnosis error code

Note Table 3–10 and Table 3–11 are only valid if bit 4 of CUST_SETUP1 register is set to one.

3.6.5. Timing of error reporting on fast channel

In worst case it will take two SENT frames to indicate an error on the output. The overall time depends on the selected frame format and tick time.

3.6.6. Pause Pulse

The pause pulse is present at the end of every frame as defined by the SAEJ2716 standard. Alternatively the pause pulse can be deactivated for HAC 373x and HAC 3711 by a bit combination in the configuration memory (see Table 3–4 on page 26). The length of the pause pulse is automatically adjusted by the chip internal SENT block in order to achieve a constant frame period independent from the message content. The length depends on the frame content and the selected SENT message frequency, as well as on the selected tick time (see Table 3–15 on page 39).

It is possible that in case of deactivated pause pulse some samples may be transmitted twice in series due to the fact that the message time can be shorter than the sample time. Status[0] bit will be set to one in case that a sample is transmitted twice.

Please refer to Table 3–17 and Table 3–18 on page 40 showing tick times allowing a sample synchronous transmission.

3.6.7. CRC Implementation

HAC 373x and HAC 3711 support the new recommended CRC implementation defined in SAEJ2716 rev. 4. The old legacy CRC is not supported.

3.6.8. Slow Channel: Enhanced Serial Message

HAC 373x and HAC 3711 transmit the slow message according to the Enhanced Serial Message Format as specified in the SENT standard SAEJ2716 with the following setup:

The configuration bit is always 0, representing 12-bit data and 8-bit message ID.

3.6.9. Slow Channel: Serial Message Sequence

The device is always transmitting the serial message sequence shown in Table 3–12.

Table 3–12: Serial Message Sequence

#	8-bit ID	Item	12-bit Data	Comment
1	0x03	Sensor type	(see Table 3–14 on page 38)	Customer programmable
2	0x29	Micronas SN	8-bit MSB MIC_ID1	MSB Micronas Serial Number register 1. Right aligned
3	0x2A	Micronas SN	8-bit LSB MIC_ID1	LSB Micronas Serial Number register 1. Right aligned
4	0x01	Error Codes	(see Table 3–13 on page 37)	
5	0x2B	Micronas SN	8-bit MSB MIC_ID2	MSB Micronas Serial Number register 2. Right aligned
6	0x2C	Micronas SN	8-bit LSB MIC_ID2	LSB Micronas Serial Number register 2. Right aligned
7	0x05	Manufacturer Code	0x007	Micronas Manufacturer Code
8	0x01	Error Codes	(see Table 3–13 on page 37)	
9	0x06	Protocol revision	0x004	SAEJ2716 rev. 4
10	0x23	Temperature	1 ... 4088: Temperature Data 4090: Temperature Error	12-bit internal reference temperature. Transfer function Micronas specific.
11	0x1C	Field strength	1 ... 4088: Calculated magnetic-field amplitude	Transfer characteristic is not transmitted
12	0x01	Error Codes	(see Table 3–13 on page 37)	

3.6.10. Slow Channel: Serial Message Error Codes

Diagnostic status codes are transmitted via the serial message. The 8-bit message ID for the diagnostic status code is 01h. The 12-bit code within the 12-bit message can be defined by the device manufacturer in the range between 800h to FFFh. HAC 373x and HAC 3711 feature the error codes described in Table 3–13.

Table 3–13: Serial Message Error Codes

Bit Position	Error Type
0	Memory error
1	Signal path error
2	Voltage regulator error
3	Magnetic-field amplitude out of range error
4	Temperature sensor value not valid
5	Signal path over/underflow error
6	Over voltage error
7:10	Always 0
11	Always 1

Note Diagnostic latch bit (bit[2]) in Customer Setup Register 1 (see Table 3–3 on page 25) must be set to one to ensure stable transmission of error codes. Especially for momentary errors.

3.6.11. Slow Channel: Sensor Types

HAC 373x and HAC 3711 can transmit the sensor type information via the slow channel. The sensor type depends on the final customer application and is therefore customer programmable (Customer Setup Register 2, bit 14 and 13). Table 3–14 shows the transmitted 12-bit value depending on the selected frame format and sensor function.

Table 3–14: Selectable Sensor Types

Bit combination	12-bit Value	Description
00	0x050	Not specified
Format: 6 data nibble with two fast channels		
01	0x056	Linear position
10	0x065	Angle position
11	0x075	Relative position
Format: 3 data nibble with one fast channel		
01	0x051	Linear position
10	0x060	Angle position
11	0x070	Relative position
Format: 6 data nibble with secure information		
01	0x055	Linear position
10	0x064	Angle position
11	0x074	Relative position

3.6.12. Start-Up behavior

The start-up behavior is customer configurable. The device can either transmit zero messages until a valid information is available (SAEJ2716 conform). Alternatively the device transmits 4094 until a valid information is available. The start-up behavior is customer configurable by bit 4 in the CUST_SETUP1 register.

3.6.13. Message Time for SENT Frames with Pause Pulse

The SENT frame repetition frequency (SENTF) is defined by the position sampling frequency. The selectable SENT frame repetition frequency is limited by the configured tick time, the transmitted data value and the minimum and maximum pause pulse duration.

The tick time is customer programmable and can be selected between 0.5 μs and 4.25 μs in steps of 0.25 μs . The tick time is defined by bits 11 to 8 in the Customer Setup Register 2 (see Table 3–4 on page 26).

The pulse low time is fixed to 5 ticks. The minimum pause pulse duration is 12 ticks.

The delivery of new position values is synchronous with the SENT messages, i.e. one SENT message is transmitted per position sample. Thus, the propagation delay is very low and the message time is nearly constant.

Table 3–15 and Table 3–16 show the recommended sample frequencies for certain tick times to ensure samples synchronous transmission.

Table 3–15: Recommended tick time settings for 6 data nibble transmission

t_{tick}^1 [μs]	0.50	0.75	1.00	1.25	1.50	1.75	2.00	2.25	2.50	2.75	3.00	3.25	3.50	3.75	4.00	4.25
TICK [LSB]	0	1	2	3	4	5	6	7	8	9	10	11	12	13	14	15
SENTF [Hz]																
4000	NC	NC	–	–	–	–	–	–	–	–	–	–	–	–	–	–
2660	NC	NC	NC	NC	–	–	–	–	–	–	–	–	–	–	–	–
2000	NC	NC	NC	NC	NC	NC	–	–	–	–	–	–	–	–	–	–
1600	NC	NC	NC	NC	NC	NC	NC	NC	–	–	–	–	–	–	–	–
1000	NC	NC	NC	NC	NC	NC	NC	NC	NC	SC	SC	SC	SC	–	–	–
800	NC	NC	NC	NC	NC	NC	NC	NC	NC	SC	SC	SC	SC	SC	SC	SC
500	NC	NC	NC	NC	NC	NC	NC	NC	NC	SC	SC	SC	SC	SC	SC	SC

¹⁾ Clock tolerance of +/- 10% is not included
 NC: None SAEJ2716 conform settings
 SC: SAEJ2716 specification conform settings

Table 3–16: Recommended tick time settings for 3 data nibble transmission

$t_{\text{tick}}^{1)}$ [μs]	0.50	0.75	1.00	1.25	1.50	1.75	2.00	2.25	2.50	2.75	3.00	3.25	3.50	3.75	4.00	4.25
TICK [LSB]	0	1	2	3	4	5	6	7	8	9	10	11	12	13	14	15
SENTF [Hz]																
8000	NC	–	–	–	–	–	–	–	–	–	–	–	–	–	–	–
4000	NC	NC	NC	NC	–	–	–	–	–	–	–	–	–	–	–	–
2660	NC	NC	NC	NC	NC	NC	–	–	–	–	–	–	–	–	–	–
2000	NC	NC	NC	NC	NC	NC	NC	NC	NC	–	–	–	–	–	–	–
1600	NC	NC	NC	NC	NC	NC	NC	NC	NC	SC	SC	–	–	–	–	–
1000	NC	NC	NC	NC	NC	NC	NC	NC	NC	SC	SC	SC	SC	SC	SC	SC
800	NC	NC	NC	NC	NC	NC	NC	NC	NC	SC	SC	SC	SC	SC	SC	SC
500	NC	NC	NC	NC	NC	NC	NC	NC	NC	SC	SC	SC	SC	SC	SC	SC

1) Clock tolerance of +/- 10% is not included
 NC: None SAEJ2716 conform settings
 SC: SAEJ2716 specification conform settings

Table 3–17 and Table 3–18 show allowed settings leading to sample synchronous transmission in case of deactivated pause pulse.

Table 3–17: Recommended tick time settings for 6 data nibble transmission for sample accurate transmission

$t_{\text{tick}}^{1)}$ [μs]	0.50	0.75	1.00	1.25	1.50	1.75	2.00	2.25	2.50	2.75	3.00	3.25	3.50	3.75	4.00	4.25
TICK [LSB]	0	1	2	3	4	5	6	7	8	9	10	11	12	13	14	15
	DT	DT	ST	ST	ST	ST	ST	ST	ST	ST	ST	ST	ST	ST	ST	ST

1) Clock tolerance of +/- 10% is not included
 DT: Double transmission of measurement values possible and indicated in Status[0]
 ST: Sample synchronous transmission of measurement values

Table 3–18: Recommended tick time settings for 3 data nibble transmission for sample accurate transmission

$t_{\text{tick}}^{1)}$ [μs]	0.50	0.75	1.00	1.25	1.50	1.75	2.00	2.25	2.50	2.75	3.00	3.25	3.50	3.75	4.00	4.25
TICK [LSB]	0	1	2	3	4	5	6	7	8	9	10	11	12	13	14	15
	DT	DT	DT	ST	ST	ST	ST	ST	ST	ST	ST	ST	ST	ST	ST	ST

1) Clock tolerance of +/- 10% is not included
 DT: Double transmission of measurement values possible and indicated in Status[0]
 ST: Sample synchronous transmission of measurement values

4. Specifications

4.1. Outline Dimensions

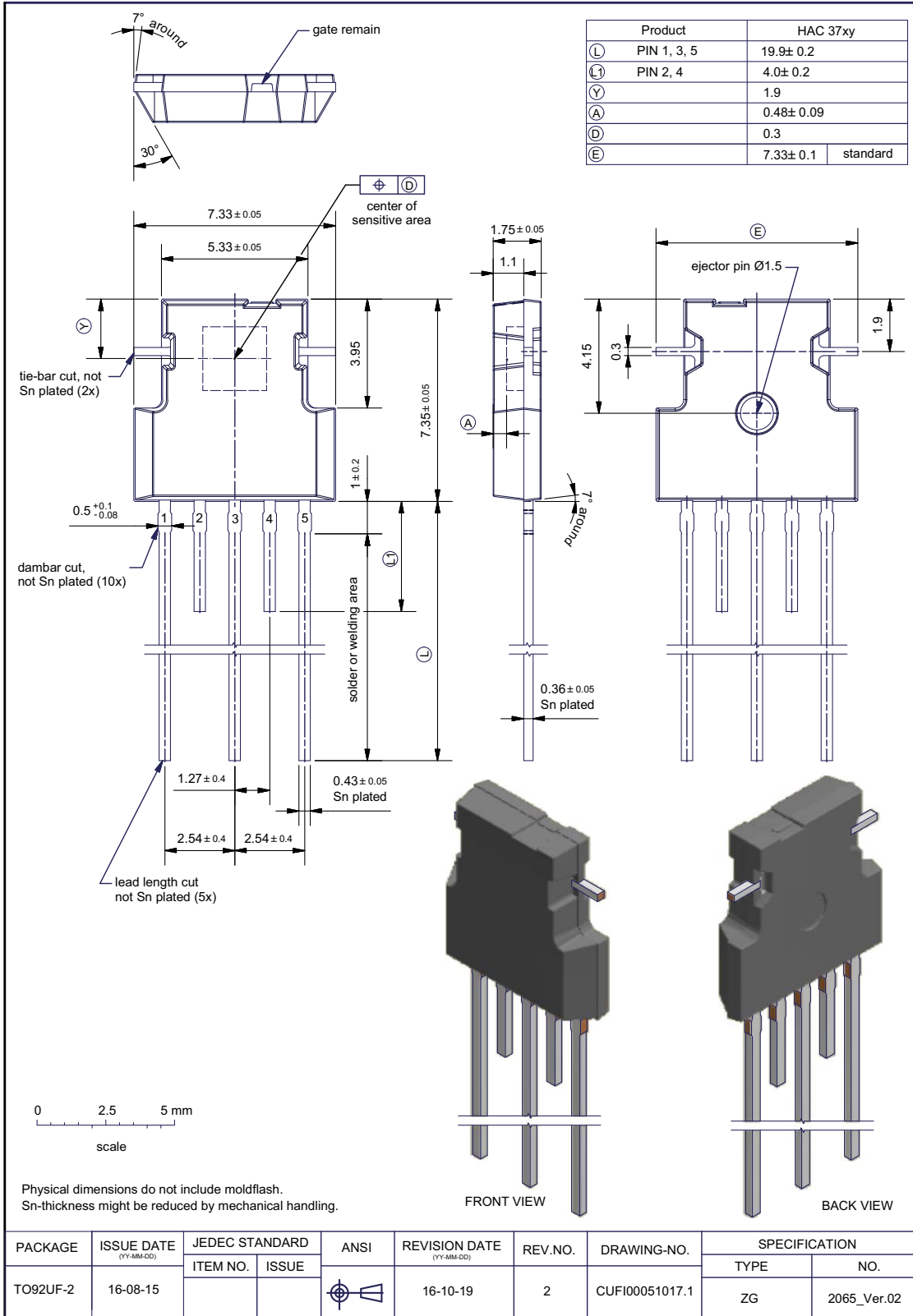

Physical dimensions do not include moldflash.
Sn-thickness might be reduced by mechanical handling.

PACKAGE	ISSUE DATE (YY-MM-DD)	JEDEC STANDARD		ANSI	REVISION DATE (YY-MM-DD)	REV.NO.	DRAWING-NO.	SPECIFICATION	
		ITEM NO.	ISSUE					TYPE	NO.
TO92UF-2	16-08-15				16-10-19	2	CUFI00051017.1	ZG	2065_Ver.02

© Copyright 2016 TDK-Micronas GmbH, all rights reserved

Fig. 4-1:
TO92UF-2: Plastic Transistor Standard UF package, 3 leads, non-spread
Weight approximately 0.3 g

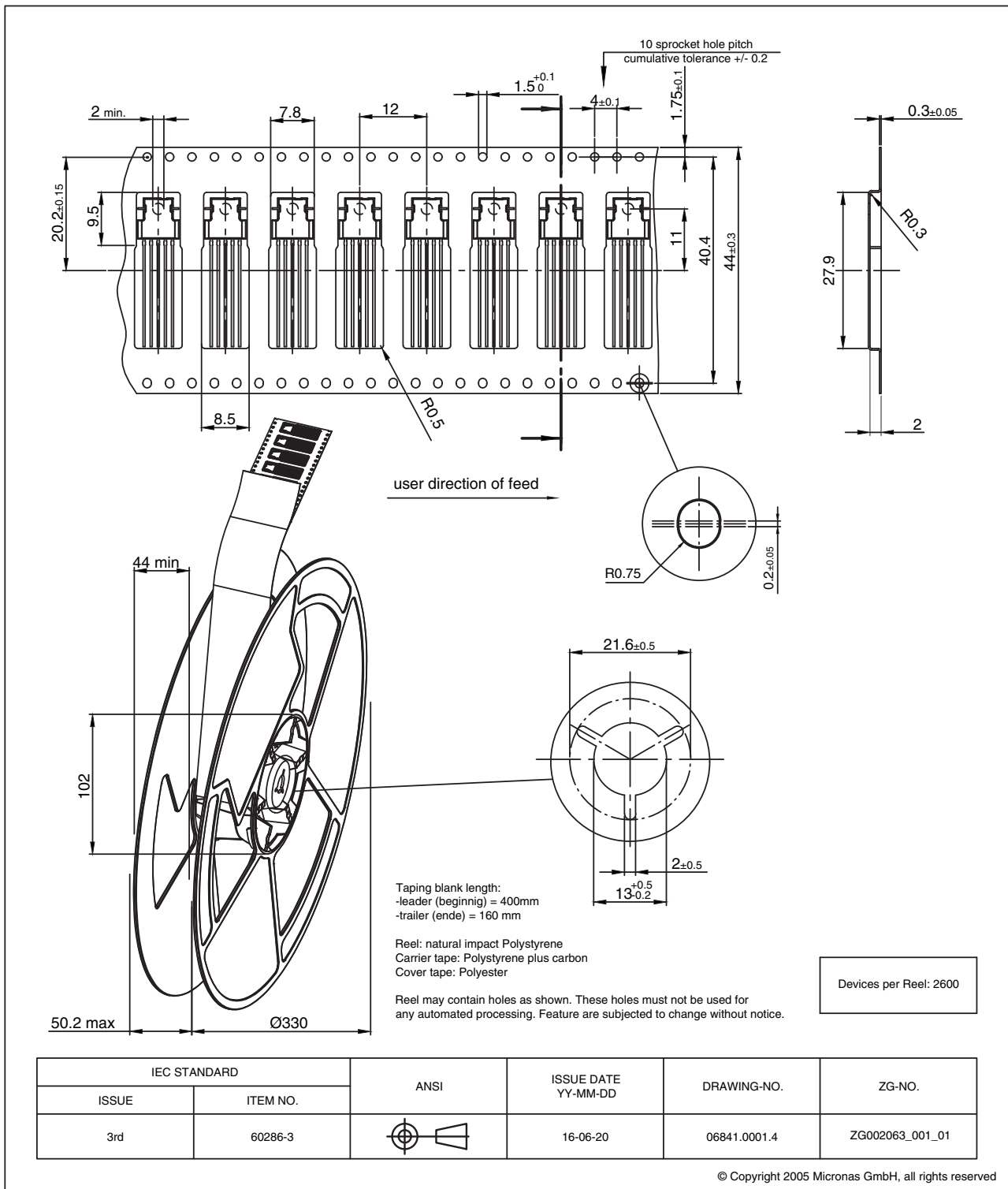

Fig. 4-2:
TO92UF: Tape and Reel Finishing

4.2. Soldering, Welding, Assembly

Information related to solderability, welding, assembly, and second-level packaging is included in the document “Guidelines for the Assembly of Micronas Packages”.

It is available on the TDK-Micronas website (<http://www.micronas.com/en/service-center/downloads>) or on the service portal (<http://service.micronas.com>).

4.3. Storage and Shelf Life package

Information related to storage conditions of Micronas sensors is included in the document “Guidelines for the Assembly of Micronas Packages”. It gives recommendations linked to moisture sensitivity level and long-term storage.

It is available on the TDK-Micronas website (<http://www.micronas.com/en/service-center/downloads>) or on the service portal (<http://service.micronas.com>).

4.4. Size of Sensitive Area

275 μm x 275 μm

4.5. Definition of Magnetic-Field Vectors

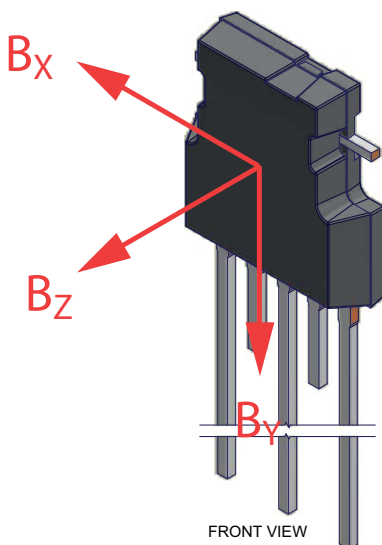

4.6. Pin Connections and Short Description

Pin No.	Pin Name	Type	Short Description
1	VSUP	SUPPLY	Supply Voltage
2	TEST1	IN	Test
3	GND	GND	Ground
4	TEST2	I/O	Test
5	OUT	I/O	Output and Programming

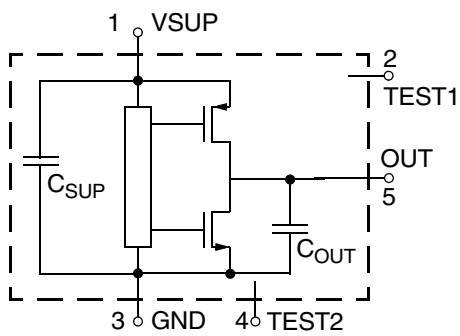

Fig. 4–3: Pin configuration

4.7. Absolute Maximum Ratings

Stresses beyond those listed in the “Absolute Maximum Ratings” may cause permanent damage to the device. This is a stress rating only. Functional operation of the device at these conditions is not implied. Exposure to absolute maximum rating conditions for extended periods will affect device reliability.

This device contains circuitry to protect the inputs and outputs against damage due to high static voltages or electric fields; however, it is advised that normal precautions must be taken to avoid application of any voltage higher than absolute maximum-rated voltages to this high-impedance circuit.

All voltages listed are referenced to ground (GND).

Symbol	Parameter	Pin Name	Min.	Max.	Unit	Condition
V_{SUP}	Supply Voltage	VSUP	-20	20	V	$t < 1 \text{ hr}^3$)
V_{OUT}	Output Voltage	OUT	-6	20	V	$t < 1 \text{ hr}^3$)
$V_{OUT} - V_{SUP}$	Excess of Output Voltage over Supply Voltage	OUT, VSUP	-	2	V	
I_{OUT}	Continuous Output Current	OUT	-10	10	mA	
B_{max}	Magnetic Field	-1	-	1	T	
T_A	Ambient Temperature	-	-40	160	°C	4)
$T_{storage}$	Transportation/Short Term Storage Temperature	-	-55	150	°C	Device only without packing material
V_{ESD}	ESD Protection	VSUP, GND, OUT	-8	8	kV	1)
		VSUP, GND, OUT	-8	8	kV	HAC3715 and HAC372x ²⁾
		VSUP, GND, OUT	-6	6	kV	HAC3711 and HAC373x ²⁾
		TEST1, TEST2	-2	2	kV	1)
1) AEC-Q100-002 (100 pF and 1.5 k Ω) 2) Unpowered Gun test (150 pF/330 Ω or 330 pF/2 k Ω) according to ISO 10605-2008 3) No cumulated stress 4) Consider current consumption, mounting condition (e.g. overmold, potting) and mounting situation for T_A in relation to T_J						

4.8. Recommended Operating Conditions

Functional operation of the device beyond those indicated in the “Recommended Operating Conditions/Characteristics” is not implied and may result in unpredictable behavior, reduced reliability and lifetime of the device.

All voltages listed are referenced to ground (GND).

Symbol	Parameter	Pin Name	Min.	Typ.	Max.	Unit	Condition
V _{SUP}	Supply Voltage	VSUP	4.5 5.7	5 6.0	5.5 6.5	V	Normal Operation During Programming
I _{OUT}	Continuous Output Current	OUT	-1.2 -	- -	1.2 5.5	mA mA	HAC3715 and HAC372x HAC3711 and HAC373x
R _L	Load Resistor	OUT	5	10	-	kΩ	HAC3715 and HAC372x pull-up & pull-down resistor
			1	-	-	kΩ	HAC3711 and HAC373x pull-up resistor
N _{PRG}	Number of Memory Programming Cycles	-	-	-	100	cycles	0 °C < T _{amb} < 55 °C
B _{AMP}	Recommended Magnetic-Field Amplitude	-	±20	-	±100	mT	
T _J	Junction Temperature ¹⁾	-	-40	-	170	°C	for 1000 hrs
T _A	Ambient Temperature ²⁾	-	-40	-	150	°C	
¹⁾ Depends on the temperature profile of the application. Please contact TDK-Micronas for life time calculations. ²⁾ Consider current consumption, mounting condition (e.g. overmold, potting) and mounting situation for T _A in relation to T _J							

Note

It is possible to operate the sensor with magnetic fields down to ±5 mT. For magnetic fields below ±20 mT the sensor performance will be reduced.

4.9. Characteristics

at $T_A = -40\text{ °C}$ to 150 °C , $V_{SUP} = 4.5\text{ V}$ to 5.5 V , $GND = 0\text{ V}$, after programming and locking of the sensor, at Recommended Operation Conditions if not otherwise specified in the column “Conditions”.

Typical Characteristics for $T_J = 25\text{ °C}$ and $V_{SUP} = 5\text{ V}$.

Symbol	Parameter	Pin Name	Limit Values			Unit	Test Conditions
			Min.	Typ.	Max.		
I_{SUP}	Supply Current over Temperature Range	VSUP	–	8	12	mA	
	Resolution ¹⁾	OUT	–	12	–	bit	for HAC3715/HAC372x ratio-metric to V_{SUP} for HAC3711/HAC373x (depends on PWM Period)
			–	12	–	bit	
$t_{startup}$	Start-up Time ²⁾	OUT	–	1.4	1.8	ms	(see Fig. 4–4 on page 51) LP_FILTER = OFF
Overvoltage and Undervoltage Detection							
$V_{SUP,UV}$	Undervoltage Detection Level	VSUP	3.3 3.1	3.9 3.7	4.3 4.1	V V	Functionality Mode: Normal Functionality Mode: Extended CUST_SETUP1 register bit 5
$V_{SUP,UVhyst}$	Undervoltage Detection Level Hysteresis ²⁾	VSUP	–	200	–	mV	
$V_{SUP,OV}$	Overvoltage Detection Level	VSUP	5.6 8.5	6.2 9.5	6.9 10.4	V V	Functionality Mode: Normal Functionality Mode: Extended CUST_SETUP1 register bit 5
$V_{SUP,OVhyst}$	Overvoltage Detection Level Hysteresis ²⁾	VSUP	–	225	–	mV	
Output Voltage in Case of Error Detection							
$V_{SUP,DIAG}$	Supply Voltage required to get defined Output Voltage Level ²⁾	VSUP	–	2.3	–	V	The output will be ‘low’ for $V_{SUP,DIAG} < V_{SUP} < V_{SUP,UV}$
$V_{Error,Low}$	Output Voltage Range of Lower Error Band ²⁾	OUT	0	–	4	% V_{SUP}	$V_{SUP} > V_{SUP,UV}$ ERROR BAND bit 7=1 in CUST_SETUP1 Analog Output $5\text{ k}\Omega \leq R_L \leq 200\text{ k}\Omega$
$V_{Error,High}$	Output Voltage Range of Upper Error Band ²⁾	OUT	96	–	100	% V_{SUP}	$V_{SUP} > V_{SUP,UV}$ ERROR BAND bit 7=0 in CUST_SETUP1 Analog Output $5\text{ k}\Omega \leq R_L \leq 200\text{ k}\Omega$
¹⁾ Guaranteed by Design ²⁾ Characterized on small sample size, not tested.							

Symbol	Parameter	Pin Name	Limit Values			Unit	Test Conditions
			Min.	Typ.	Max.		
Output Short Detection Parameter							
t_{OCD}	Overcurrent Detection Time ²⁾	OUT	–	96	–	μs	
t_{Timeout}	Time Period without Overcurrent Detection ²⁾	OUT	–	32	–	ms	
I_{OVC}	Detectable Output Short Current ²⁾	OUT	–	10	–	mA	
HAC3715 and HAC372x (Analog Output)							
t_{OSD}	Overall Signal Delay ¹⁾	OUT	–	0.312	0.343	ms	Overall signal delay between sensor front-end and output For 8 kHz sample frequency Interpolator deactivated
DNL	Differential Non-Linearity of D/A converter	OUT	–3	0	3	LSB	
E_{R}	Ratiometric Error of Output over temperature (Error in $V_{\text{OUT}}/V_{\text{SUP}}$)	OUT	–0.12	0	0.12	%	Max of [$V_{\text{OUT}5} - V_{\text{OUT}4.5}$ and $V_{\text{OUT}5.5} - V_{\text{OUT}5}$] at $V_{\text{OUT}} = 10\%$ and $90\% V_{\text{SUP}}$
INL	Integral Non-Linearity of D/A converter	OUT	–0.1	0	0.1	%	% of supply voltage
ΔV_{OFFSET}	D/A converter offset drift over temperature range related to $25\text{ }^{\circ}\text{C}$ ²⁾	OUT	–0.2	0	0.2	$\%V_{\text{SUP}}$	
V_{OUTH}	Output High Voltage ³⁾	OUT	93	–	–	$\%V_{\text{SUP}}$	R_{L} Pull-up/-down = 5 k Ω
V_{OUTL}	Output Low Voltage ³⁾	OUT	–	–	7	$\%V_{\text{SUP}}$	R_{L} Pull-up/-down = 5 k Ω
ΔV_{OUTCL}	Accuracy of Output Voltage at Clamping Low Voltage over Temperature Range ²⁾	OUT	–30	0	30	mV	$V_{\text{SUP}} = 5\text{ V}$ R_{L} Pull-up/-down = 5 k Ω
ΔV_{OUTCH}	Accuracy of Output Voltage at Clamping High Voltage over Temperature Range ²⁾	OUT	–30	0	30	mV	
$\text{OUT}_{\text{Noise}}$	Output Noise RMS ²⁾	OUT	–	1.0	4	mV	Min. magnetic ampl. = $\pm 20\text{ mT}$ $f_{\text{C}} = 22\text{ kHz}$. No DNC or low-pass filter active
R_{OUT}	Output Resistance	OUT	–	1	10	Ω	$V_{\text{OUTLmax}} \leq V_{\text{OUT}} \leq V_{\text{OUTHmin}}$
¹⁾ Guaranteed by Design ²⁾ Characterized on small sample size, not tested. ³⁾ Signal band area with full accuracy is located between V_{OUTL} and V_{OUTH} . Reduced accuracy below V_{OUTL} and above V_{OUTH} .							

Symbol	Parameter	Pin Name	Limit Values			Unit	Test Conditions
			Min.	Typ.	Max.		
Open-Circuit Detection							
V _{OUT}	Output voltage at open V _{SUP} line	OUT	0	0.1	0.15	V	V _{SUP} = 5 V R _L ⁴⁾ = 10 kΩ to 200 kΩ
			0	0.1	0.2	V	V _{SUP} = 5 V 5 kΩ ≤ R _L ⁴⁾ < 10 kΩ
V _{OUT}	Output voltage at open GND line	OUT	4.85	4.9	5.0	V	V _{SUP} = 5 V R _L ⁴⁾ = 10 kΩ to 200 kΩ
			4.8	4.9	5.0	V	V _{SUP} = 5 V 5 kΩ ≤ R _L ⁴⁾ < 10 kΩ
HAC3711 and HAC373x (Digital Output: Push-Pull Configuration)							
V _{OUTH}	Output High Voltage	OUT	4.8	4.9	–	V	V _{SUP} = 5 V, R _{LPull-up/down} = 5 kΩ
V _{OUTL}	Output Low Voltage	OUT	–	0.1	0.2	V	V _{SUP} = 5 V, R _{LPull-up/down} = 5 kΩ
V _{OUTL}	Output Low Voltage ²⁾	OUT	–	0.4	0.65	V	V _{SUP} = 5 V, R _{LPull-up} = 1 kΩ
t _{rise}	Rise Time of Digital Output ²⁾	OUT	–	0.2	0.5	μs	V _{SUP} = 5 V, R _{LPull-up} = 1 kΩ
t _{fall}	Fall Time of Digital Output ²⁾	OUT	–	0.25	0.5	μs	V _{SUP} = 5 V, R _{LPull-up} = 1 kΩ
ROUT_DIG	On Resistance of Digital Push-Pull Driver	OUT	–	100	200	Ω	
HAC3711 and HAC373x (Digital Output: Open-Drain Configuration)							
I _{OH}	Output Leakage Current	OUT	–50	10	500	μA	
V _{OL}	Output Low Voltage ²⁾	OUT	–	0.1	0.2	V	V _{SUP} = 5 V, R _{LPull-up} = 5 kΩ
			–	0.4	0.65	V	V _{SUP} = 5 V, R _{LPull-up} = 1 kΩ ²⁾
t _{rise}	Rise Time of Digital Output ²⁾	OUT	–	4.2	5.3	μs	V _{SUP} = 5 V R _{LPull-up} = 1 kΩ
t _{fall}	Fall Time of Digital Output ²⁾	OUT	–	0.25	0.5	μs	V _{SUP} = 5 V, R _{LPull-up} = 1 kΩ
¹⁾ Guaranteed by Design ²⁾ Characterized on small sample size, not tested. ⁴⁾ RL can be pull-up or pull-down resistor							

Symbol	Parameter	Pin Name	Limit Values			Unit	Test Conditions
			Min.	Typ.	Max.		
PWM Output							
t_{OSD}	Overall Signal Delay ¹⁾	OUT	–	0.312	0.343	ms	Overall signal delay between sensor front-end and output. Transmission time of selected PWM frequency to be added. For 8 kHz sample frequency
OUT_{Noise}	Output Noise RMS ²⁾	OUT	–	0.03	0.08	%	Min. magnetic ampl. = ± 20 mT Related to 100% DC All internal filter off
f_{PWM}	PWM Frequency	OUT	1800 1440 900 720 450 360 225 180	2000 1600 1000 800 500 400 250 200	2200 1760 1100 880 550 440 275 220	Hz	Customer programmable
J_{PWM}	RMS PWM Jitter ²⁾	OUT	–	1	2	LSB ₁₂	$f_{PWM} = 1$ kHz
SENT Output							
$\Delta T_{osc}/T_{osc}$	Clock Accuracy	OUT	–10	0	10	%	On clock tick time without pause pulse
t_{nlow}	Sensor pulse low time	OUT	–	5	–	t_{tick}	
²⁾ Characterized on small sample size, not tested.							
TO92UF Package							
							(Self-heating calculation see Section 5.1. on page 54)
R_{thja}	Thermal Resistance Junction to Air	–	–	–	181	K/W	Determined with a 1s0p board
			–	–	122	K/W	Determined with a 2s2p board
R_{thjc}	Thermal Resistance Junction to Case	–	–	–	30	K/W	Determined with a 1s0p board
			–	–	29	K/W	Determined with a 2s2p board
¹⁾ Guaranteed by Design							
²⁾ Characterized on small sample size, not tested.							

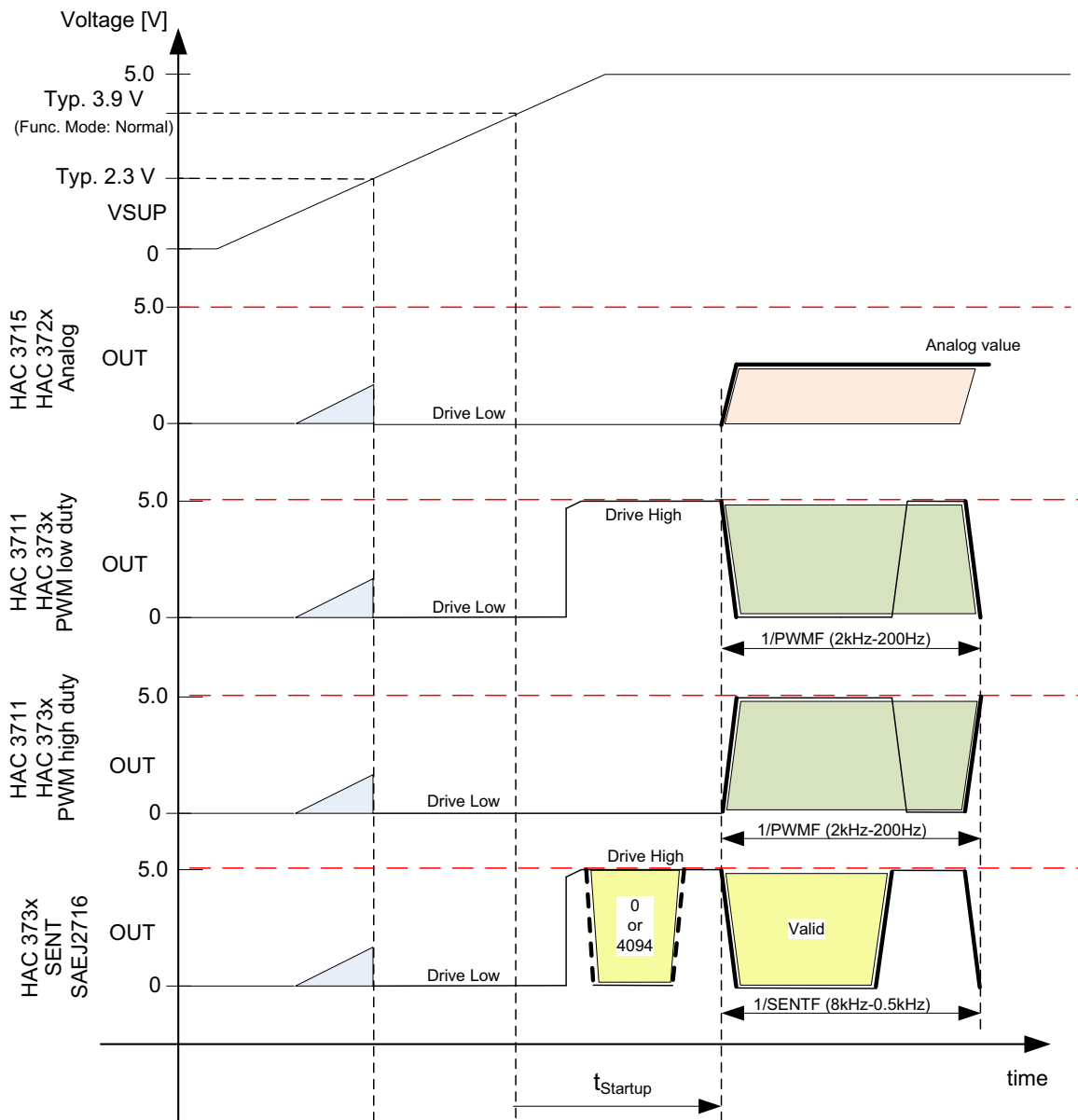

Fig. 4-4: Start-up behavior of HAC37xy in different output modes

4.10. Magnetic Characteristics

at $T_A = -40\text{ °C}$ to 150 °C , $V_{SUP} = 4.5\text{ V}$ to 5.5 V , $GND = 0\text{ V}$, after programming and locking of the sensor, at Recommended Operation Conditions if not otherwise specified in the column "Conditions". Typical Characteristics for $T_J = 25\text{ °C}$ and $V_{SUP} = 5\text{ V}$.

Symbol	Parameter	Pin No.	Min.	Typ.	Max.	Unit	Test Conditions
Θ_{RANGE}	Detectable angle range	OUT	0	–	360	°	
Θ_{res}	Angle resolution	OUT	–	–	0.09	°	(360°/4096)
E_{olinxy}	X/Y angle linearity error over temperature (on output of CORDIC filter)	OUT	–1.2	–	1.2	°	Min. $B_{AMP} = \pm 30\text{ mT}^{1) 2) 4)}$
			–1.7	–	1.7		Min. $B_{AMP} = \pm 20\text{ mT}^{1) 2) 4)}$
ASm_{X/Y_Z}	Absolute sensitivity mismatch on raw signals between X/Y and Z channel	OUT	–3.0	–	3.0	%	$T_J = 25\text{ °C}^{1)}$
$Sense_{XYZ}$	Sensitivity of X/Y and Z Hall Plate	OUT	117	130	143	LSB/ mT	$T_J = 25\text{ °C}^{1)}$
SMm_{X/Y_Z}	Thermal sensitivity mismatch drift of calibrated signals between X/Y and Z channel	OUT	–2.5	–	2.5	%	over full temperature range related to $25\text{ °C}^{1)}$
SMm_{XY}	Thermal sensitivity mismatch drift of calibrated signals between X and Y channel	OUT	–2	–	2	%	over full temperature range related to $25\text{ °C}^{1)}$
$Offset_{XY}$	Offset of calibrated signals of X or Y channel	OUT	–20	–	20	LSB ₁₅	$T_J = 25\text{ °C}^{1)}$ Can be compensated in customer application
$Offset_Z$	Offset of calibrated signal of Z channel	OUT	–20	–	20	LSB ₁₅	$T_J = 25\text{ °C}^{1)}$ Can be compensated in customer application
$\Delta Offset_{XY}$	Offset drift of calibrated signals of X or Y channel	OUT	–70	–	70	LSB ₁₅	over full temperature range related to $25\text{ °C}^{1)}$
$\Delta Offset_Z$	Offset drift of calibrated signals of Z channel	OUT	–20	–	20	LSB ₁₅	over full temperature range related to $25\text{ °C}^{1)}$
E_{opphase}	Magnetic Angle Phase Error ^{1) 3)}	OUT	–	± 0.5	–	°	XY axis
			–	± 1.6	–		XZ axis
			–	± 1.6	–		YZ axis
$\Delta SMm_{XYZlife}$	Relative sensitivity mismatch drift of calibrated signals between X or Y channel and Z channel over life time	OUT	–	1.0	–	%	after 1000h HTOL ¹⁾
$\Delta Offset_{XYlife}$	Offset drift of calibrated signals of X or Y channel over life time	OUT	–	± 30	–	LSB ₁₅	after 1000h HTOL ¹⁾
$\Delta Offset_{Zlife}$	Offset drift of calibrated signal of Z channel over life time	OUT	–	± 15	–	LSB ₁₅	after 1000h HTOL ¹⁾

¹⁾ Characterized on sample base, 3-sigma values, not tested for each device

²⁾ Calculated angular error based on characterization and not on single error summation

³⁾ Can be compensated by setpoint linearization

⁴⁾ After optimal EOL calibration at room temperature

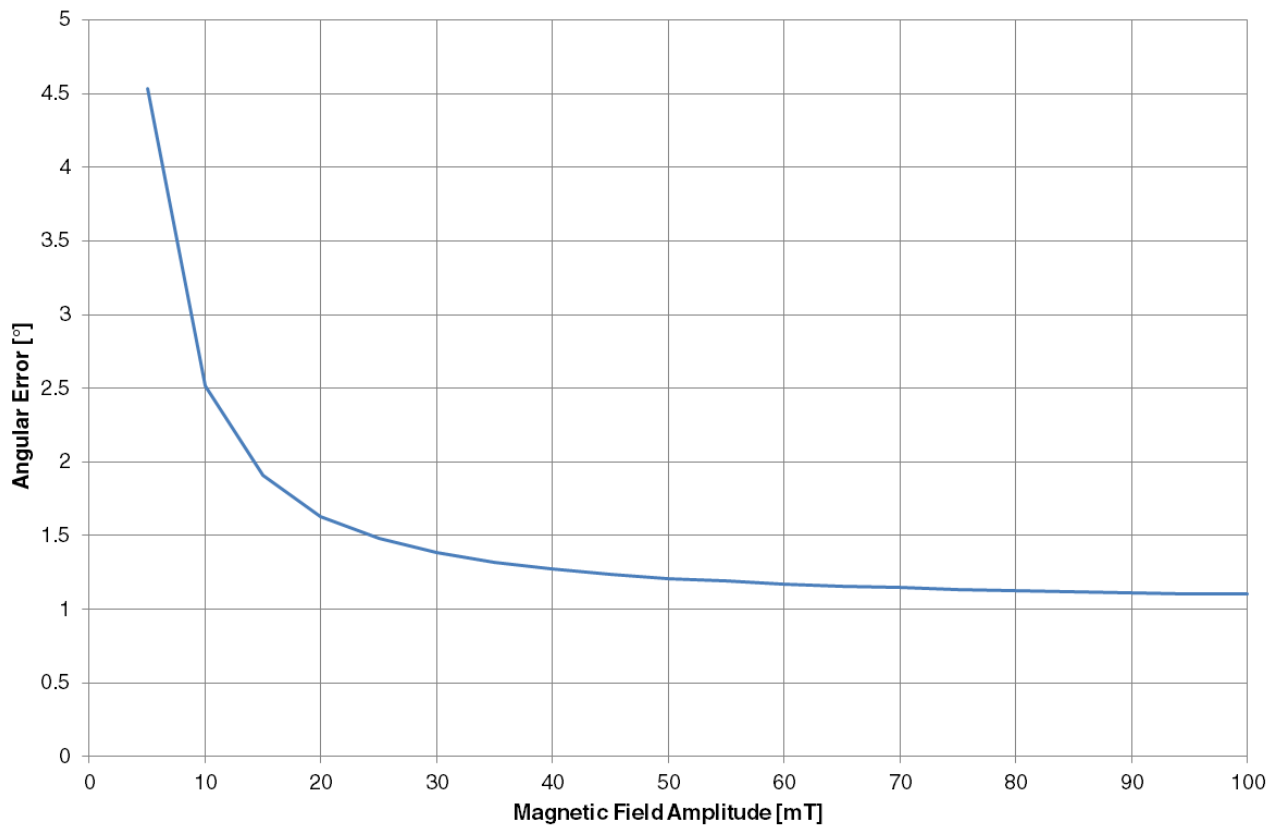

Fig. 4–5: Angular error versus magnetic-field amplitude over full temperature range for devices using X and Y magnetic-field component (for digital output)

5. Application Notes

5.1. Ambient Temperature

Due to the internal power dissipation, the temperature on the silicon chip (junction temperature T_J) is higher than the temperature outside the package (ambient temperature T_A).

$$T_J = T_A + \Delta T$$

At static conditions and continuous operation, the following equation applies:

$$\Delta T = I_{SUP} * V_{SUP} * R_{thjX}$$

The X represents junction to air, case or solder point.

For worst case calculation, use the max. parameters for I_{SUP} and R_{thjX} , and the max. value for V_{SUP} from the application.

Example for calculation of self-heating ΔT

The following example shows the result for junction to air conditions for TO92UF package:

$V_{SUP} = 5.5 \text{ V}$, $R_{thja} = 122 \text{ K/W}$ and $I_{SUP} = 12 \text{ mA}$ the temperature difference $\Delta T = 8 \text{ K}$.

The junction temperature T_J is specified. The maximum ambient temperature T_{Amax} can be calculated as:

$$T_{Amax} = T_{Jmax} - \Delta T$$

Note The calculated self-heating of the device is only valid for the Rth test boards. Depending on the application setup the final results in an application environment might deviate from these values.

5.2. EMC and ESD

Please contact TDK-Micronas for detailed information on EMC and ESD performance.

5.3. Application Circuit for HAC 3715 and HAC 372x

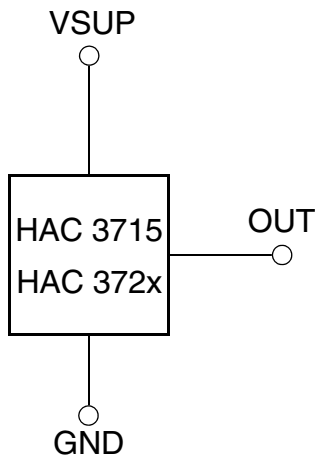

Fig. 5–1: Recommended application circuit for HAC 3715 and HAC 372x

5.4. Application Circuit for HAC 3711 and HAC 373x

PWM Output

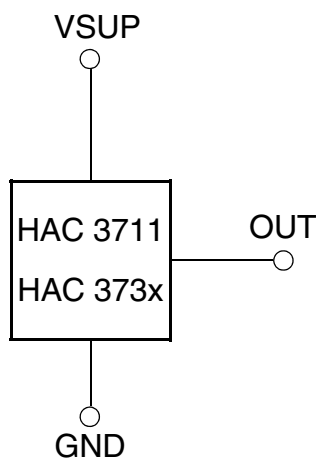

Fig. 5–2: Recommended application circuit for HAC 3711 and HAC 373x in PWM mode

SAEJ2716 SENT Output

In case of SAEJ2716 SENT output mode, it is recommended to add a filter structure at the output pin for having a SENT standard compliant output slew rate.

The following two setups have been tested (with Push-Pull output configuration):

- C01 = 2.2 nF, R01 = 120 Ω
- C01 = 3.3 nF, R01 = 180 Ω

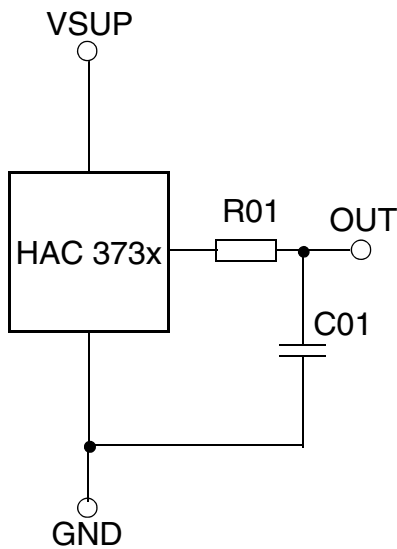

Fig. 5–3: Recommended application circuit for HAC 373x in SENT output mode

5.5. Measurement of a PWM Output Signal of HAC 3711 and HAC 373x

In case of PWM output, the magnetic-field information is coded in the duty cycle of the PWM signal. The duty cycle is defined as the ratio between the high time “s” and the period “d” of the PWM signal (see Fig. 5–4).

Note The PWM signal is either updated with the falling or rising edge depending on the settings of bit 3 in the Customer Setup 2 register.

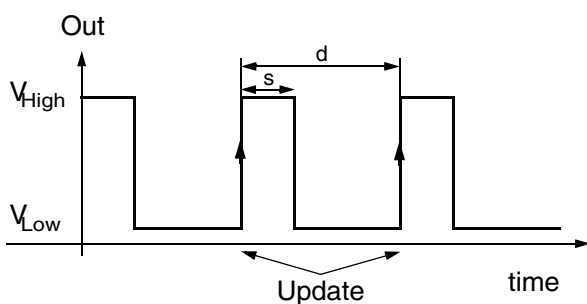

Fig. 5–4: Definition of PWM signal (Bit 3 in customer setup register 2 is set to update with rising edge.)

6. Programming of the Sensor

HAC 37xy features two different customer modes. In **Application Mode** the sensors provide a ratiometric analog output voltage or a digital output signal (PWM or SENT). In **Programming Mode** it is possible to change the register settings of the sensor.

After power-up the sensor is always operating in the **Application Mode**. It is switched to the **Programming Mode** by a pulse at the sensor output pin.

6.1. Programming Interface

In Programming Mode HAC 37xy is addressed by modulating a serial telegram on the sensors output pin. The sensor answers with a modulation of the output voltage.

A logical “0” is coded as no level change within the bit time. A logical “1” is coded as a level change of typically 50% of the bit time. After each bit, a level change occurs (see Fig. 6–1).

The serial telegram is used to transmit the EEPROM content, error codes and digital values of the angle information from and to the sensor.

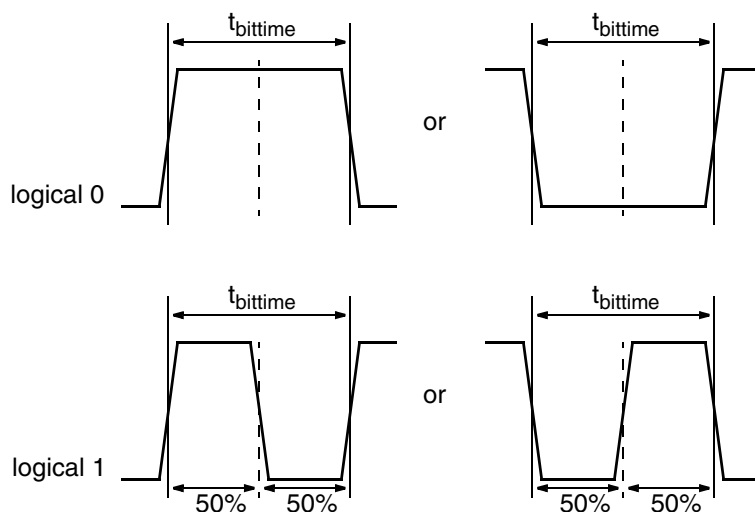

Fig. 6–1: Definition of logical 0 and 1 bit

A description of the communication protocol and the programming of the sensor is available in a separate document (Application Note: HAC 37xy Programming Guide).

Table 6–1: Telegram parameters (All voltages are referenced to GND.)

Symbol	Parameter	Pin	Limit Values			Unit
			Min.	Typ.	Max.	
V _{OUTL}	Sensor OUT Pin voltage for low level during programming	OUT	–	–	10	%VSUP
V _{OUTH}	Voltage for Output High Level during Programming through Sensor Output Pin	OUT	90	–	–	%VSUP
V _{SUPProgram}	V _{SUP} Voltage for EEPROM programming (during Programming)	OUT	5.7	6.0	6.5	V
	Slew rate	OUT	–	2	–	V/μs

6.2. Programming Environment and Tools

For the programming of HAC 37xy during product development a programming tool including hardware and software is available on request. It is recommended to use the TDK-Micronas tool kit (TDK-MSP V1.0 or USB kit and Lab View Programming Environment) in order to facilitate the product development. The details of programming sequences are also available on request.

6.3. Programming Information

For production and qualification tests, it is mandatory to set the LOCK bit to one after final adjustment and programming of HAC 37xy.

Before locking the device, it is recommended to read back all register values to ensure that the intended data is correctly stored in the sensor's memory. Alternatively, it is also possible to cross-check the sensor output signal with the intended output behavior.

The success of the LOCK process shall be checked by reading the status of the LOCK bit after locking.

Even after locking the device it is still possible to read the memory content.

It is also mandatory to check the acknowledge (first and second) of the sensor after each write and store sequence to verify if the programming of the sensor was successful. To enable debugging of the production line, it is recommended to read back the PROG_DIAGNOSIS register in case of a missing second acknowledge.

Electrostatic Discharges (ESD) may disturb the programming pulses. Please take precautions against ESD.

7. Document History

1. Data Sheet: "HAC 371x, HAC 372x, HAC 373x, Robust Programmable 2D Position Sensor Family with Integrated Capacitors", Jan. 23, 2019. First release of the Data Sheet.

Major Changes:

- Ambient temperature range defined
- Fig. 3–2: Signal path of HAC 37xy updated
- DNC filter registers renamed
- Values for Absolute Maximum Ratings, Recommended Operating Conditions, and Characteristics updated
- Table 6–1: Telegram parameters updated

2. Data Sheet: "HAC 371x, HAC 372x, HAC 373x, Robust Programmable 2D Position Sensor Family with Integrated Capacitors", April 26, 2021. Second release of the Data Sheet.

Major Changes:

- Disclaimer updated
- Two new capacitor combinations added with 330 nF on VSUP
- Laser marking information changed (capacitor combination instead of temperature range)
- Functional Safety information added
- Tape & Reel finishing information added
- Chapter 4.5: Definition of B_Z corrected
- Absolute Maximum Ratings: B_{max} changed