

REVISION HISTORY

Rev	Date	Revision Items	Editor
1.0	2022/11/18	Preliminary SPEC Released.	Gang.Li
1.1	2023/2/17	Update optical characteristics.	Gang.Li
1.2	2023/6/14	P4: 1.2 Features Delete UL information in pre-spec. P5: 2. General Specifications Power Consumption LCD: T.B.D.=>3.84 Power Consumption Backlight: T.B.D.=>(43.2) P8: 3.3 CN202 Pin assignment (Backlight control) PCAP control => Luminace control P10: DC Characteristics for Backlight Driving VDDDB Typ. 24=>12; Max. 25.2 =>13.2 IDDB Typ. T.B.D.=> (3600) P12: 5.3 Luminance Control Add "Note3: Range of each parameter". P15 5.6 Fuse Add fuse information. P17: 6.4LVDS AC Characteristics tRCIP Min. 12=>12.86; Max. 22=>14.42 P20: 7. Optical Characteristics Update spec. of Chromaticity, NTSC.	Zhou Jie
2.0	2024/4/25	P5: 2. General Specifications Weight: T.B.D. => 1860 Power Consumption of backlight: Remove () P10: 5.2 DC Characteristics for Backlight Driving IDDB: Typ. (3600), Max. T.B.D.=> Typ. 3600, Max. 4000. P20: 7. Optical Characteristics Chromaticity White: Remove "()"	Zhou Jie
2.1	2026/3/9	P5: Power Consumption LCD: 3.84=> 3.2; Backlight: 43.2=> 35.0 P7: Revise pin41 of CN1. P10: IDD Typ. 320=> 265 IDDB Typ. 3600=> 3060, Max. 4000=> 3360	Zhou Jie

CONTENTS

1. SUMMARY	1
1.1 General Description	1
1.2 Features	1
2. GENERAL SPECIFICATIONS	2
3. INPUT / OUTPUT TERMINALS	3
3.1 CN1 Pin assignment (LCD Interface).....	3
3.2 CN201 Pin assignment (Back Light Power).....	4
3.3 CN202 Pin assignment (Backlight control)	5
4. ABSOLUTE MAXIMUM RATINGS	6
5. ELECTRICAL CHARACTERISTICS.....	7
5.1 DC Characteristics for Panel Driving	7
5.2 DC Characteristics for Backlight Driving	7
5.3 Luminance Control	8
5.4 Recommended Power ON/OFF Sequence	10
5.5 LCD Module Block Diagram.....	11
5.6 Fuse	12
6. TIMING CHARACTERISTICS.....	12
6.1 Input Timing Parameters	12
6.2 Input Timing Chart.....	13
6.3 LVDS Data Mapping.....	13
6.4 LVDS AC Characteristics	14
6.5 Display Colors	15
6.6 Display position	16
7. OPTICAL CHARACTERISTICS.....	17
8. RELIABILITY TEST	20
9. MECHANICAL DRAWING	22
10. PACKING INSTRUCTION	24
11. PRECAUTIONS FOR USE OF LCD MODULES.....	25
11.1 Handling Precautions	25
11.2 Storage precautions	25
11.3 Transportation Precautions	25
11.4 Screen saver Precautions	25
11.5 Safety Precautions	25

1. Summary

1.1 General Description

This is a 21.3 inch a-Si TFT-LCD module with normal-black technology. It is composed of a TFT-LCD panel, a driver circuit, PCB, and a LED backlight unit. It is designed for medical diagnosis applications.

1.2 Features

- Ultra-wide viewing angle
- High luminance
- High contrast ratio
- Long LED life time
- Interface: dual port LVDS
- LED driver integrated
- Surface treatment
- Compliant with the European RoHS Directive (2011/65/EU) and Delegated Directive (2015/863/EU, Amending Annex II of 2011/65/EU)

2. General Specifications

	Feature	Spec	Unit
Display Spec	Size	21.3 inches	-
	Resolution	1200(RGB)x1600	-
	Pixel Pitch	0.27072 x 0.27072	mm
	TFT Active Area	324.864 x 433.152	mm
	Technology Type	a-Si	-
	Pixel Configuration	R.G.B Vertical Stripe	-
	Display Mode	SFT, Normally Black	-
	Surface Treatment	Anti-Glare	-
	Viewing Direction	All Dircetion	-
Mechanical Characteristics	LCM (W x H x D)	336.1 x 453.0 x 10.5	mm
	Weight	1860	g
Optical Characteristics	Luminance	900	cd/m ²
	Contrast Ratio	2000:1	-
	NTSC	72	%
	Viewing Angle	89/89/89/89	degree
Electrical Characteristics	Interface	Dual port LVDS	-
	Color Depth	16.7 Million	color
	Power Consumption	LCD: 3.2 Backlight: 36.7	W

Table 2.1 General TFT Specifications

3. Input / Output Terminals

3.1 CN1 Pin assignment (LCD Interface)

Connector Information	
LCD Module connector	JAE: FI-RE41S-HF
Matching connector	JAE: FI-RE41HL or equivalent

Table 3.1.1 Connector information

No	Symbol	I/O	Description	Comment
1	GND	P	Ground	
2	DA0-	I	Odd pixel data A0- (R0~R5,G0)	
3	DA0+	I	Odd pixel data A0+(R0~R5,G0)	
4	GND	P	Ground	
5	DA1-	I	Odd pixel data A1- (G1~G5,B0,B1)	
6	DA1+	I	Odd pixel data A1+ (G1~G5,B0,B1)	
7	GND	P	Ground	
8	DA2-	I	Odd pixel data A2-(B2~B5,-,-,DE)	
9	DA2+	I	Odd pixel data A2+(B2~B5,-,-,DE)	
10	GND	P	Ground	
11	CKA-	I	Odd pixel clock-	
12	CKA+	I	Odd pixel clock+	
13	GND	P	Ground	
14	DA3-	I	Odd pixel data A3-(R6~R7,G6~G7,B6~B7)	
15	DA3+	I	Odd pixel data A3+(R6~R7,G6~G7,B6~B7)	
16	GND	P	Ground	
17	DB0-	I	Even pixel data B0-(R0~R5,G0)	
18	DB0+	I	Even pixel data B0+(R0~R5,G0)	
19	GND	P	Ground	
20	DB1-	I	Even pixel data B1-(G1~G5,B0,B1)	
21	DB1+	I	Even pixel data B1+(G1~G5,B0,B1)	
22	GND	P	Ground	
23	DB2-	I	Even pixel data B2-(B2~B5,-,-,DE)	
24	DB2+	I	Even pixel data B2+(B2~B5,-,-,DE)	
25	GND	P	Ground	
26	CKB-	I	Even pixel clock-	
27	CKB+	I	Even pixel clock+	
28	GND	P	Ground	
29	DB3-	I	Even pixel data B3-(R6~R7,G6~G7,B6~B7)	
30	DB3+	I	Even pixel data B3+(R6~R7,G6~G7,B6~B7)	
31	GND	P	Ground	

Industrial Display Module

32	NC	N	No connection	
33	RSVD	N	For internal use. Please leave this pin open.	
34	NC	N	No connection	
35	VDD	P	+12V power supply input	
36	VDD	P	+12V power supply input	
37	VDD	P	+12V power supply input	
38	VDD	P	+12V power supply input	
39	VDD	P	+12V power supply input	
40	GND	P	Ground	
41	GND	P	Ground	

Table 3.1.2 Pin Assignment for LCD Interface

Note1: I/O definition: I---Input, O---Output, P---Power/Ground, N---No connection

Note2: All of the GND pins should be connected to the system ground.

3.2 CN201 Pin assignment (Back Light Power)

Connector Information	
LCD Module connector	Hirose: DF3EA-10P-2H(21)
Matching connector	Hirose: DF3-10S-2C or equivalent

Table 3.2.1 Connector information

No	Symbol	I/O	Description	Comment
1	GNDB	P	LED driver ground	
2	GNDB	P		
3	GNDB	P		
4	GNDB	P		
5	GNDB	P		
6	VDDDB	P	LED driver power supply(+12~24V)	
7	VDDDB	P		
8	VDDDB	P		
9	VDDDB	P		
10	VDDDB	P		

Table 3.2.2 Pin Assignment for Back Light Interface

Note1: I/O definition: I---Input, O---Output, P---Power/Ground, N---No connection

Note2: All of the GND pins should be connected to the system ground.

3.3 CN202 Pin assignment (Backlight control)

Connector Information	
Backlight connector	Molex: 53261-0971
Matching connector	Molex: 51021-0900 or equivalent

Table 3.3.1 Connector information

No	Symbol	I/O	Description	Remark
1	PWSEL	I	Selection of luminance control signal method	
2	GNDB	P	LED driver ground	
3	B RTP	I	B RTP signal	
4	B RTI	I	Luminance control terminal	
5	B RTH	I		
6	B RTC	I	Backlight ON/OFF control signal	
7	NC	N	No connection	
8	GNDB	P	LED driver ground	
9	GNDB	P		

Table 3.3.2 Pin Assignment for Backlight Interface

Note1: I/O definition: I---Input, O---Output, P---Power/Ground, N---No connection

Note2: All of the GND pins should be connected to the system ground.

Note3: Connector pin location as below.

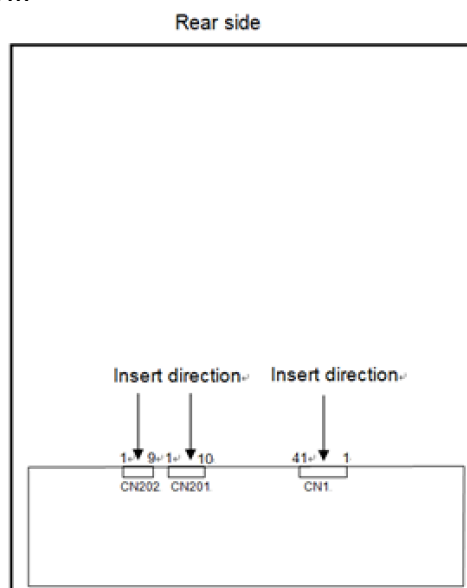

Figure 3.3 Connector pin location

4. Absolute Maximum Ratings

Item		Symbol	Rating	Unit	Remark	
Power supply voltage	LCD panel signal processing board	VDD	-0.3 to +15.0	V	Ta= 25°C	
	LED driver	VDDDB	-0.3 to +28.0	V		
Input voltage for signals	LCD panel signal processing board Note1	Vi	-0.3 to +2.8	V	VDD= 12.0V Ta= 25°C	
	LED driver	BRTI signal	VBI	-0.3 to +1.5	V	VDDDB=12~24.0V Ta= 25°C
		BRTP signal	VBP	-0.3 to +5.5	V	
		BRTC signal	VBC	-0.3 to +5.5	V	
PWSEL signal	VBS	-0.3 to +5.5	V			
Storage temperature		Tst	-20 to +60	°C	-	
Operating temperature	Center of front surface	TopF	0 to +60	°C		
	Edge of front surface	TopF	0 to +65	°C		
	Edge of rear surface	TopR	0 to +70	°C		
Relative humidity Note4, Note6		RH	≤ 95	%	Ta ≤ 40°C	
			≤ 85	%	40°C < Ta ≤ 50°C	
			≤ 55	%	50°C < Ta ≤ 60°C	
Absolute humidity Note4, Note6		AH	≤ 70	g/m3	Ta > 60°C	
Operating altitude		-	≤ 5,100	m	0°C ≤ Ta ≤ 60°C	
Storage altitude		-	≤ 13,600	m	-20°C ≤ Ta ≤ 60°C	

Table 4.1 Absolute Maximum Ratings

Note1: Input voltage include all in put data.

Note2: Ta means the ambient temperature. It is necessary to limit the relative humidity to the specified temperature range. Condensation on the module is not allowed.

Note3: The absolute maximum rating values of this product are not allowed to be exceeded at any times. A module should be used with any of the absolute maximum ratings exceeded, the characteristics of the module may not be recovered, or in an extreme condition, the module may be permanently destroyed

5. Electrical Characteristics

5.1 DC Characteristics for Panel Driving

Item		Symbol	MIN	TYP	MAX	Unit	Remark
Supply Voltage		VDD	10.8	12.0	13.2	V	With ripple
Power Supply Current		IDD	--	265	500	mA	White pattern
Input Signal Voltage	Low Level	VIL	DGND	--	0.3×VDD	V	
	High Level	VIH	0.7×VDD	--	VDD	V	
Input LVDS voltage swing		VI	100	-	600	mV	
Power Consumption	60Hz	P	--	3840	--	mW	Black pattern

Table 5.1.1 Panel driving Voltages

5.2 DC Characteristics for Backlight Driving

Item		Symbol	MIN	TYP	MAX	Unit	Remark	
Power supply voltage		VDDDB	10.8	12.0	13.2	V	-	
Power supply current		IDDB	-	3060	3360	mA	VDDDB= 12.0V, maximum luminance	
Permissible ripple voltage		VRPB	-	-	200	mVp-p	-	
Input voltage for signals	BRTI signal		VBI	0	-	1.0	V	-
	BRTP signal	High	VBPH	2.0	-	5.25	V	
		Low	VBPL	0	-	0.8	V	
	BRTC signal	High	VBCH	2.0	-	5.25	V	
		Low	VBCL	0	-	0.8	V	
	PWSEL signal	High	VBSH	2.0	-	5.25	V	
Low		VBSL	0	-	0.8	V		
PWM Frequency		FPWM	185	-	20000	HZ	-	
PWM Duty Ratio		DPWM	21	-	100	%	-	
LED life time		Hr		50000		hours	Note 6	

Table 5.2.1 LED Backlight Characteristics

Note1: Optical performance should be evaluated at Ta=25°C only.

Note2: If LED is driven by high current, high ambient temperature & humidity condition. The life time of LED will be reduced.

Note3: Operating life means brightness goes down to 50% of initial brightness.

5.3 Luminance Control

Method	Adjustment and luminance ratio	PWSEL terminal	B RTP terminal						
Variable resistor control	<ul style="list-style-type: none"> Adjustment The variable resistor (R) for luminance control should be $10k\Omega \pm 5\%$, 1/10W. Minimum point of the resistance is the minimum luminance and maximum point of the resistance is the maximum luminance. The resistor (R) must be connected between BRTH-BRTI terminals.  <ul style="list-style-type: none"> Luminance ratio: <table border="1"> <thead> <tr> <th>Resistance</th> <th>Luminance ratio</th> </tr> </thead> <tbody> <tr> <td>0Ω</td> <td>10% (typ.)</td> </tr> <tr> <td>10kΩ</td> <td>100%</td> </tr> </tbody> </table>	Resistance	Luminance ratio	0Ω	10% (typ.)	10kΩ	100%	High or Open	Open
Resistance	Luminance ratio								
0Ω	10% (typ.)								
10kΩ	100%								
Voltage control	<ul style="list-style-type: none"> Adjustment Voltage control method works, when BRTH terminal is 0V and VBI voltage is input between BRTI-BRTH terminals. This control method can carry out continuation adjustment of luminance. Luminance is the maximum when BRTI terminal is Open. Luminance ratio: <table border="1"> <thead> <tr> <th>BRTI Voltage (VBI)</th> <th>Luminance ratio</th> </tr> </thead> <tbody> <tr> <td>0V</td> <td>10% (typ.)</td> </tr> <tr> <td>1.0V</td> <td>100%</td> </tr> </tbody> </table>	BRTI Voltage (VBI)	Luminance ratio	0V	10% (typ.)	1.0V	100%		
BRTI Voltage (VBI)	Luminance ratio								
0V	10% (typ.)								
1.0V	100%								
Pulse width modulation (PWM) Note3	<ul style="list-style-type: none"> Adjustment Pulse width modulation (PWM) method works, when PWSEL terminal is Low and PWM signal (B RTP signal) is input into B RTP terminal. The luminance is controlled by duty ratio of B RTP signal. Keep BRTI and BRTH terminals Open when using PWM method. 	Low	B RTP signal						

Table 5.3.1 Luminance control

Note1: In case of the variable resistor control method and the voltage control method, noises may appear on the display image depending on the input signals timing for LCD panel signal processing board.

Use Pulse width modulation (PWM) method, if interference noises appear on the display image!

Note2: The LED driver will stop working, if the Low period of B RTP signal is more than 50ms while BRTC signal is High or Open. Then the backlight will not turn on anymore, even if B RTP signal is input again. This is not out of order. The LED driver will start to work when power is supplied again.

Note3: B RTP timing as below:

5.4 Recommended Power ON/OFF Sequence

5.4.1 LCD power on/off

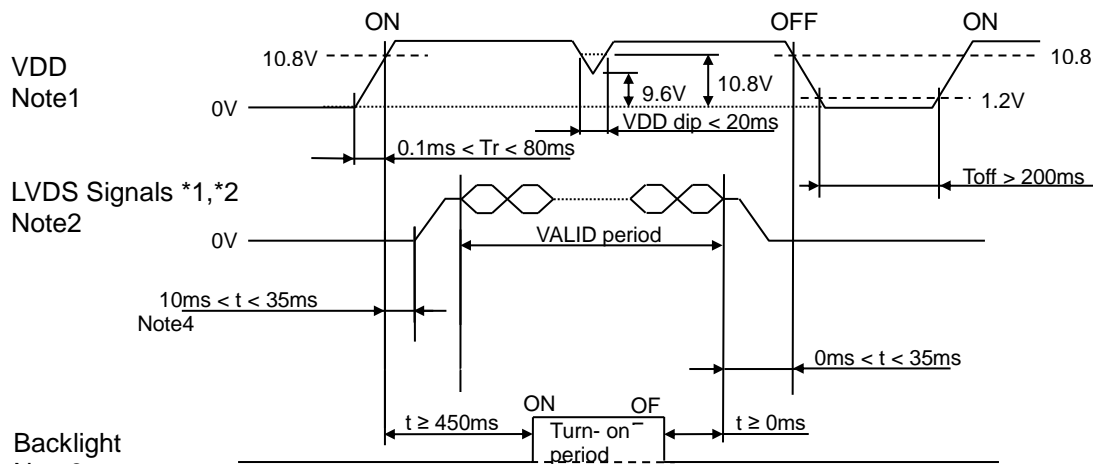

Figure 5.4.1 LCD power on/off

- *1: DA0+/-, DA1+/-, DA2+/-, DA3+/-, CKA+/-, DB0+/-, DB1+/-, DB2+/-, DB3+/-, CKB+/-,
- *2: LVDS signals should be measured at the terminal of 100 Ω resistance.

- Note1: If there is a voltage variation (voltage drop) at the rising edge of VDD below 10.8V, there is a possibility that a product does not work due to a protection circuit.
- Note2: LVDS signals must be set to Low or High-impedance, except the VALID period (See above sequence diagram), in order to avoid the circuitry damage. If some of signals are cut while this product is working, even if the signal input to it once again, it might not work normally. If a customer stops the display and function signals, VDD also must be shut down.
- Note3: The backlight should be turned on within the turn-on period, in order to avoid unstable data display.
- Note4: After turning VDD on, terminal voltages on LVDS input terminals (*1) will rise. This is caused by initial operation of the product.

5.4.2 Backlight on/off

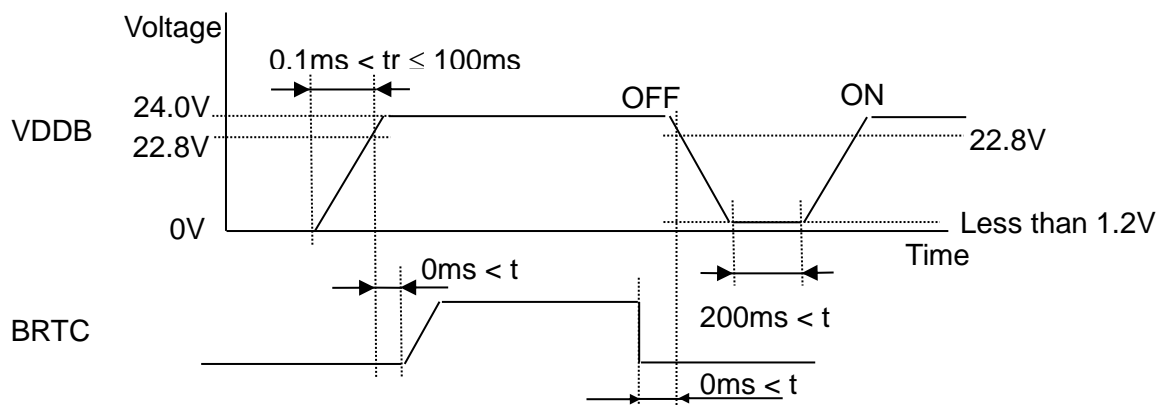

Figure 5.4.1 Backlight on/off

- Note1: If tr is more than 100ms, the backlight will be turned off by a protection circuit for LED driver.
- Note2: When VDDDB is 0V or BRTC is Low, PWSEL must be set to Low or Open.

5.5 LCD Module Block Diagram

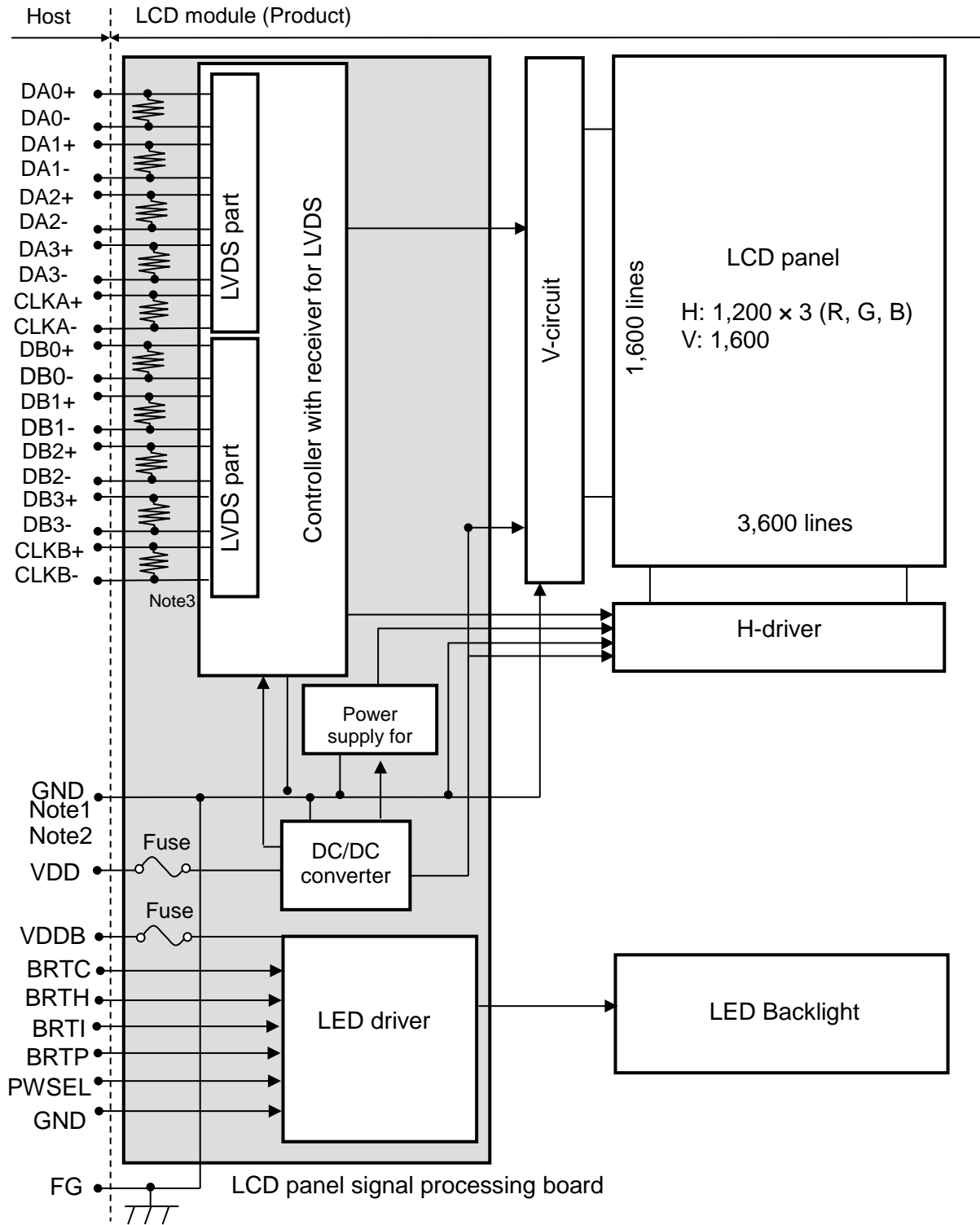

Figure 5.5.1 LCD Module Block Diagram

Note1: Relations between GND (Signal ground), FG (Frame ground) and GNDB (LED driver ground) in the LCD module are as follows.

GND - FG	Connected
GND - GNDB	Not connected
FG - GNDB	Not connected

Note2: GND, FG and GNDB must be connected to customer equipment's ground, and it is recommended that these grounds to be connected together in customer equipment.

Note3: Each pair of the LVDS signal lines has 100Ω terminating resistance.

5.6 Fuse

Parameter	Fuse		Rating	Fusing current	Remarks
	Type	Supplier			
VDD	FCC16152AB TP	KAMAYA	1.5A	3A @ 5 seconds max	Note1
			36V		
VDDDB	CRUCQ12LV 3A63V	CONQUER.	3A	6A@ 5 seconds max	
			63V		

Table 5.6.1 Fuse

Note1: The power supply's rated current must be more than the fusing current. If it is less than the fusing current, the fuse may not blow in a short time, and then nasty smell, smoke and so on may occur.

6. Timing Characteristics

6.1 Input Timing Parameters

Parameter		Symbol	Min.	Typ.	Max.	Unit	Remarks	
CLK	Frequency	1/ tc	69.36	73.5	77.76	MHz	Tc=13.6ns (type)	
DE	Horizontal	Cycle	th	-	9.54	-	μs	
		Display period	thd	680	700	720	CLK	
	Vertical (One frame)	Cycle	tv		16.7		ms	60.0Hz typ
		Display period	tvd	1700	1750	1800	H	
	CLK-DE	Setup time	-	See the data sheet of LVDS transmitter.			ns	-
		Hold time	-				ns	-
Rise time, Fall time		-				ns	-	

Table 6.1.1 Input Timing Parameters

Note1: Definition of parameters is as follows.

tc= 1CLK, th= 1H

Note2: See the data sheet of LVDS transmitter.

Note3: Vertical cycle (tv) should be specified in integral multiple of Horizontal cycle (th).

6.2 Input Timing Chart

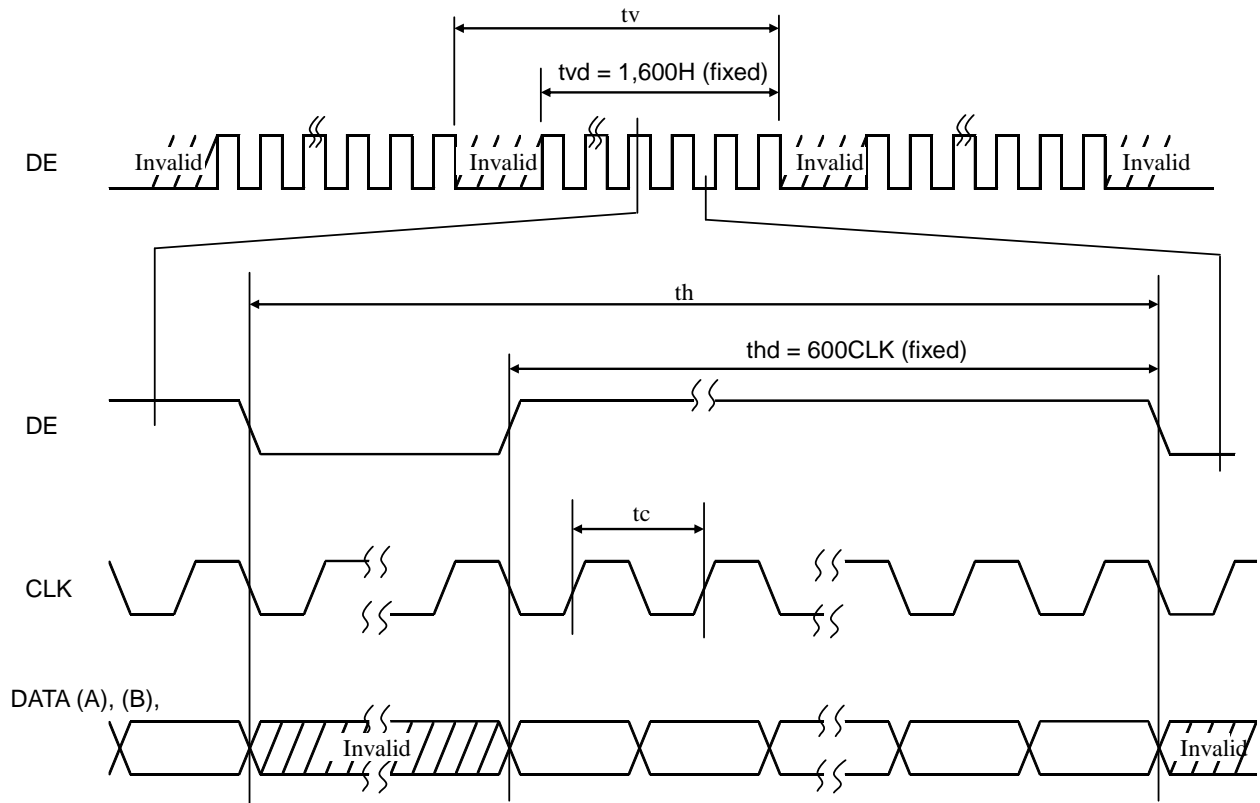

Figure 6.2.1 Data Input Timing Parameters

6.3 LVDS Data Mapping

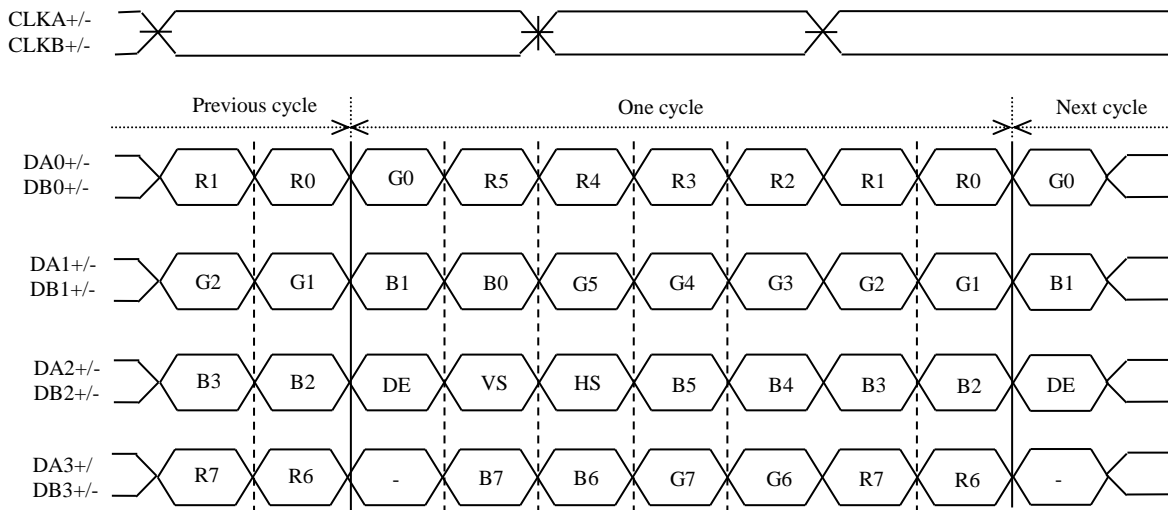

Figure 6.3.1 LVDS Data Mapping

6.4 LVDS AC Characteristics

Symbol	Parameter	min.	typ.	max.	Unit
tRCIP	CKy_+ Period	12.86	-	14.42	ns
tRCIH	CKy_+ High pulse width	-	$\frac{4}{7} t_{RCIP}$	-	ns
tRCIL	CKy_+ Low pulse width	-	$\frac{3}{7} t_{RCIP}$	-	ns
tRMG	Receiver Data Input Margin	-0.4	-	0.4	ns
tRIP1	Input Data Position 0	- tRMG	0.0	+ tRMG	ns
tRIP0	Input Data Position 1	$\frac{t_{RCIP}}{7} - t_{RMG} $	$\frac{t_{RCIP}}{7}$	$\frac{t_{RCIP}}{7} + t_{RMG} $	ns
tRIP6	Input Data Position 2	$2 \frac{t_{RCIP}}{7} - t_{RMG} $	$2 \frac{t_{RCIP}}{7}$	$2 \frac{t_{RCIP}}{7} + t_{RMG} $	ns
tRIP5	Input Data Position 3	$3 \frac{t_{RCIP}}{7} - t_{RMG} $	$3 \frac{t_{RCIP}}{7}$	$3 \frac{t_{RCIP}}{7} + t_{RMG} $	ns
tRIP4	Input Data Position 4	$4 \frac{t_{RCIP}}{7} - t_{RMG} $	$4 \frac{t_{RCIP}}{7}$	$4 \frac{t_{RCIP}}{7} + t_{RMG} $	ns
tRIP3	Input Data Position 5	$5 \frac{t_{RCIP}}{7} - t_{RMG} $	$5 \frac{t_{RCIP}}{7}$	$5 \frac{t_{RCIP}}{7} + t_{RMG} $	ns
tRIP2	Input Data Position 6	$6 \frac{t_{RCIP}}{7} - t_{RMG} $	$6 \frac{t_{RCIP}}{7}$	$6 \frac{t_{RCIP}}{7} + t_{RMG} $	ns

Table 6.4.1 LVDS AC Characteristics

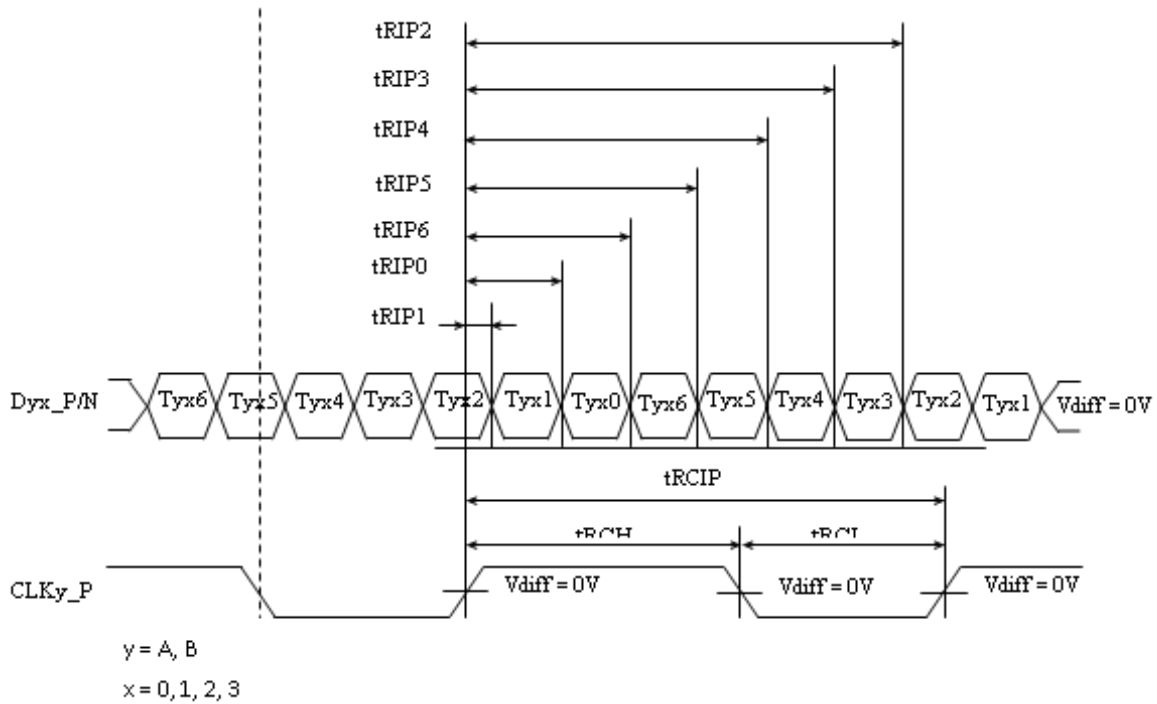

Figure 6.4.1 LVDS AC Characteristics

6.5 Display Colors

This product can display 256 gray scales in each RGB sub-pixel and 256 gray scales per 1 pixel. Also the relation between display gray scale and input data signals is as follows.

Display colors		Data signal (0: Low level, 1: High level)																							
		R7	R6	R5	R4	R3	R2	R1	R0	G7	G6	G5	G4	G3	G2	G1	G0	B7	B6	B5	B4	B3	B2	B1	B0
Basic Colors	Black	0	0	0	0	0	0	0	0	0	0	0	0	0	0	0	0	0	0	0	0	0	0	0	0
	Blue	0	0	0	0	0	0	0	0	0	0	0	0	0	0	0	0	1	1	1	1	1	1	1	1
	Red	1	1	1	1	1	1	1	1	0	0	0	0	0	0	0	0	0	0	0	0	0	0	0	0
	Magenta	1	1	1	1	1	1	1	1	0	0	0	0	0	0	0	0	1	1	1	1	1	1	1	1
	Green	0	0	0	0	0	0	0	0	1	1	1	1	1	1	1	1	0	0	0	0	0	0	0	0
	Cyan	0	0	0	0	0	0	0	0	1	1	1	1	1	1	1	1	1	1	1	1	1	1	1	1
	Yellow	1	1	1	1	1	1	1	1	1	1	1	1	1	1	1	1	0	0	0	0	0	0	0	0
	White	1	1	1	1	1	1	1	1	1	1	1	1	1	1	1	1	1	1	1	1	1	1	1	1
Red gray scale	Black	0	0	0	0	0	0	0	0	0	0	0	0	0	0	0	0	0	0	0	0	0	0	0	0
	dark	0	0	0	0	0	0	0	1	0	0	0	0	0	0	0	0	0	0	0	0	0	0	0	0
	↕																								
	bright	1	1	1	1	1	1	0	1	0	0	0	0	0	0	0	0	0	0	0	0	0	0	0	0
	Red	1	1	1	1	1	1	1	1	0	0	0	0	0	0	0	0	0	0	0	0	0	0	0	0
Green gray scale	Black	0	0	0	0	0	0	0	0	0	0	0	0	0	0	0	0	0	0	0	0	0	0	0	0
	dark	0	0	0	0	0	0	0	0	0	0	0	0	0	0	1	0	0	0	0	0	0	0	0	0
	↕																								
	bright	0	0	0	0	0	0	0	0	1	1	1	1	1	1	0	1	0	0	0	0	0	0	0	0
	Green	0	0	0	0	0	0	0	0	1	1	1	1	1	1	1	1	0	0	0	0	0	0	0	0
Blue gray scale	Black	0	0	0	0	0	0	0	0	0	0	0	0	0	0	0	0	0	0	0	0	0	0	0	0
	dark	0	0	0	0	0	0	0	0	0	0	0	0	0	0	0	0	0	0	0	0	0	0	1	0
	↕																								
	bright	0	0	0	0	0	0	0	0	0	0	0	0	0	0	0	0	1	1	1	1	1	1	0	1
	Blue	0	0	0	0	0	0	0	0	0	0	0	0	0	0	0	0	1	1	1	1	1	1	1	1

Table 6.5.1 Display colors

6.6 Display position

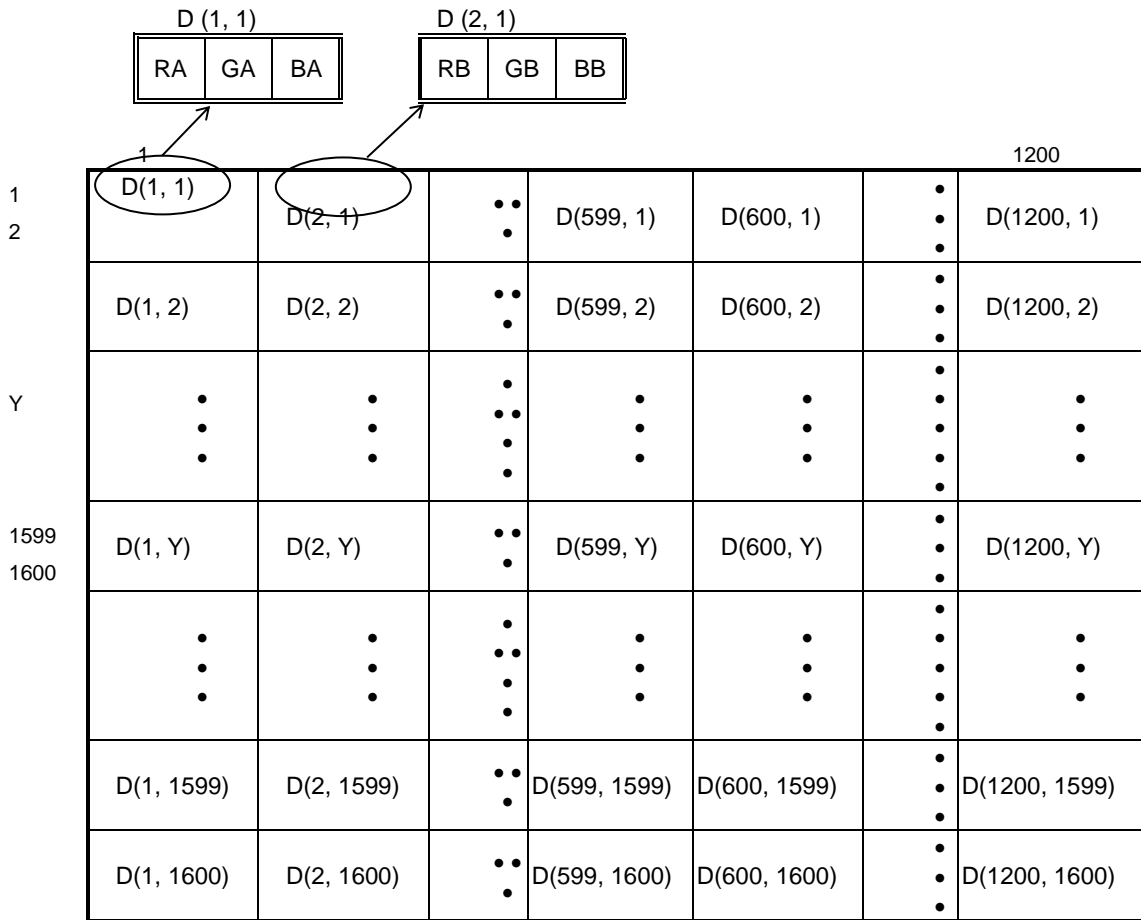

Table 6.6.1 Display Positions

7. Optical Characteristics

Item	Symbol	Condition	Min	Typ	Max	Unit	Remark	
View Angles	θT	CR≥10	70	88	-	Degree	Note 2	
	θB		70	88	-			
	θL		70	88	-			
	θR		70	88	-			
Contrast Ratio	CR	θ=0°	1400	2000	-	-	Note1 Note3	
Response Time	TON+TOFF	25°C	-	35	45	ms	Note1 Note4	
Chromaticity	White	Backlight is on	x	0.264	0.314	0.364	-	Note5 Note1
			y	0.276	0.326	0.376		
	Red		x	0.600	0.650	0.700		
			y	0.283	0.333	0.383		
	Green		x	0.275	0.325	0.375		
			y	0.575	0.625	0.675		
	Blue		x	0.100	0.150	0.200		
			y	0.010	0.060	0.110		
Uniformity	LU	White (255/255gray)	80	-	-	%	Note1 Note6	
NTSC	-	-	69	74	-	%	Note 5	
Luminance	L	White (255/255gray)	720	900	-	cd/m2	Note1 Note7	

Table 7.1 Optical Parameters

Test Conditions:

1. The ambient temperature is 25±2°C.humidity is 65±7%. PWM duty ratio is 100%.
2. The test systems refer to Note 1 and Note 2.
3. Contrast Ratio, Chromaticity, Uniformity, and Luminance is measured by SR-UL, SR-3AR or equivalent.
4. Response Time is measured by TRD-100, LCD-5200 or equivalent.

Note1: Definition of optical measurement system.

The optical characteristics should be measured in dark room. After 5 Minutes operation, the optical characteristics are measured at the center point of the LCD screen.

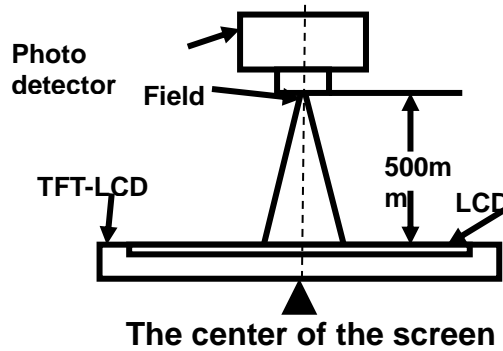

Fig1. Measurement Set Up

Note2: Definition of viewing angle range and measurement system. Viewing angle is measured at the center point of the LCD .

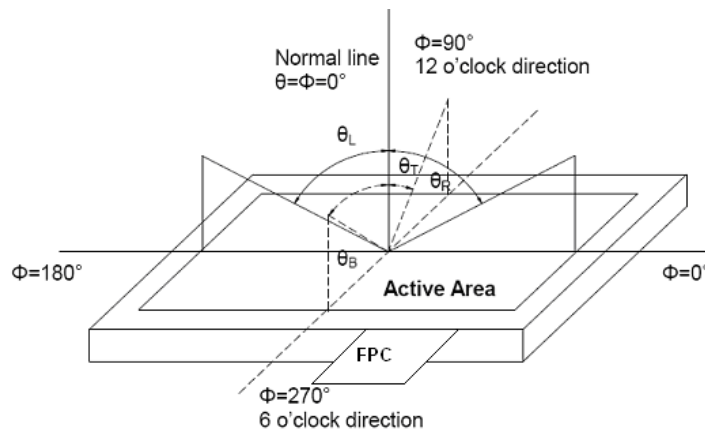

Fig2. Measurement viewing angle

Note3: Definition of contrast ratio

$$\text{Contrast ratio (CR)} = \frac{\text{Luminance measured when LCD is on the "White" state}}{\text{Luminance measured when LCD is on the "Black" state}}$$

Note4: Definition of Response time

The response time is defined as the LCD optical switching time interval between “White” state and “Black” state. Rise time (T_r) is the time between photo detector output intensity changed from 10% to 90%. And fall time (T_f) is the time between photo detector output intensity changed from 90% to 10%.

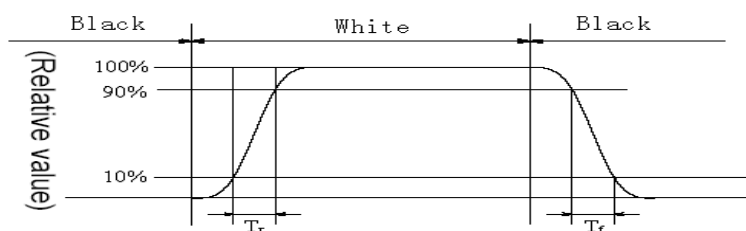

Fig4. Response Time Testing($T_a=25^\circ\text{C}$)

Note5: Definition of color chromaticity (CIE1931)

Color coordinates measured at center point of LCD.

Note6: Definition of Luminance Uniformity

Active area is divided into 9 measuring areas (Refer Fig. 2).

$$\text{Luminance Uniformity}(U) = L_{\min} / L_{\max}$$

L-----Active area length W----- Active area width

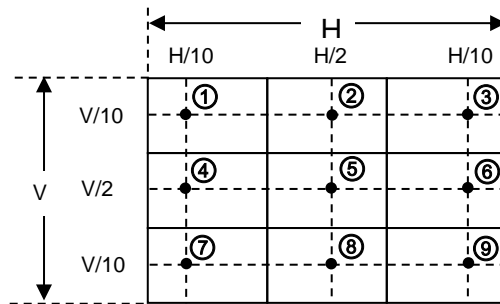

Fig. 5 Definition of uniformity

Note7: Definition of Luminance:

Measure the luminance of white state at center point.

8. Reliability Test

No	Test Item	Condition	Remarks
1	High Temperature Operation	+60°C , 240H	IEC60068-2-1:2007 GB2423.2-2008
2	Low Temperature Operation	-10°C , 240H	IEC60068-2-1:2007 GB2423.1-2008
3	High Temperature Storage	+60°C , 240H	IEC60068-2-1:2007 GB2423.2-2008
4	Low Temperature Storage	-20°C , 240H	IEC60068-2-1:2007 GB2423.1-2008
5	Storage at High Temperature and Humidity(non-operation)	+60°C , 60%RH , 240H	IEC60068-2-78 :2001 GB/T2423.3—2006
6	Thermal Shock (non-operation)	-20°C , 30min~60°C , 30min , change time : 5min , 100cycle	Start with cold temperature, End with high temperature, IEC60068-2-14:1984,GB2423.22-2002
7	ESD	C=150pF , R=330Ω , 5point/panel Air : ±15kv , 25times ; Contact : ±8kv , 25times ; (Environment : 15°C~35°C , 30%~60% , 86Kpa~106Kpa)	IEC61000-4-2:2001 GB/T17626.2-2006
8	Vibration (Non-operation)	5 to 100Hz, 11.76m/s ² 1 minute/cycle X, Y, Z directions 10 times each direction	-
9	Shock (Non-operation)	294m/s ² , 11ms ±X, ±Y, ±Z directions 3 times each direction	-
10	Package Vibration	5-20-200HZ , PSD : 0.01-0.01-0.001 Total:0.781g ² /HZ, x/y/z 30min)	-
11	Package Drop Test	Height: 60cm,1 corner, 3edges, 6 surfaces	IEC60068-2-32:1990 GB/T2423.8—1995
12	Low Pressure	Low pressure Non-operation ① 15kPa (Equivalent to altitude 13,600m) ② -20°C±3°C 24 hours ③ +60°C±3°C 24 hours operation ① 53.3kPa (Equivalent to altitude 5,100m) ② 0°C±3°C 24 hours ③ +60°C±3°C 24 hours	-

Table 8.1 RA test condition

Industrial Display Module

Note1: Temperature is the ambient temperature of sample

Note2: Before cosmetic and function test, the product must have enough recovery time, at least 2 hours at room temperature.

Note3: In the standard condition, there shall be no practical problem that may affect the display function. After the reliability test, the product's function only be guaranteed, but not for all of the cosmetic specification.

9. Mechanical Drawing
9.1 Mechanical Drawing Of LCM

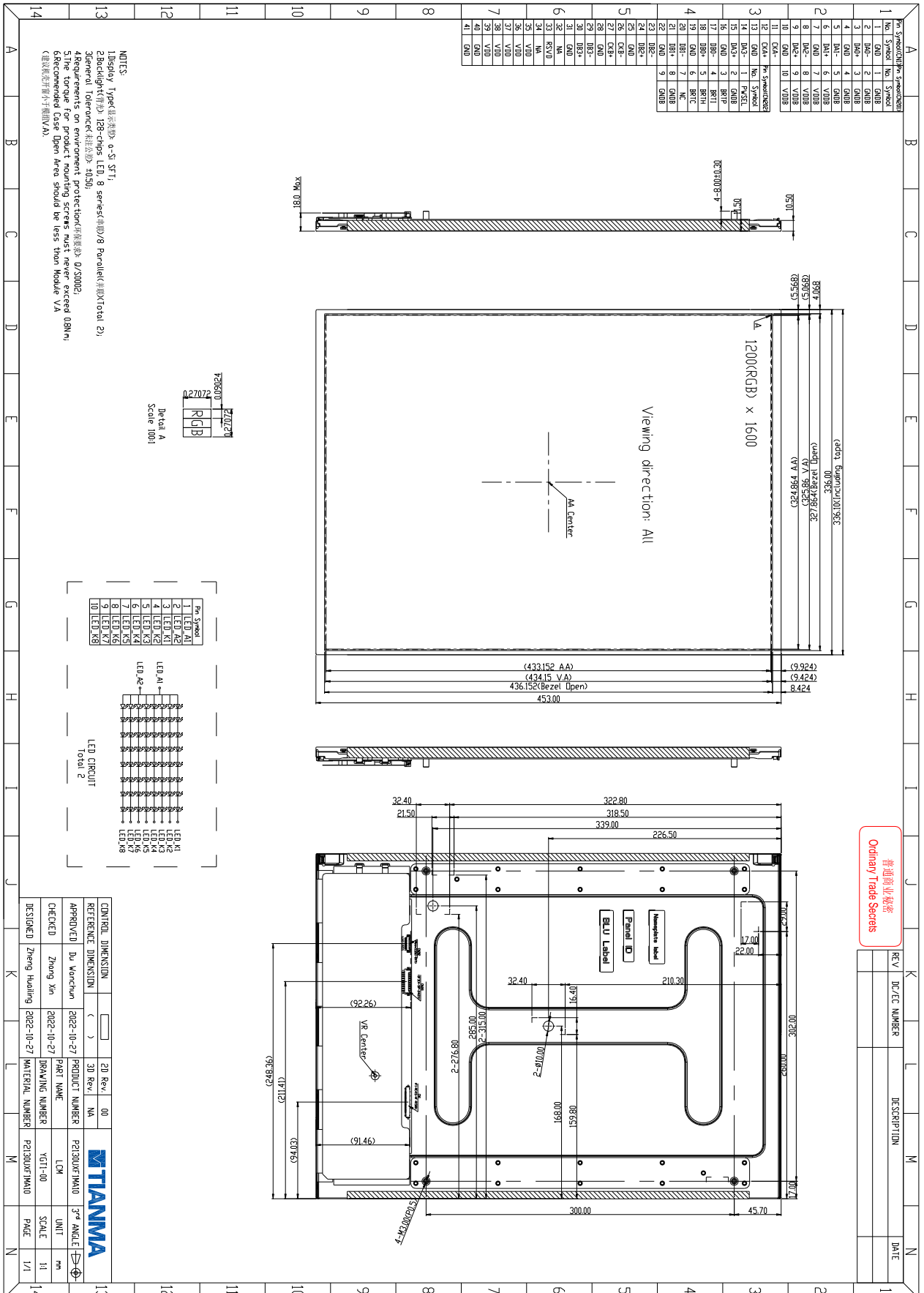

9.2 Markings

The marking is attached to this product.

9.2.1 Nameplate label



9.2.2 Barcode label



Note1: **Do not attach anything like another label on the nameplate label!**

10. Packing Instruction

No	Item	Model (Material)	Dimensions(mm)	Unit Weight(Kg)	Quantity	Remark	
1	LCM module	P2130UXF1MA10	453x336x10.5	1.86	5		
2	Partition board	Corrugated paper	460x378	0.075	2		
3	Anti-static Bag	LD-PE	600x420	0.022	5		
4	EPP-Bottom	EPP	597x410x190	0.34	1		
5	EPP-Top	EPP	410x185x110	0.064	2		
6	Carton-inside	Corrugated paper	612x425x520	1.65	1		
7	Barcode Label	Paper	76x104	0.001	2		
8	Total weight	11.68 ±10% kg					

Table 10.1 Packing Instruction

Packing method is shown as below:

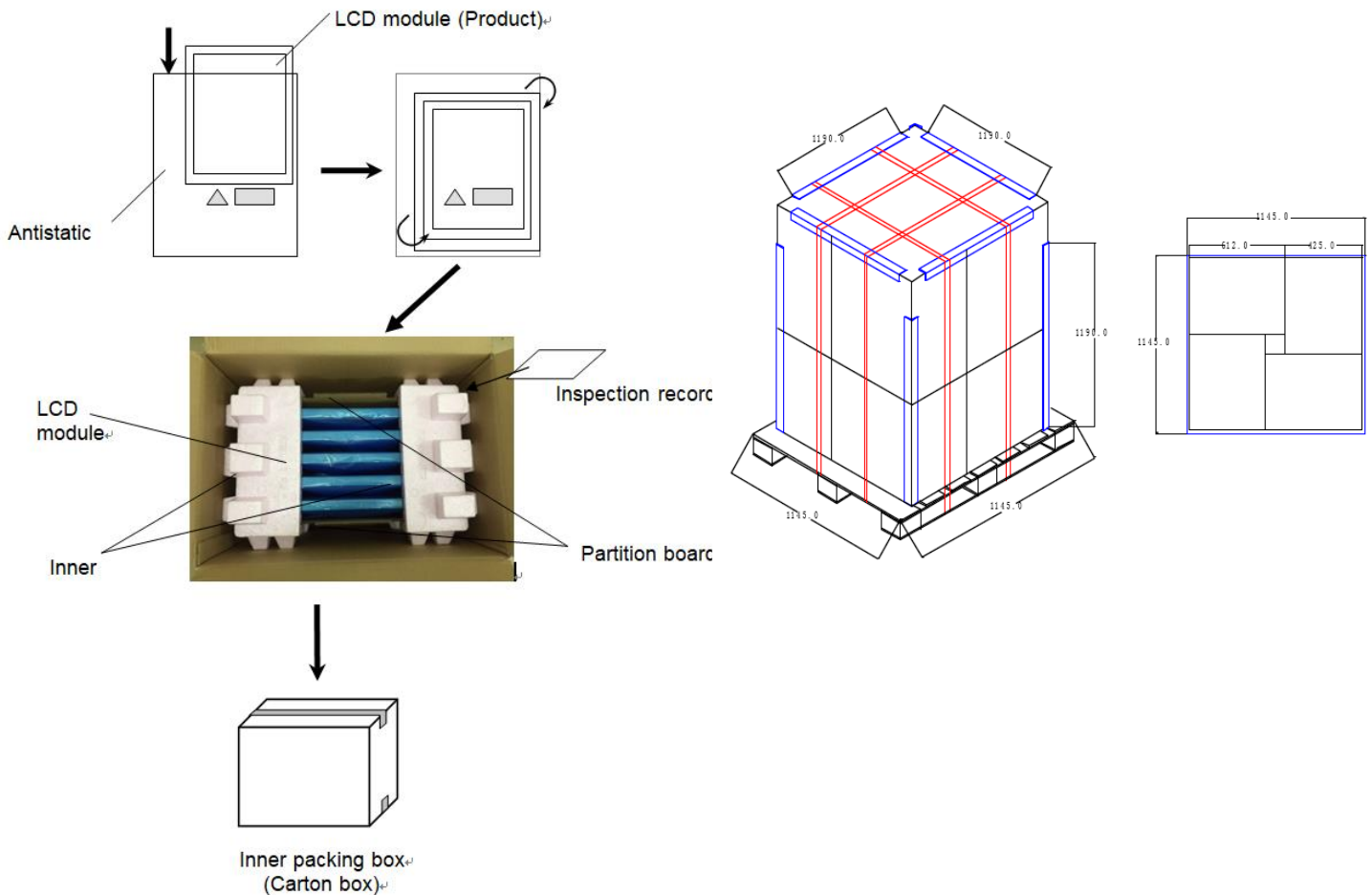

11. Precautions for Use of LCD Modules

11.1 Handling Precautions

- (1) The display panel is made of glass. Do not subject it to mechanical shock by dropping it, etc.
- (2) If the display panel is damaged and the liquid crystal fluid inside it leaks out be sure not to get any in your mouth. If the fluid comes into contact with your skin or clothes promptly wash it off using soap and water.
- (3) Do not apply excessive force to the display surface or the bezel since this may cause the color tone to vary.
- (4) The polarizer covering the display surface of the LCD module is soft and easily scratched. Handle the polarizer carefully.
- (5) If the display surface is contaminated, breathe on the surface and gently wipe it with a soft dry cloth. If it is still not completely clear use a moist cloth with one of the following solvents:
 - Isopropyl alcohol
 - Ethyl alcohol

Solvents other than those mentioned above may damage the polarizer. Specifically, do not use the following:

 - Water
 - Ketone
 - Aromatic solvents
- (6) Do not disassemble the LCD Module.
- (7) If powered off, do not apply the input signals.
- (8) To prevent destruction of the module by static electricity, be careful to maintain an optimum work environment.
- (9) Be sure to ground your body when handling the LCD Modules.
- (10) Tools used for assembly, must be properly grounded.
- (11) To reduce the amount of static electricity generated, do not conduct assembly or other work under very low humidity conditions.
- (12) The LCD Module is covered with a film to protect the display surface, remove film slowly under the ionizer.

11.2 Storage precautions

- (1) When storing the LCD modules avoid exposure to direct sunlight or to the light of fluorescent lamps.
- (2) The LCD modules should be stored within the rated storage temperature range. The recommend condition is: Temperature: 0 ~ 35 °C at normal humidity.
- (3) The LCD modules should be stored in a room without acid, alkali or other harmful gas.

11.3 Transportation Precautions

The LCD modules should not be dropped or subject to violent mechanical shock during transportation. Also they should avoid excessive pressure, water, high humidity and direct sunlight.

11.4 Screen saver Precautions

Not display the fixed pattern for a long time. Use a screen saver, if the fixed pattern is displayed on the screen

11.5 Safety Precautions

- (1) When you waste damaged or unnecessary LCDs, it is recommended to crush LCDs into pieces and wash them off with solvents such as acetone and ethanol, which should later be burned
- (2) Be sure to turn off the power supply when inserting or disconnecting the LED backlight cable.
- (3) LED driver should be designed to limit or stop its function when over current is detected on the LED.