

CONTENTS

1. SUMMARY.....	1
1.1 General Description.....	1
1.2 Features.....	1
2. GENERAL SPECIFICATIONS.....	2
3. INPUT / OUTPUT TERMINALS.....	3
3.1 CN1 Pin assignment (LCD Interface).....	3
3.2 CN2 Pin assignment (Back Light).....	4
4. ABSOLUTE MAXIMUM RATINGS	4
5. ELECTRICAL CHARACTERISTICS	5
5.1 DC Characteristics.....	5
5.2 Driving Backlight.....	5
5.3 Backlight Unit.....	6
5.4 Block Diagram	7
6. TIMING CHART	8
7. OPTICAL CHARACTERISTICS	12
8. RELIABILITY TEST.....	15
9. MECHANICAL DRAWING	16
10. PACKING INSTRUCTION.....	17
11. PRECAUTIONS FOR USE OF LCD MODULES.....	18
11.1 Handling Precautions.....	18
11.2 Storage precautions.....	18
11.3 Transportation Precautions	18
11.4 Screen saver Precautions.....	18
11.5 Safety Precautions	18

1. Summary

1.1 General Description

This is a 17.3 inch a-Si TFT-LCD module with Normal- Black technology. It is composed of a TFT-LCD panel, a driver circuit, PCB, and a LED backlight unit.

1.2 Features

- Ultra-wide viewing angle
- High resolution
- Interface: LVDS

- Acquisition product for UL62368-1/CSA C22.2 No.62368-1-03 (File number: E333987)
- Compliant with the European RoHS Directive (2011/65/EU) and Delegated Directive (2015/863/EU, Amending Annex II of 2011/65/EU)

2. General Specifications

	Feature	Spec	Unit
Display Spec	Size	17.3 inches	
	Resolution	1920(RGB)x1080	
	Pixel Pitch	0.1989*0.1989	mm
	TFT Active Area	381.888*214.812	mm
	Technology Type	a-Si	
	Pixel Configuration	RGB vertical strip	
	Display Mode	SFT, Normally Black	
	Surface Treatment	AG	
	Viewing Direction	All	
	Gray Scale Inversion Direction	NA	
Mechanical Characteristics	LCM (W x H x D)	388.888*225.812*4	mm
	Weight	575 +/-5%	g
Optical Characteristics	Luminance	500	cd/m ²
	Contrast Ratio	1700:1	
	NTSC	72	%
	Viewing Angle	89/89/89/89	degree
Electrical Characteristics	Interface	2 pot LVDS	
	Color Depth	16.7 Million	color
	Power Consumption	LCD:2000; Backlight:9150	mW

Table 2.1 General TFT Specifications

3. Input / Output Terminals

3.1 CN1 Pin assignment (LCD Interface)

Connector Information	
LCD Module connector	MSBKT2407P30HB
Matching connector	-

Table 3.1.1 Connector information

No	Symbol	I/O	Description	Comment
1	GND	P	Power Ground	
2	OLVDS0_N	I	-LVDS differential data input	
3	OLVDS0_P	I	+LVDS differential data	
4	OLVDS1_N	I	-LVDS differential data input	
5	OLVDS1_P	I	+LVDS differential data	
6	OLVDS2_N	I	-LVDS differential data input	
7	OLVDS2_P	I	+LVDS differential data	
8	GND	P	Power Ground	
9	OLVDSC_N	I	-LVDS differential clk input	
10	OLVDSC_P	I	+LVDS differential clk	
11	GND	P	Power Ground	
12	OLVDS3_N	I	-LVDS differential data input	
13	OLVDS3_P	I	+LVDS differential data	
14	GND	P	Power Ground	
15	ELVDS0_N	I	-LVDS differential data input	
16	ELVDS0_P	I	+LVDS differential data	
17	ELVDS1_N	I	-LVDS differential data input	
18	ELVDS1_P	I	+LVDS differential data	
19	ELVDS2_N	I	-LVDS differential data input	
20	ELVDS2_P	I	+LVDS differential data	
21	GND	P	Power Ground	
22	ELVDSC_N	I	-LVDS differential clk input	
23	ELVDSC_P	I	+LVDS differential clk	
24	GND	P	Power Ground	
25	ELVDS3_N	I	-LVDS differential data input	
26	ELVDS3_P	I	+LVDS differential data	
27	GND	P	Power Ground	
28	VLCD_5V	P	Power supply (5V)	
29	VLCD_5V	P	Power supply (5V)	
30	VLCD_5V	P	Power supply (5V)	

Table 3.1.2 Pin Assignment for LCD Interface

Note1: I/O definition: I---Input, O---Output, P---Power/Ground, N---No connection

Note2: All of the GND pins should be connected to the system ground.

Note3: This LCD module supports DE mode. Please refer to the descriptions.

3.2 CN2 Pin assignment (Back Light)

Connector Information	
LCD Module connector	KW30-8S-1H
Matching connector	KW30-8P-1C

Table 3.2.1 Connector information

No	Symbol	I/O	Description	Wire Color
1	LED_EN	I	EN	
2	LED_PWM	I	PWM	
3	GND	P	Power Ground	
4	GND	P	Power Ground	
5	GND	P	Power Ground	
6	VLED	P	Power supply (8.75~17V)	
7	VLED	P	Power supply (8.75~17V)	
8	VLED	P	Power supply (8.75~17V)	

Table 3.2.2 Pin Assignment for Back Light Interface

Note1: I/O definition: I---Input, O---Output, P---Power/Ground, N---No connection

Note2: All of the GND pins should be connected to the system ground.

4. Absolute Maximum Ratings

GND=0V

Item	Symbol	MIN	MAX	Unit	Remark
Power Voltage for LCD	VLCD_5V	-0.3	6.5	V	
Power Voltage for Backlight	VLED	0	20	V	
Power Voltage for CTP	VDD	-0.3	3.4	V	
Interface Power supply voltage for LCD	VDDR_X	-0.3	2.8	V	Note1
Interface Power supply voltage for Backlight	VIN1	-0.3	20	V	Note2

Table 4.1 Absolute Maximum Ratings

Note1: VDDR_X included OLVDS0_N/P、OLVDS1_N/P、OLVDS2_N/P、OLVDS3_N/P、OLVDSC_N/P、ELVDS0_N/P、ELVDS1_N/P、ELVDS2_N/P、ELVDS3_N/P、ELVDSC_N/P

Note2: VIN1 included LED_EN、LED_PWM

5. Electrical Characteristics

5.1 Driving LCD Panel

Parameter	Symbol	Min	Typ	Max	Unit	Remark
Power Voltage for LCD	VLCD_5V	4.5	5	5.5	V	
Power Consumption	White Mode (60Hz)	-	2000	-	mW	At 5V
Inrush	VLCD_5V			1.5	A	

Note 1:

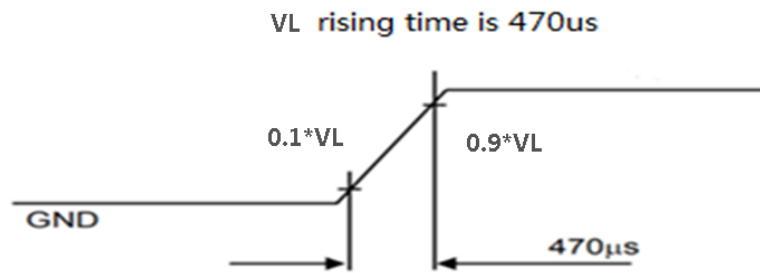

Table 5.1.1 Operating Voltages

5.2 Driving Backlight

Ta=25°C

Parameter	Symbol	Min	Typ	Max	Unit	Remark
Power Voltage for Backlight	VLED	14.5	15	16.5	V	
LED driver current	I_VLED	-	610	-	mA	
Power consumption	P_VLED	-	9150	-	mW	
Logic-High Input Voltage for Backlight	VIH_BL	2.0	-	VLED	V	Note 1
Logic-Low Input Voltage for Backlight	VIL_BL	-	-	0.5	V	Note 1
LED_PWM frequency	FPWM	100		20K	Hz	
LED_PWM duty	D	1		100	%	Note 2

Note 1: VIH_BL and VIL_BL included LED_EN, LED_PWM

Note2: Without considering linearity:

LED_PWM frequency	LED_PWM Duty
100Hz~1KHz	0.1%~100%
1KHz~10KHz	1%~100%
10KHz~30KHz	3%~100%

Consider linearity:

LED_PWM frequency	LED_PWM Duty
100Hz~1KHz	1%~100%
1KHz~5KHz	5%~100%
5KHz~30KHz	15%~100%

5.3 Backlight Unit

Ta=25°C

Item	Symbol	MIN	TYP	MAX	Unit	Remark
Forward Current	IF	-	20	-	mA	One LED
Forward Voltage	VF	5.4	5.7	6	V	One LED
Backlight Power Consumption	WBL	-	114	-	mW	One LED
Backlight Power Consumption	WBL	-	8208	-	mW	72 LEDs (12 LED Parallel,6 LED Serial)
LED life time	-	-	30000		Hrs	

Table 5.3 Backlight Unit Electrical Characteristics

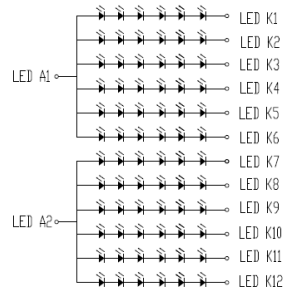
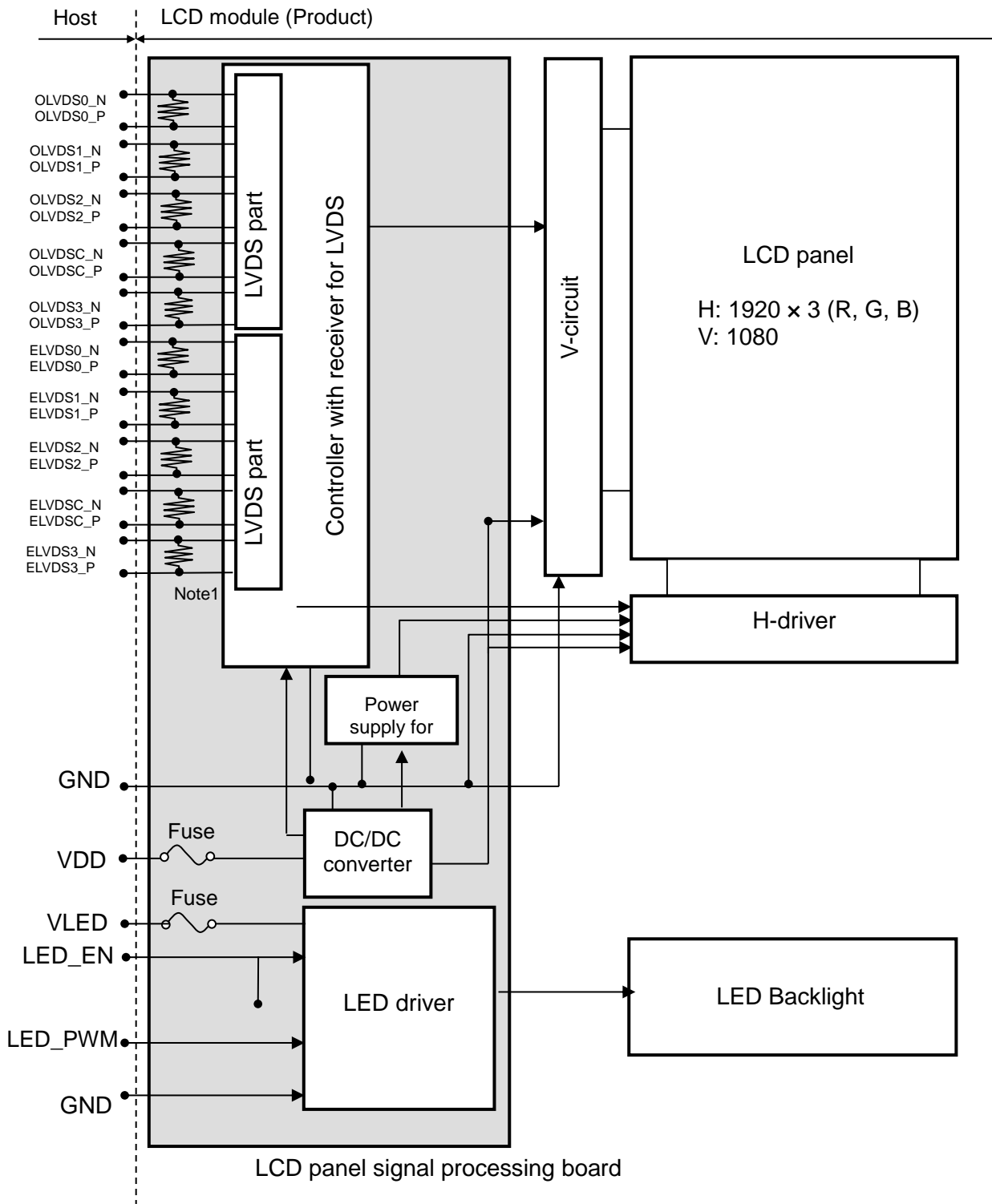

Figure 5.3.1 LED Current

5.4 Block Diagram



Note1: Each pair of the LVDS signal lines has 100Ω terminating resistor

6. Timing Chart

6.1 LVDS DC Electrical Characteristics

Parameter	Symbol	Min.	Typ.	Max.	Unit	Remark
Differential input high Threshold voltage	R_{XVTH}	-	-	0.1	V	
Differential input Low Threshold voltage	R_{XVTL}	-0.1	-	-	V	
Input voltage range(single-end)	R_{XVIN}	0	-	VCC_LVDS	V	VCC_LVDS=3.3V
Differential input common Mode voltage	R_{XVCM}	-	1.2	VCC_LVDS 0.4- VID /2	V	
Differential input voltage	$ V_{ID} $	0.1	-	0.6	V	
Differential input leakage current	R_{Vxliz}	-10	-	10	uA	

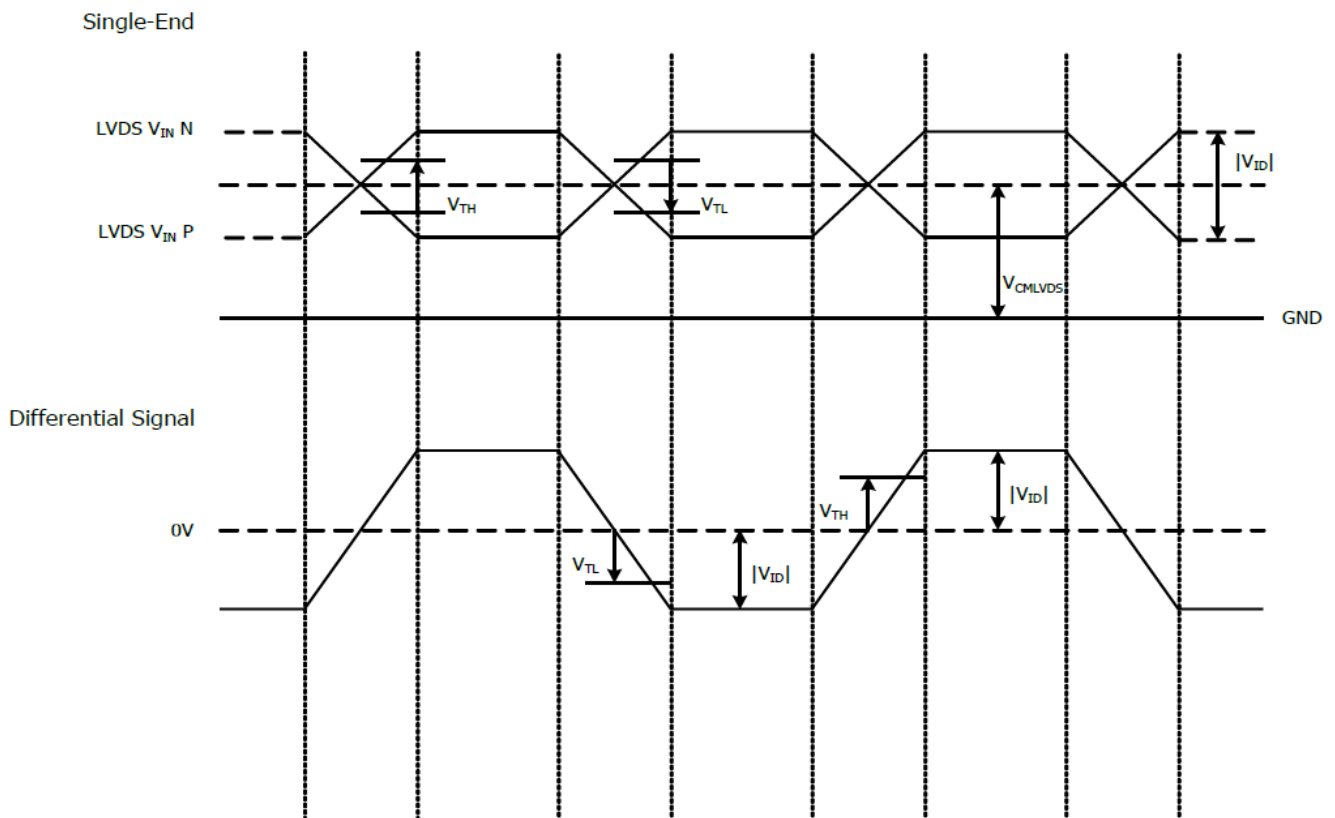

6.2 LVDS AC Electrical Characteristics

Parameter	Symbol	Min.	Typ.	Max.	Unit	Conditions
Clock Period	T_{lvcp}	12.6	T	13.9	ns	
Clock high time	T_{LVCH}	4T/7			ns	
Clock low time	T_{LVCL}	3T/7			ns	
PLL Wake-Up Time	T_{lvpll}	-	-	1	ms	
Srtobe Width	T_{sw}	200	-	-	ps	
Receiver Strobe Margin	T_{rsm}	400	-	-	ps	

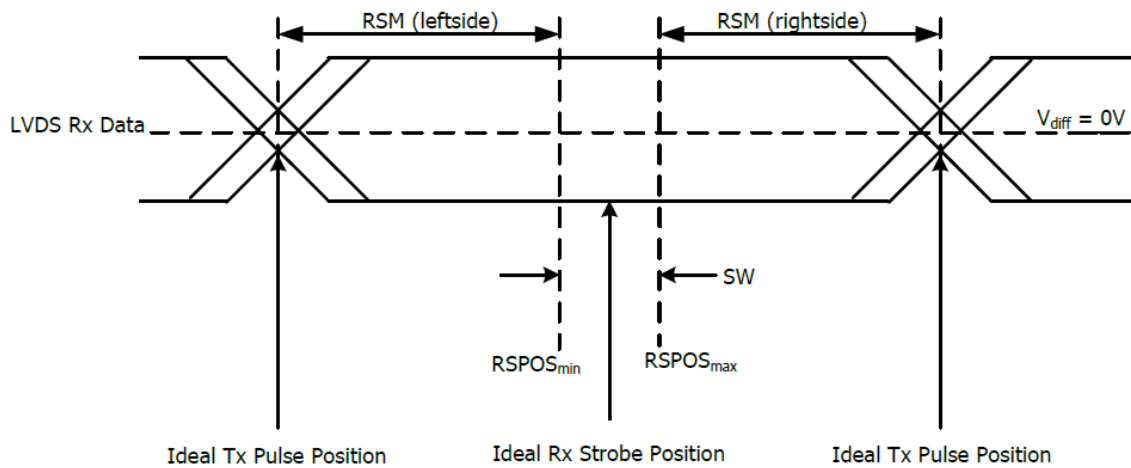

Definitions:

RSM Receiver Skew Margin

RSPOS Receiver Strobe Position

SW Strobe Width (Setup and Hold Time; Internal data sampling window)

6.3 Timing Characteristics

Parameter	Symbol	MIN	Typ	MAX	Unit	Remark
CLK frequency	tclk	71.91	74.25	79.11	MHz	
Horizontal display area	thd	960			tclk	
Horizontal Blanking time	thbt	115	140	165	tclk	
HSYNC period	th	1075	1100	1125	tclk	
Vertical display area	tvd	1080			th	
Vertical Blanking time	tvbt	35	45	92	th	
VSD period	tv	1115	1125	1172	th	
Frame rate	FR	60	60	60	Hz	

6.4 Input Signal Timing Chart

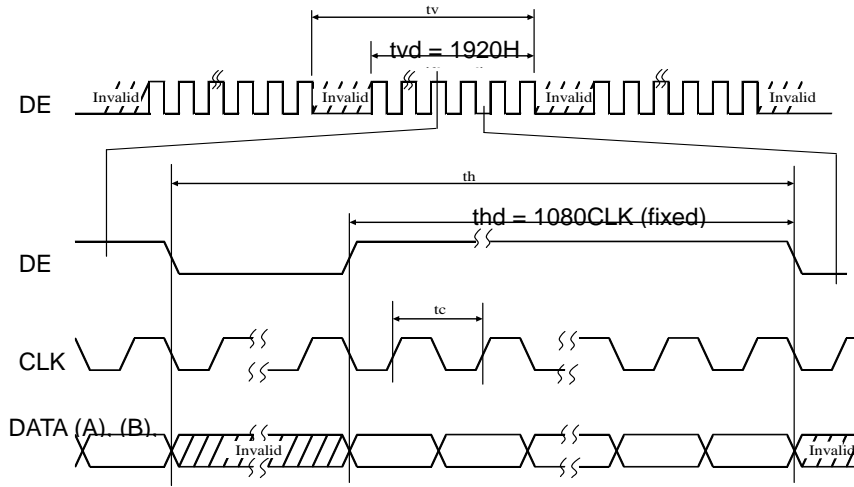

6.5 Input Data Mapping

VESA Data Mapping

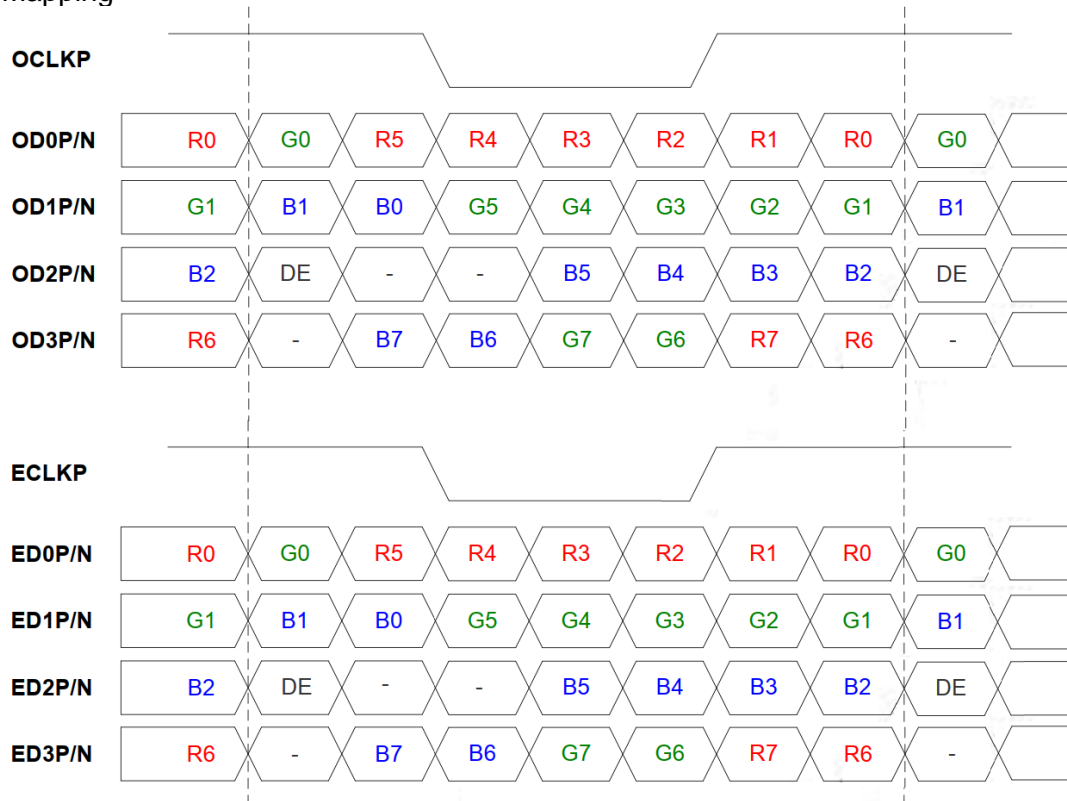

6.6 Recommended LCD Power ON/OFF Sequence

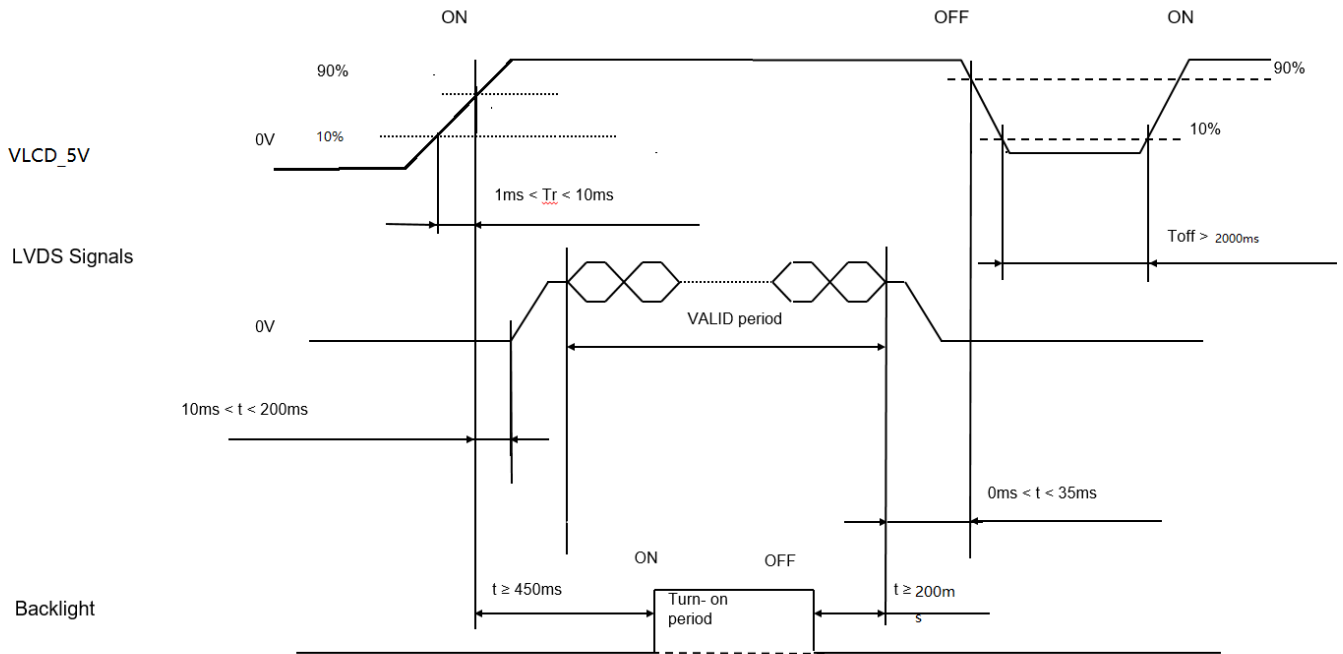

6.7 Backlight power on/off timing

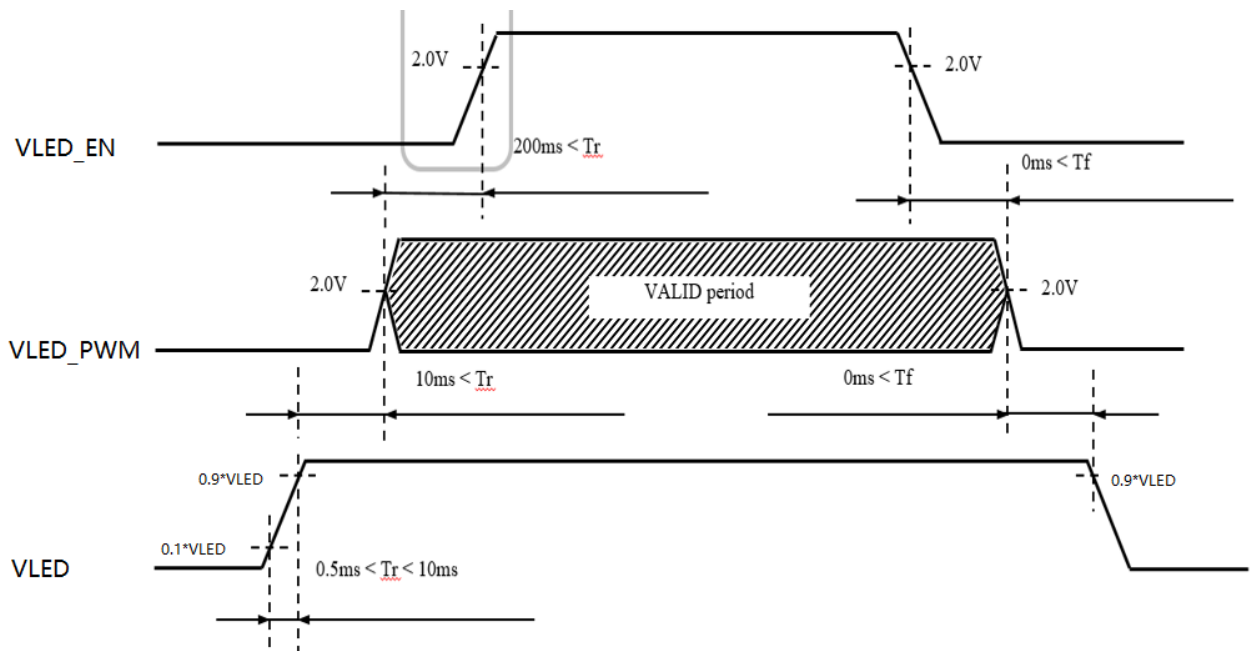

7. Optical Characteristics

Item	Symbol	Condition	Min	Typ	Max	Unit	Remark
View Angles	θT	$CR \geq 10$	80	89		degree	Note2,3
	θB		80	89			
	θL		80	89			
	θR		80	89			
Contrast Ratio	CR	$\theta=0^\circ$	1300	1700			Note 3
Response Time	T_{ON}	25°C		35	45	ms	Note 4
	T_{OFF}						
Chromaticity	White	Backlight is on	x	0.267	0.317	0.367	Note 1,5
			y	0.301	0.351	0.401	
	Red		x	0.593	0.643	0.693	Note 1,5
			y	0.301	0.351	0.401	
	Green		x	0.276	0.326	0.376	Note 1,5
			y	0.575	0.625	0.675	
	Blue		x	0.099	0.149	0.199	Note 1,5
			y	0.004	0.054	0.104	
Uniformity	U		75	85	-	%	Note 6
NTSC	-		67	72		%	Note 5
Luminance	L		425	500		cd/m ²	Note 7

Table 7.1 Optical Parameters

Test Conditions:

1. $I_F = 20$ mA, and the ambient temperature is 25°C.
2. The test systems refer to Note1 and Note2.

Note1: Definition of optical measurement system.

The optical characteristics should be measured in dark room. After 5 Minutes operation, the optical characteristics are measured at the center point of the LCD screen.

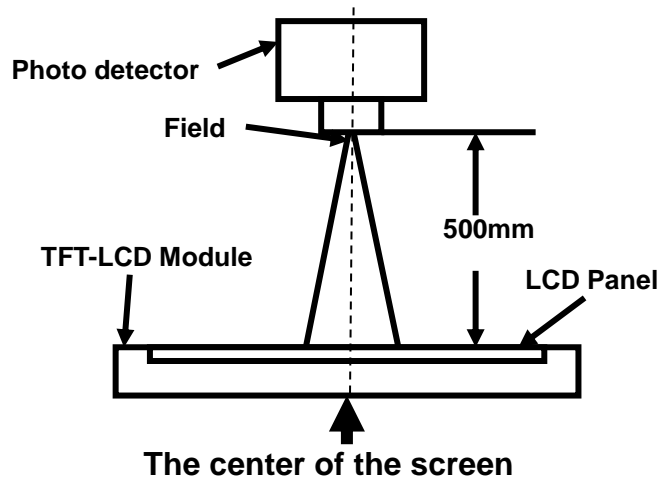

Fig1. Measurement Set Up

Note2: Definition of viewing angle range and measurement system. Viewing angle is measured at the center point of the LCD .

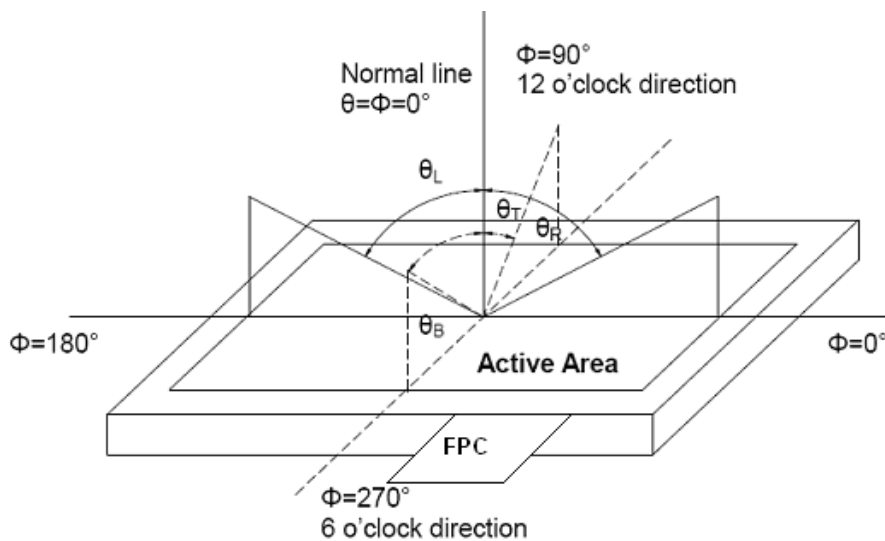

Fig2. Measurement viewing angle

Note3: Definition of contrast ratio

$$\text{Contrast ratio (CR)} = \frac{\text{Luminance measured when LCD is on the "White" state}}{\text{Luminance measured when LCD is on the "Black" state}}$$

Note4: Definition of Response time

For SFT LCM, the response time is defined as the LCD optical switching time interval between “White” state and “Black” state. Rise time (T_r) is the time between photo detector output intensity changed from 10% to 90%. And fall time (T_f) is the time between photo detector output intensity changed from 90% to 10%.

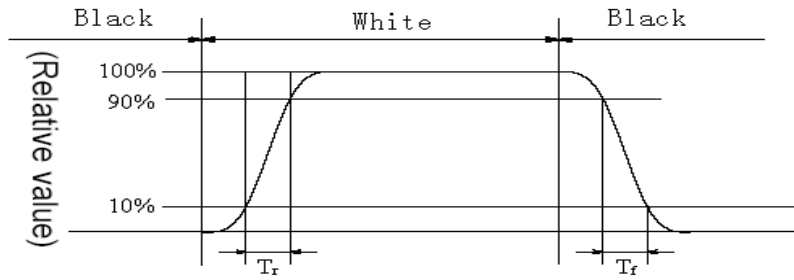

Fig3. Response Time Testing(SFT)

Note5: Definition of color chromaticity (CIE1931)

Color coordinates measured at center point of LCD.

Note6: Definition of Luminance Uniformity

Active area is divided into 9 measuring areas (Refer Fig.5). Every measuring point is placed at the center of each measuring area.

Luminance Uniformity (U) = L_{min} / L_{max}

L_{max} : The measured Maximum luminance of all measurement position.

L_{min} : The measured Minimum luminance of all measurement position.

L-----Active area length; W----- Active area width

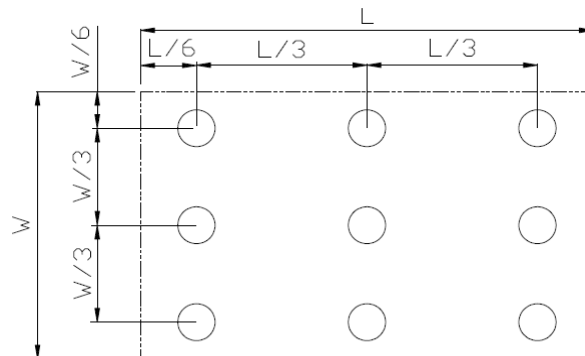

Fig4. Luminance Uniformity Measurement Locations(9 points)

Note7: Definition of Luminance:

Measure the luminance of white state at center point.

8. Reliability Test

No	Test Item	Condition	Remarks
1	High Temperature Operation	+60℃ , 240H	IEC60068-2-1:2007 GB2423.2-2008
2	Low Temperature Operation	-20℃ , 240H	IEC60068-2-1:2007 GB2423.1-2008
3	High Temperature Storage	+60℃ , 240H	IEC60068-2-1:2007 GB2423.2-2008
4	Low Temperature Storage	-20℃ , 240H	IEC60068-2-1:2007 GB2423.1-2008
5	Storage at High Temperature and Humidity(non-operation)	+60℃ , 90%RH , 240H	IEC60068-2-78 :2001 GB/T 2423.3-2016
6	Thermal Shock (non-operation)	-20℃ , 30min~60℃ , 30min , change time : 5min , 100cycle	Start with cold temperature, End with high temperature, IEC60068-2-14:1984, GB/T 2423.22-2012
7	ESD	C=150pF , R=330Ω , 5point/panel Air : ±15kv , 5times ; Contact : ±8kv , 5times ; (Environment : 15℃~35℃ , 30%~60% , 86Kpa~106Kpa)	IEC61000-4-2:2001 GB/T 17626.2-2018
8	Package Vibration	5-20-200HZ , PSD : 0.01-0.01-0.001 Total:0.781g2/HZ,x/y/z 30min)	GB/T 4857.23-2021
9	Package Drop Test	Height: X cm,1 corner, 3edges, 6 surfaces Note : X > 10Kg:60cm ; ≤10Kg:80cm	IEC60068-2-32:1990 GB/T2423.8—1995

Table 8.1 RA test condition

Note1: Temperature is the ambient temperature of sample

Note2: Before cosmetic and function test, the product must have enough recovery time, at least 24 hours at room temperature.

Note3: In the standard condition, there shall be no practical problem that may affect the display function. After the reliability test, the product's function only be guaranteed, but not for all of the cosmetic specification.

Note4: After adding optical bonding, it can be operated with a width of -20℃ to 70℃ , and stored with a width of -30℃ to 80℃.

10. Packing Instruction

No	Item	Model (Material)	Dimensions(mm)	UnitWeight(Kg)	Q'ty	Remark
1	LCM module	P1730FHF1MB00	388.888x225.812x4	0.575	10	
2	Paper card	Corrugated Paper	527x348x265	1.700	1	
3	Dust-proof Bag	PE	700x545x0.05	0.021	1	
4	Carton	Corrugated Paper	544x365x312.5	1.11	1	
5	Paper board	Corrugated Paper	527x348x7	0.130	1	
6	Label	Label	100x52	0.001	1	
7	Tape	Tape	485x330x5	0.001	30	
8	ESD bubble bag	PE	420x386x6	0.012	10	
9	EPE	EPE	524x345x20	0.072	1	
10	Total weight		8.934+/-5% kg			

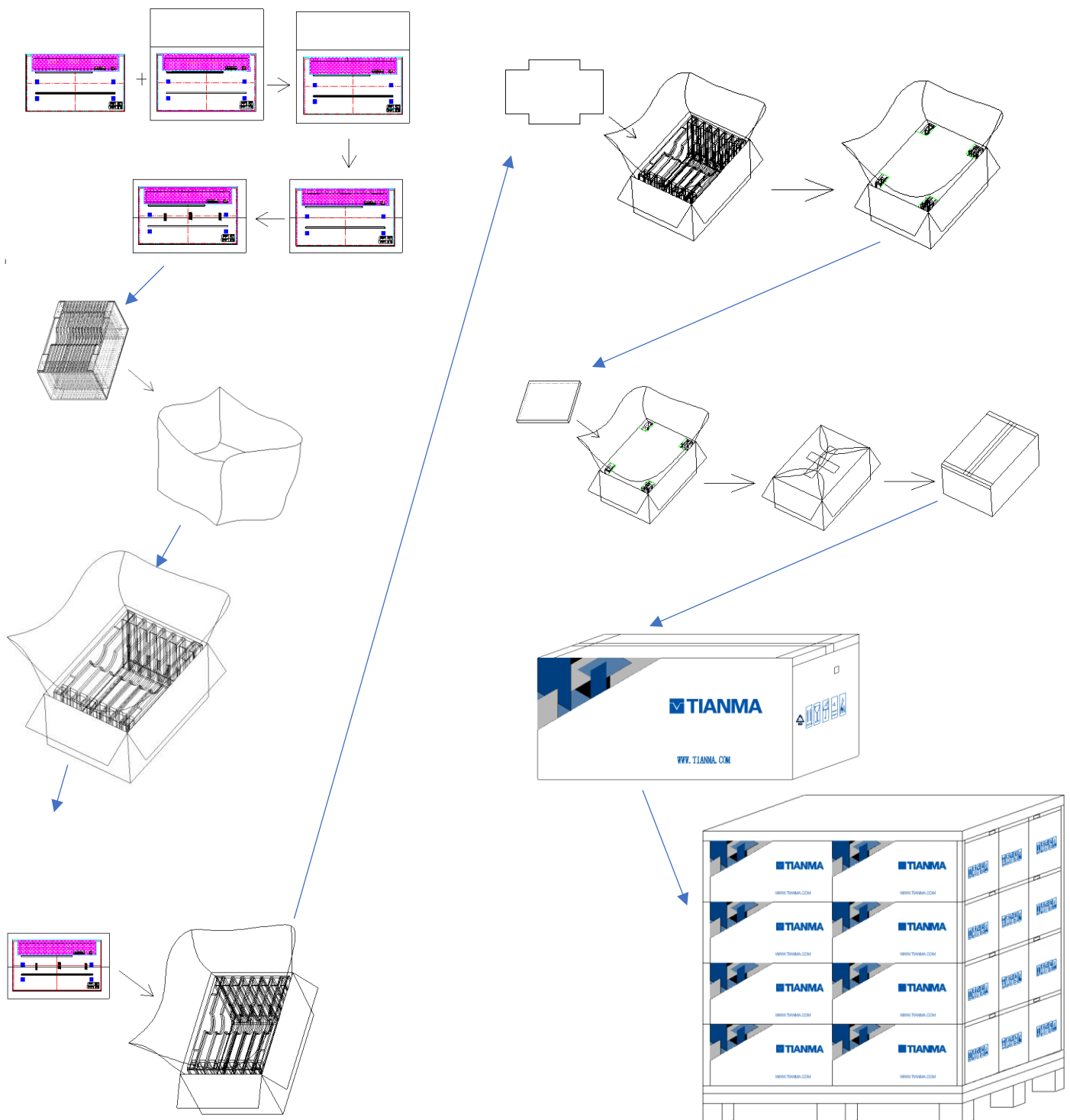

11. Precautions for Use of LCD Modules

11.1 Handling Precautions

- (1) The display panel is made of glass. Do not subject it to mechanical shock by dropping it, etc.
- (2) If the display panel is damaged and the liquid crystal fluid inside it leaks out be sure not to get any in your mouth. If the fluid comes into contact with your skin or clothes promptly wash it off using soap and water.
- (3) Do not apply excessive force to the display surface or the bezel since this may cause the color tone to vary.
- (4) The polarizer covering the display surface of the LCD module is soft and easily scratched. Handle the polarizer carefully.
- (5) If the display surface is contaminated, breathe on the surface and gently wipe it with a soft dry cloth. If it is still not completely clear use a moist cloth with one of the following solvents:
 - Isopropyl alcohol
 - Ethyl alcoholSolvents other than those mentioned above may damage the polarizer. Specifically, do not use the following:
 - Water
 - Ketone
 - Aromatic solvents
- (6) Do not disassemble the LCD Module.
- (7) If powered off, do not apply the input signals.
- (8) To prevent destruction of the module by static electricity, be careful to maintain an optimum work environment.
- (9) Be sure to ground your body when handling the LCD Modules.
- (10) Tools used for assembly, must be properly grounded.
- (11) To reduce the amount of static electricity generated, do not conduct assembly or other work under very low humidity conditions.
- (12) The LCD Module is covered with a film to protect the display surface, remove film slowly under the ionizer.

11.2 Storage precautions

- (1) When storing the LCD modules avoid exposure to direct sunlight or to the light of fluorescent lamps.
- (2) The LCD modules should be stored within the rated storage temperature range. The recommend condition is: Temperature: 0 ~ 35 °C at normal humidity.
- (3) The LCD modules should be stored in a room without acid, alkali or other harmful gas.

11.3 Transportation Precautions

The LCD modules should not be dropped or subject to violent mechanical shock during transportation. Also they should avoid excessive pressure, water, high humidity and direct sunlight.

11.4 Screen saver Precautions

Not display the fixed pattern for a long time. Use a screen saver, if the fixed pattern is displayed on the screen

11.5 Safety Precautions

- (1) When you waste damaged or unnecessary LCDs, it is recommended to crush LCDs into pieces and wash them off with solvents such as acetone and ethanol, which should later be burned
- (2) Be sure to turn off the power supply when inserting or disconnecting the LED backlight cable.
- (3) LED driver should be designed to limit or stop its function when over current is detected on the LED.