





# CONTENTS

<b>1. SUMMARY</b> .....	<b>1</b>
1.1 General Description.....	1
1.2 Features.....	1
<b>2. GENERAL SPECIFICATIONS</b> .....	<b>2</b>
<b>3. INPUT / OUTPUT TERMINALS</b> .....	<b>3</b>
3.1 CN1 Pin assignment (LCD Interface).....	3
3.2 CN2 Pin assignment (Back Light).....	3
<b>4. ABSOLUTE MAXIMUM RATINGS</b> .....	<b>5</b>
<b>5. ELECTRICAL CHARACTERISTICS</b> .....	<b>6</b>
5.1 DC Characteristics for Panel Driving.....	6
5.2 DC Characteristics for Backlight Driving.....	6
5.3 Fuse.....	7
5.4 POWER SUPPLY VOLTAGE SEQUENCE.....	7
5.5 LCD Module Block Diagram .....	9
<b>6. TIMING CHARACTERISTICS</b> .....	<b>11</b>
6.1 Timing characteristics.....	11
<b>7. OPTICAL CHARACTERISTICS</b> .....	<b>14</b>
<b>8. RELIABILITY TEST</b> .....	<b>17</b>
<b>9. MECHANICAL DRAWING</b> .....	<b>18</b>
<b>10. PACKING INSTRUCTION</b> .....	<b>19</b>
<b>11. PRECAUTIONS FOR USE OF LCD MODULES</b> .....	<b>20</b>
11.1 Handling Precautions.....	20
11.2 Storage precautions.....	20
11.3 Transportation Precautions .....	20
11.4 Screen saver Precautions.....	20
11.5 Safety Precautions .....	20

## 1. Summary

### 1.1 General Description

This is a 12.1 inch a-Si TFT-LCD module with Normal- Black technology. It is composed of a TFT-LCD panel, a driver circuit, PCB, and a LED backlight unit.

### 1.2 Features

- Ultra-wide viewing angle
- High luminance
- Wide temperature range
- Interface: LVDS 1port
  
- Acquisition product for UL62368-1/CSA C22.2 No.62368-1-03
- Compliant with the European RoHS Directive (2011/65/EU) and Delegated Directive (2015/863/EU, Amending Annex II of 2011/65/EU)

## 2. General Specifications

	Feature	Spec	Unit
<b>Display Spec</b>	Size	12.1 inches	
	Resolution	1280(RGB)x800	
	Pixel Pitch	0.204x0.204	mm
	TFT Active Area	261.12 x163.2	mm
	Technology Type	a-Si	
	Pixel Configuration	R.G.B Vertical Stripe	
	Display Mode	SFT, Normally Black	
	Surface Treatment	Anti-Glare	
	Viewing Direction	All direction	
	Gray Scale Inversion Direction	NA	
<b>Mechanical Characteristics</b>	LCM (W x H x D)	277.7x 180.6x8.7	mm
	Weight	TBD	g
<b>Optical Characteristics</b>	Luminance	1100	cd/m <sup>2</sup>
	Contrast Ratio	1000:1	
	NTSC	40	%
	Viewing Angle	88/88/88/88	degree
<b>Electrical Characteristics</b>	Interface	LVDS 1port	
	Color Depth	16.7 Million	color
	Power Consumption	LCD:TBD Backlight:TBD	mW

**Table 2.1 General TFT Specifications**

### 3. Input / Output Terminals

#### 3.1 CN1 Pin assignment (LCD Interface)

Connector Information	
LCD Module connector	FI-SE20P-HFE
Matching connector	FI-S20S

Table 3.1.1 Connector information

No	Symbol	I/O	Description	Comment
1	D3+	I	Positive(+) LVDS differential data input	
2	D3-	I	Negative(-) LVDS differential data input	
3	N.C.	N	No connection	
4	N.C.	N	No connection	
5	GND	P	Power ground	
6	CLK+	I	Clock Signal(+)	
7	CLK-	I	Clock Signal(-)	
8	GND	P	Ground	
9	D2+	I	Positive(+) LVDS differential data input	
10	D2-	I	Negative(-) LVDS differential data input	
11	GND	P	Power ground	
12	D1+	I	Positive(+) LVDS differential data input	
13	D1-	I	Negative(-) LVDS differential data input	
14	GND	P	Power ground	
15	D0+	I	Positive(+) LVDS differential data input	
16	D0-	I	Negative(-) LVDS differential data input	
17	GND	P	Power ground	
18	N.C.	N	No connection	
19	VCC	P	Power supply +3.3V	
20	VCC	P	Power supply +3.3V	

Table 3.1.2 Pin Assignment for LCD Interface

Note1: I/O definition: I---Input, O---Output, P---Power/Ground, N---No connection

Note2: All of the GND pins should be connected to the system ground.

Note3: Twist pair wires with 100Ω (Characteristic impedance) should be used between LCD panel signal processing board and LVDS transmitter.

#### 3.2 CN2 Pin assignment (Back Light)

Connector Information	
LCD Module connector	SM10B-SHLS-TF (LF) (SN)

Matching connector	: SHLP-10V-S-B
--------------------	----------------

**Table 3.2.1 Connector information**

No	Symbol	I/O	Description	Wire Color
1	A1	P	LED driving anode (+)	1
2	A2	P	LED driving anode (+)	2
3	A3	P	LED driving anode (+)	3
4	A4	P	LED driving anode (+)	4
5	NC	NC	keep this pin open	5
6	NC	NC	keep this pin open	6
7	K1	P	LED driving cathode (-)	7
8	K2	P	LED driving cathode (-)	8
9	K3	P	LED driving cathode (-)	9
10	K4	P	LED driving cathode (-)	10

**Table 3.2.2 Pin Assignment for Back Light Interface**

Note1: I/O definition: I---Input, O---Output, P---Power/Ground, N---No connection

#### 4. Absolute Maximum Ratings

Item	Symbol	MIN	MAX	Unit	Remark
Power Voltage	VCC	-0.3	4.0	V	Note1
Input voltage	V <sub>IN</sub>	-0.3	4.0	V	
Operating Temperature	Top	-30	80	°C	
Storage Temperature	Tst	-30	80	°C	
Relative Humidity Note2	RH	--	≤95	%	Ta≤40°C
		--	≤85	%	40°C < Ta≤50°C
		--	≤55	%	50°C < Ta≤60°C
		--	≤36	%	60°C < Ta≤70°C
		--	≤24	%	70°C < Ta≤80°C
Absolute Humidity	AH	--	≤70	g/m <sup>3</sup>	Ta > 70°C

**Table 4.1 Absolute Maximum Ratings**

Note1: Input voltage include all in put data.

Note2: Ta means the ambient temperature. It is necessary to limit the relative humidity to the specified temperature range. Condensation on the module is not allowed.

Note3: The absolute maximum rating values of this product are not allowed to be exceeded at any times. A module should be used with any of the absolute maximum ratings exceeded, the characteristics of the module may not be recovered, or in an extreme condition, the module may be permanently destroyed

## 5. Electrical Characteristics

### 5.1 DC Characteristics for Panel Driving

Parameter	Symbol	min.	typ.	max.	Unit	Remarks
Power supply voltage	VCC	3.2	3.3	3.4	V	-
Power supply current	ICC	-	TBD Note2	TBD Note3	mA	at VCC= 3.3V
Permissible ripple voltage	VRP	-	-	100	mVp-p	for VCC Note4,Note5,Note6
Differential input threshold voltage	High	VTH	-	+100	mV	at VCM= 1.2V Note7, Note8
	Low	VTL	-100	-	mV	
Input Differential Voltage	VID	100	-	600	mV	-
Differential Input Common Mode Voltage	VCM	0.7	-	1.6	V	-
Terminating resistance	RT	-	100	-	Ω	-

Table 5.1.1 Operating Voltages

Note1: When designing of the power supply, take the measures for the prevention of surge voltage.

Note2: Checkered flag pattern [by IEC 61747-6]

Note3: Pattern for maximum current

Note4: This product works even if the ripple voltage levels are over the permissible values, but there might be noise on the display image.

Note5: The permissible ripple voltage includes spike noise.

Note6: The load variation influence does not include.

Note7: Common mode voltage for LVDS receiver

Note8: DC characteristics (LVDS receiver part)

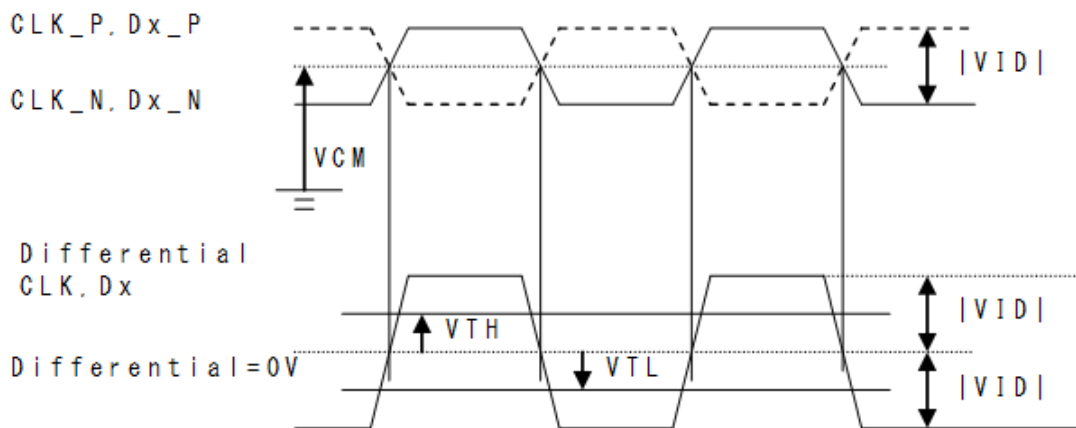

$CLK\_P, CLK\_N$   
 $Dx\_P, Dx\_N: x = 0, 1, 2, 3$   
 $|VID| = |**\_P - **\_N|$   
 $VCM = (**\_P + **\_N) / 2$   
 $P: +, N: -$   
 $** : CLK \text{ or } Dx$

### 5.2 DC Characteristics for Backlight Driving

Parameter	Symbol	min.	typ.	max.	Unit	Remarks
Forward current	IL	-	TBD	(65)	mA	-

Forward Voltage	VL	TBD	TBD	TBD	Ta= +25°C , at IL= (60) mA/One circuit
		TBD	-	-	Ta= +80°C , at IL= (60) mA/One circuit
		-	-	TBD	Ta= -30°C , at IL= (60)mA/One circuit
		-	-	TBD	Ta= -30°C , at IL= (65)mA/One circuit

Table 5.2.1 LED Backlight Characteristics

Note1: Please drive with constant current.

Note2: The above specifications are for one LED circuit of the backlight.

Note3: The Luminance uniformity may be changed depending on the current variation between 4 circuits.

It is recommended that the current value difference among the circuits be less than 5%.

### 5.3 Fuse

Parameter	Fuse		Rating	Fusing current	Remarks
	Type	Supplier			
VCC	FCC16202AB	KAMAYA ELECTRIC CO.,LTD	2.0A	4.0A 5 seconds maximum	Note1
			36V		

Table 5.3.1 Fuse

Note1: The power supply's rated current must be more than the fusing current. If it is less than the fusing current, the fuse may not blow in a short time, and then nasty smell, smoke and so on may occur.

## 5.4 POWER SUPPLY VOLTAGE SEQUENCE

### 5.4.1 LCD panel signal processing board

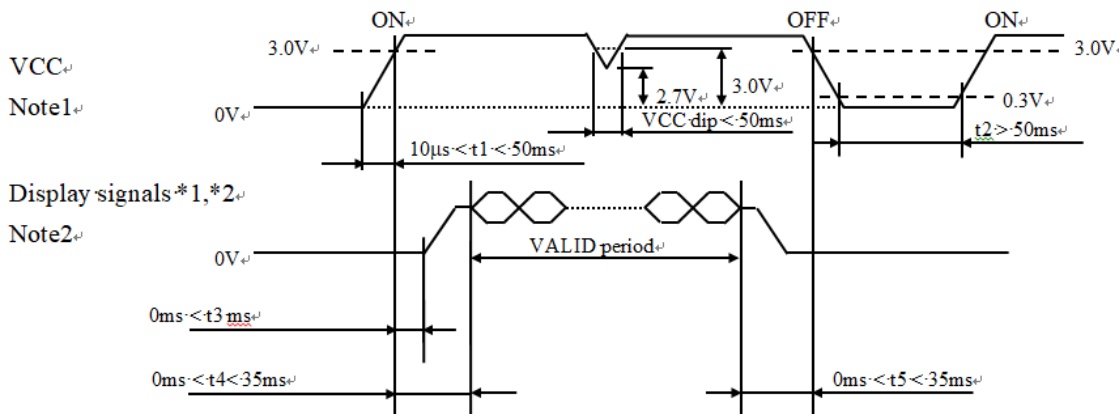

\*1 D0+/-, D1+/-, D2+/-, D3+/-, CLK+/-

\*2 These signals should be measured at the terminal of 100Ω resistance.

Note1: If there is a voltage variation (voltage drop) at the rising edge of VCC below 3.0V, there is a possibility that a product does not work due to a protection circuit.

Note2: Display signals (D0+/-, D1+/-, D2+/-, D3+/- and CLK+/-) must be set to Low or High-impedance, except the VALID period (See above sequence diagram), in order to avoid the circuitry damage.

If some of display signal of this product are cut while this product is working, even if the signal input to it once again, it might not work normally. If a customer stops the display signals, VCC also must be shut down.

### 5.4.2 LED driver

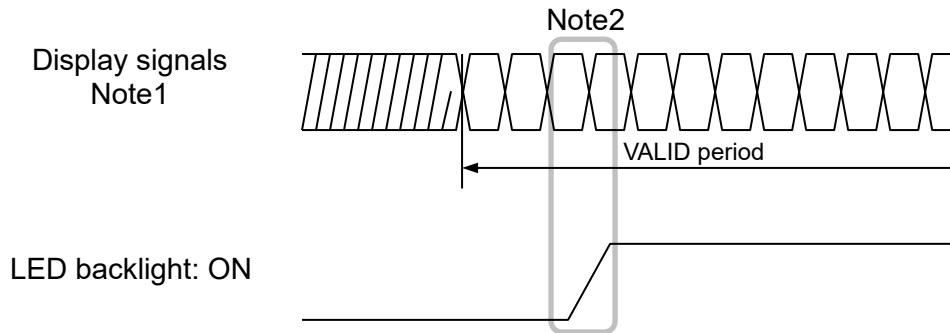

Note1: These are the display signals for LCD panel signal processing board.

Note2: The backlight should be turned on within the VALID period of display signals, in order to avoid unstable data display.

5.5 LCD Module Block Diagram

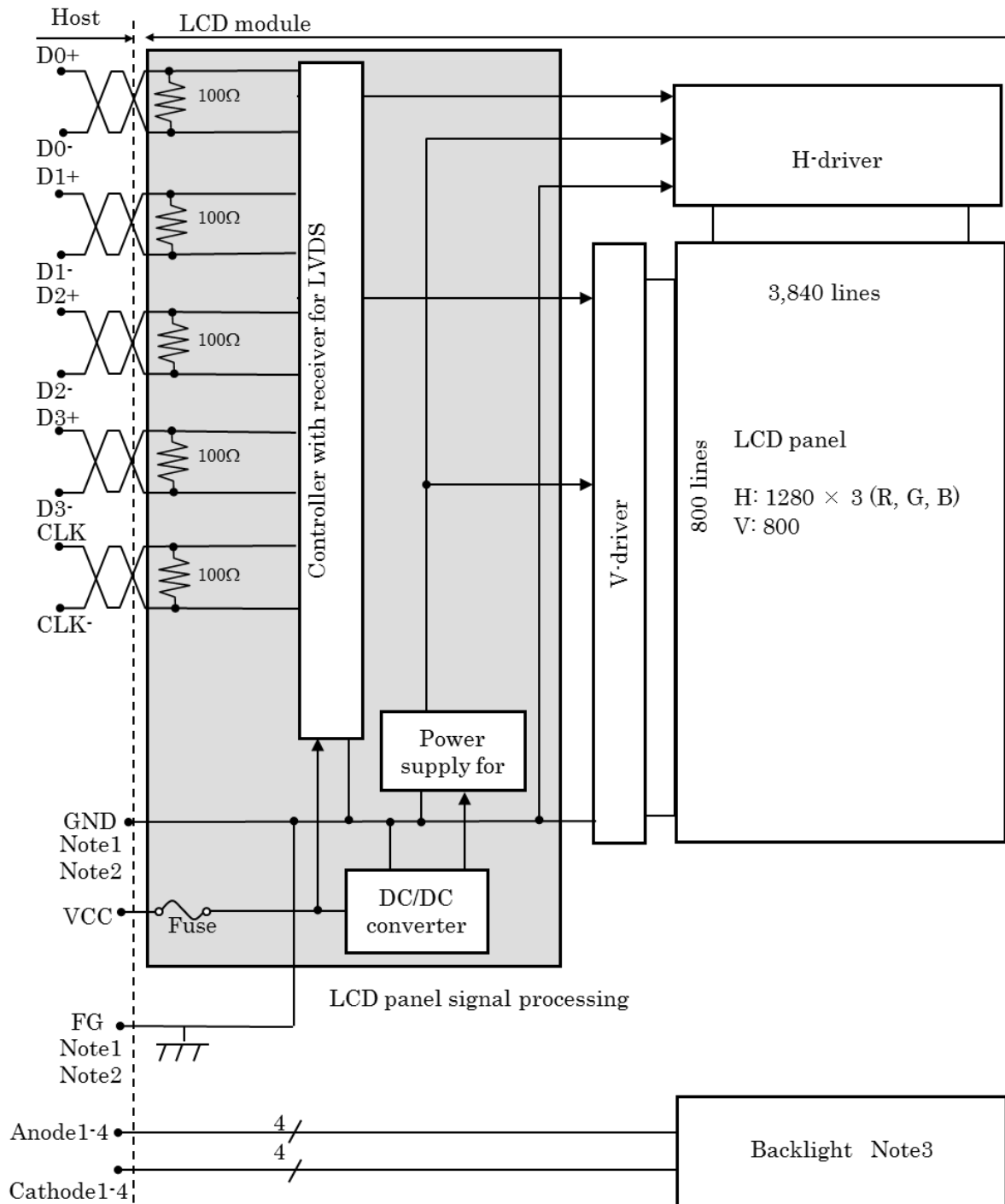

Figure 5.5.1 LCD Module Block Diagram

Note1: Relation between GND (Signal ground) and FG (Frame ground) in the LCD module is as follows.

GND- FG	Connected
---------	-----------

Note2: GND and FG must to be connected to customer equipment's ground, and it is recommended that these grounds to be connected together in customer equipment.

Note3: Backlight in detail

Backlight

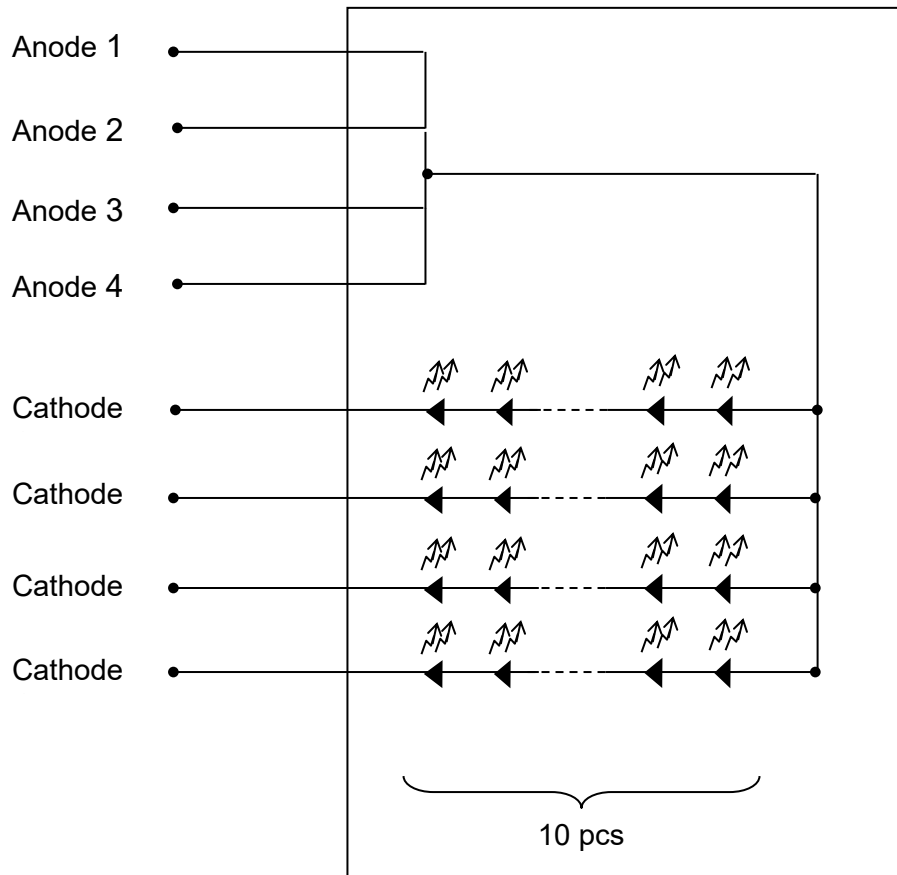

## 6. Timing Characteristics

### 6.1 Timing characteristics

7 (Note1, Note2, Note3)

Parameter		Symbol	min.	typ.	max.	Unit	Remarks	
CLK	Frequency	1/tc	67.0	71.0	75.0	MHz	14.085 ns (typ.)	
DATA	CLK-DATA	Setup time	-	-			ns	-
		Hold time	-				ns	
	Rise time, Fall time	-	ns					
DE	Horizontal	Cycle	th	17.20	20.28	21.49	μs	49.306 kHz (typ.)
				1,290	1,440	-	CLK	
		Display period	thd	1,280			CLK	-
	Vertical (One frame)	Cycle	tv	14.16	16.69	17.69	ms	59.91 Hz (typ.)
				-	823	-	H	
Display period		tvd	800			H	-	
	Hold time	-				ns		

### 6.2 Input signal timing chart

Horizontal timing

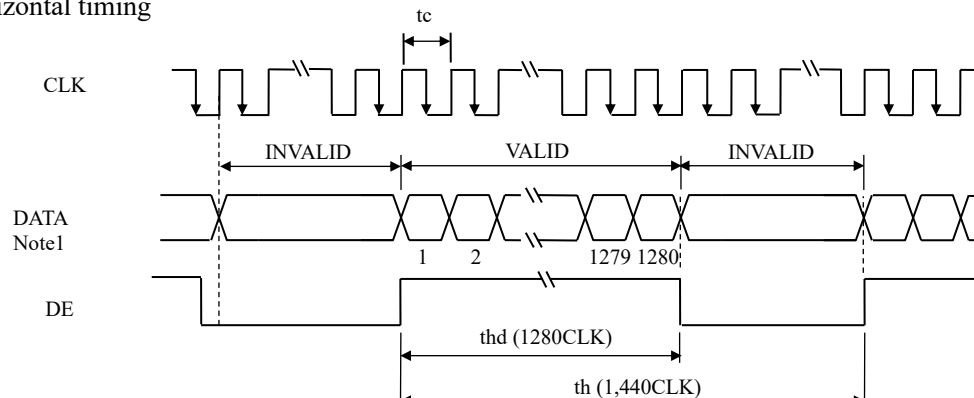

Vertical timing

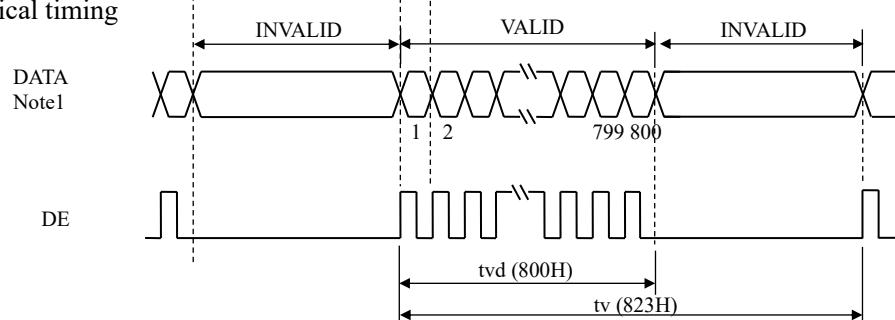

• Horizontal signal

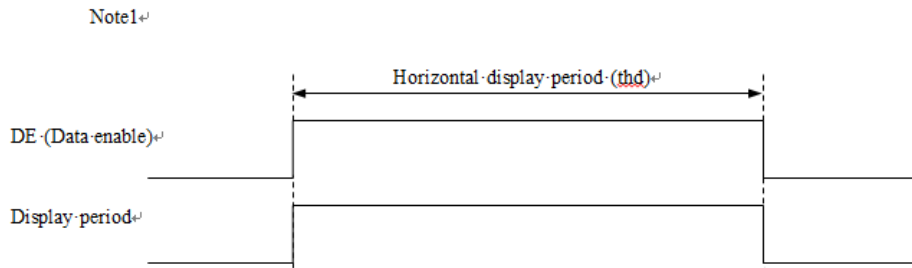

• Vertical signal

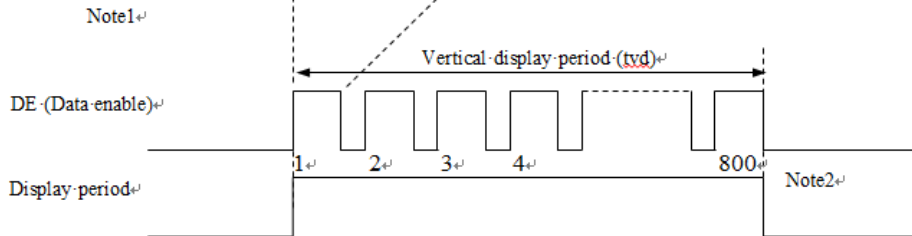

6.3 LVDS Rx AC SPEC

Symbol	Parameter	min.	typ.	max.	Units
t <sub>RCIP</sub>	CKy_+ Period	13.34	-	14.92	ns
t <sub>RCIH</sub>	CKy_+ High pulse width	-	$\frac{4}{7} t_{RCIP}$	-	ns
t <sub>RCIL</sub>	CKy_+ Low pulse width	-	$\frac{3}{7} t_{RCIP}$	-	ns
t <sub>RMG</sub>	Receiver Data Input Margin	(-0.4)	-	(0.4)	ns
t <sub>RIP1</sub>	Input Data Position0	- t <sub>RMG</sub>	0.0	+ t <sub>RMG</sub>	ns
t <sub>RIP0</sub>	Input Data Position1	$\frac{t_{RCIP}}{7} -  t_{RMG} $	$\frac{t_{RCIP}}{7}$	$\frac{t_{RCIP}}{7} +  t_{RMG} $	ns
t <sub>RIP6</sub>	Input Data Position2	$2 \frac{t_{RCIP}}{7} -  t_{RMG} $	$2 \frac{t_{RCIP}}{7}$	$2 \frac{t_{RCIP}}{7} +  t_{RMG} $	ns
t <sub>RIP5</sub>	Input Data Position3	$3 \frac{t_{RCIP}}{7} -  t_{RMG} $	$3 \frac{t_{RCIP}}{7}$	$3 \frac{t_{RCIP}}{7} +  t_{RMG} $	ns
t <sub>RIP4</sub>	Input Data Position4	$4 \frac{t_{RCIP}}{7} -  t_{RMG} $	$4 \frac{t_{RCIP}}{7}$	$4 \frac{t_{RCIP}}{7} +  t_{RMG} $	ns
t <sub>RIP3</sub>	Input Data Position5	$5 \frac{t_{RCIP}}{7} -  t_{RMG} $	$5 \frac{t_{RCIP}}{7}$	$5 \frac{t_{RCIP}}{7} +  t_{RMG} $	ns
t <sub>RIP2</sub>	Input Data Position6	$6 \frac{t_{RCIP}}{7} -  t_{RMG} $	$6 \frac{t_{RCIP}}{7}$	$6 \frac{t_{RCIP}}{7} +  t_{RMG} $	ns

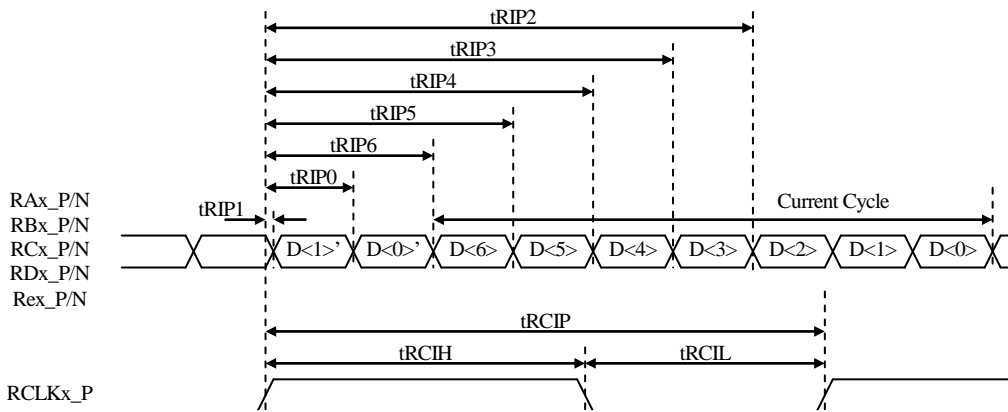

### 6.4 Input data mapping

Input data signal: 8-bit

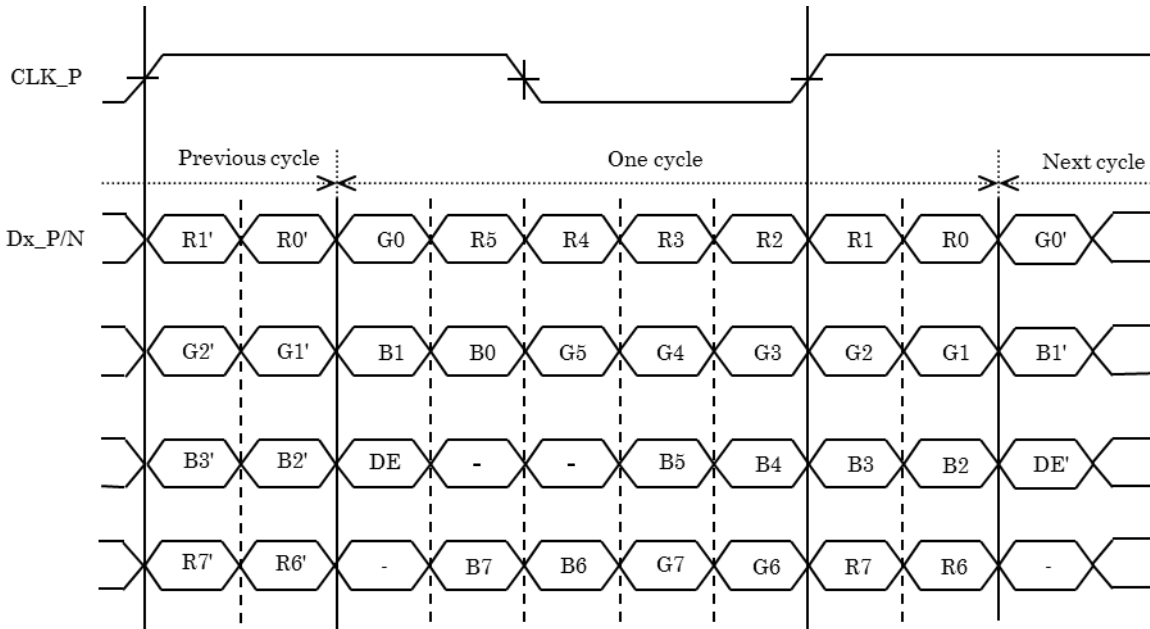

Note1: LSB (Least Significant Bit) – R0, G0, B0 MSB (Most Significant Bit) – R7, G7, B7

Note2: Twist pair wires with 100Ω (Characteristic impedance) should be used between LCD panel signal processing board and LVDS transmitter.

Note3: Dx\_P/N: x = 0,1,2,3 (P: +, N: -)

## 7. Optical Characteristics

Item	Symbol	Condition	Min	Typ	Max	Unit	Remark
View Angles	$\theta T$	$CR \geq 10$	70	88		degree	Note2,3
	$\theta B$		70	88			
	$\theta L$		70	88			
	$\theta R$		70	88			
Contrast Ratio	CR	$\theta=0^\circ$	700	1000			Note 3
Response Time	$T_{ON}$	25°C		25	40	ms	Note 4
	$T_{OFF}$						
Chromaticity	White	x	Backlight is on	0.263	0.313	0.363	Note 1,5
		y		0.279	0.329	0.379	
	Red	x		-	(0.572)	-	Note 1,5
		y		-	(0.339)	-	
	Green	x		-	(0.350)	-	Note 1,5
		y		-	(0.556)	-	
	Blue	x		-	(0.163)	-	Note 1,5
		y		-	(0.139)	-	
Uniformity	U		70	75		%	Note 6
NTSC	-		35	40		%	Note 5
Luminance	L		800	1100		cd/m <sup>2</sup>	Note 7

Table 7.1 Optical Parameters

Test Conditions:

1.  $I_F = 160$  mA, and the ambient temperature is 25°C.
2. The test systems refer to Note1 and Note2.

Note1: Definition of optical measurement system.

The optical characteristics should be measured in dark room. After 5 Minutes operation, the optical characteristics are measured at the center point of the LCD screen.

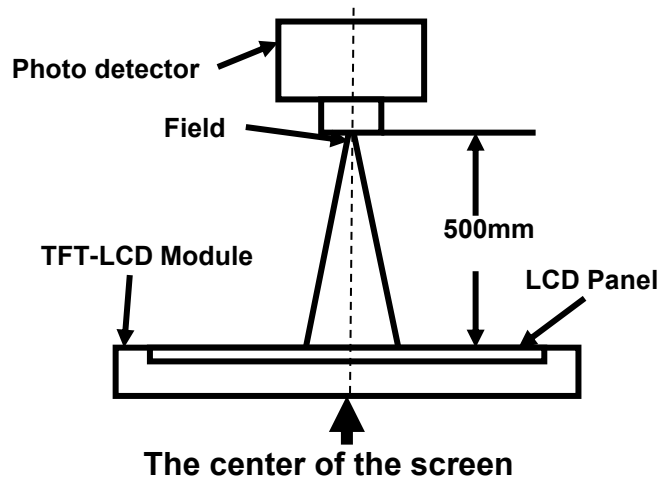

Fig1. Measurement Set Up

Note2: Definition of viewing angle range and measurement system. Viewing angle is measured at the center point of the LCD .

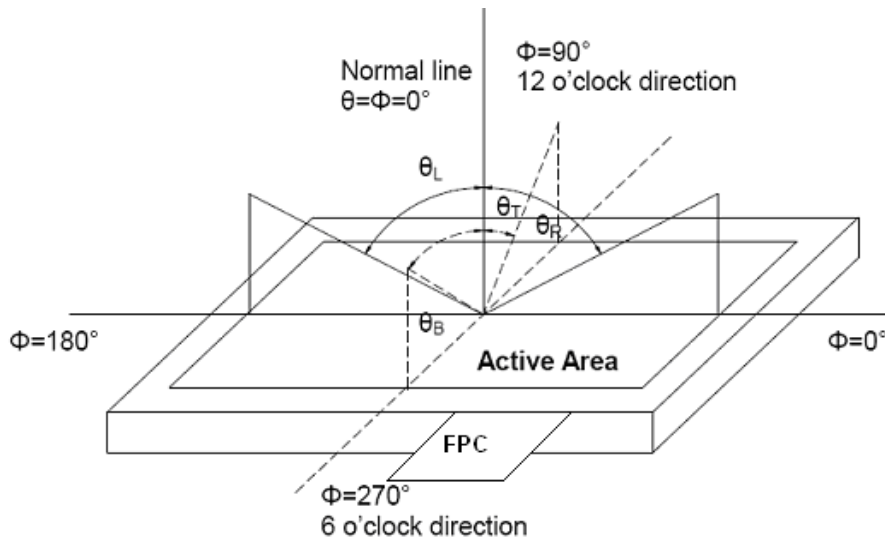

Fig2. Measurement viewing angle

Note3: Definition of contrast ratio

$$\text{Contrast ratio (CR)} = \frac{\text{Luminance measured when LCD is on the "White" state}}{\text{Luminance measured when LCD is on the "Black" state}}$$

Note4: Definition of Response time

For SFT LCM, the response time is defined as the LCD optical switching time interval between “White” state and “Black” state. Rise time ( $T_r$ ) is the time between photo detector output intensity changed from 10% to 90%. And fall time ( $T_f$ ) is the time between photo detector output intensity changed from 90% to 10%.

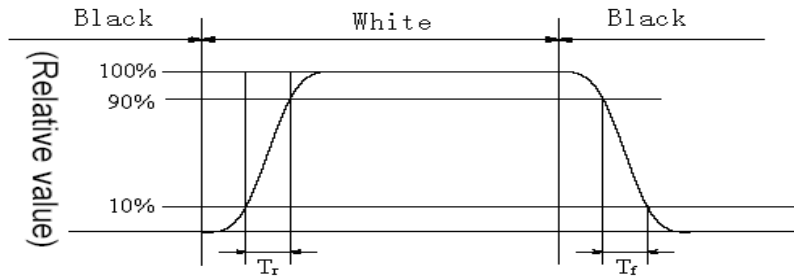

**Fig3. Response Time Testing(SFT)**

Note5: Definition of color chromaticity (CIE1931)

Color coordinates measured at center point of LCD.

Note6: Definition of Luminance Uniformity

Active area is divided into 9 measuring areas (Refer Fig.5). Every measuring point is placed at the center of each measuring area.

Luminance Uniformity (U) =  $L_{min} / L_{max}$

$L_{max}$ : The measured Maximum luminance of all measurement position.

$L_{min}$ : The measured Minimum luminance of all measurement position.

L-----Active area length; W----- Active area width

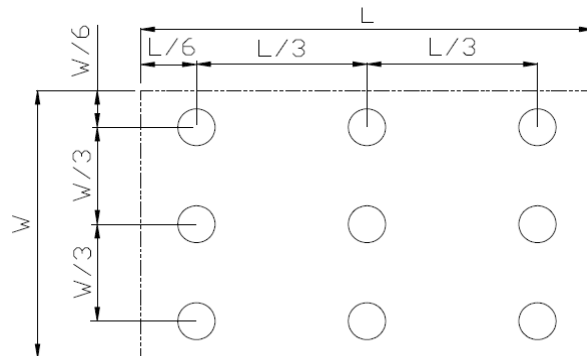

**Fig5. Luminance Uniformity Measurement Locations(9 points)**

Note7: Definition of Luminance:

Measure the luminance of white state at center point.

## 8. Reliability Test

No	Test Item	Condition	Remarks
1	High Temperature Operation	+80℃ , 240H	IEC60068-2-1:2007 GB2423.2-2008
2	Low Temperature Operation	-30℃ , 240H	IEC60068-2-1:2007 GB2423.1-2008
3	High Temperature Storage	+80℃ , 240H	IEC60068-2-1:2007 GB2423.2-2008
4	Low Temperature Storage	-30℃ , 240H	IEC60068-2-1:2007 GB2423.1-2008
5	Storage at High Temperature and Humidity(Operation)	+60℃ , 90%RH , 240H	IEC60068-2-78 :2001 GB/T2423.3—2006
6	Thermal Shock (non-operation)	-30℃ , 30min~80℃ , 30min , change time : 5min , 100cycle	Start with cold temperature, End with high temperature, IEC60068-2-14:1984,GB2423.22-2002
7	ESD	(1)150pF, 150Ω, ± 15kV (2)9 places on a panel surface (3)10 times each place at 1 sec interval ; ( Environment : 15℃~35℃ , 30%~60% , 86Kpa~106Kpa )	IEC61000-4-2:2001 GB/T17626.2-2006
8	Package Vibration	5-20-200HZ , PSD : 0.01-0.01-0.001 Total:0.781g <sup>2</sup> /HZ,x/y/z 30min )	
9	Vibration 1 (Non operation)	(1) Perform the test in accordance with IEC 60068-2-64, random vibration. (2) 32 h for each plane of the DUT. (3)The angle between the DUT and platform is 45° Note3,Note4	
10	Vibration 2 (Non operation)	(1)5 to 100Hz, 19.6m/s <sup>2</sup> (2)1 minute/cycle (3)X, Y, Z directions (4)120 times each direction	
11	Mechanical shock (Non operation)	(1)539m/s <sup>2</sup> , 11ms (2)± X, ± Y, ± Z directions (3)5 times each direction	
12	Package Drop Test	Height: X cm,1 corner, 3edges, 6 surfaces Note : X > 10Kg:60cm ; ≤10Kg:80cm	IEC60068-2-32:1990 GB/T2423.8—1995

**Table 8.1 RA test condition**

Note1: Temperature is the ambient temperature of sample

Note2: Before cosmetic and function test, the product must have enough recovery time, at least 2 hours at room temperature.

Note3: In the standard condition, there shall be no practical problem that may affect the display function. After the reliability test, the product's function only be guaranteed, but not for all of the cosmetic specification.

9. Mechanical Drawing

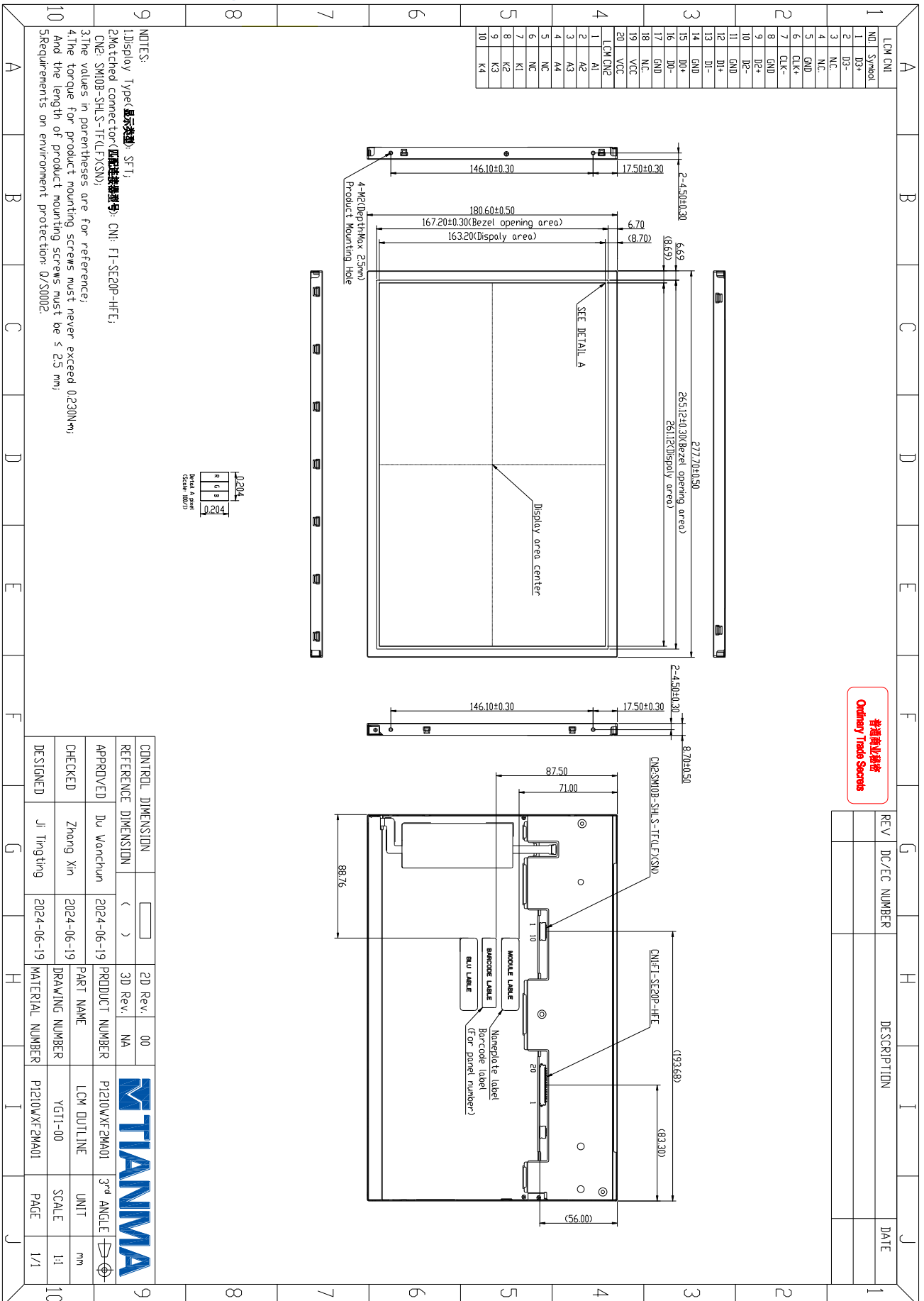

普通商业结构  
Ordinary Trade Structure

## 10. Packing Instruction

No	Item	Model (Material)	Dimensions(m m)	Unit Weight(Kg)	Q'ty	Remark
1	LCM module					
2	Tray					
3	Dust Proof Bag					
4	BOX					
5	Carton					
6	Total weight					

TBD

## 11. Precautions for Use of LCD Modules

### 11.1 Handling Precautions

- (1) The display panel is made of glass. Do not subject it to mechanical shock by dropping it, etc.
- (2) If the display panel is damaged and the liquid crystal fluid inside it leaks out be sure not to get any in your mouth. If the fluid comes into contact with your skin or clothes promptly wash it off using soap and water.
- (3) Do not apply excessive force to the display surface or the bezel since this may cause the color tone to vary.
- (4) The polarizer covering the display surface of the LCD module is soft and easily scratched. Handle the polarizer carefully.
- (5) If the display surface is contaminated, breathe on the surface and gently wipe it with a soft dry cloth. If it is still not completely clear use a moist cloth with one of the following solvents:
  - Isopropyl alcohol
  - Ethyl alcoholSolvents other than those mentioned above may damage the polarizer. Specifically, do not use the following:
  - Water
  - Ketone
  - Aromatic solvents
- (6) Do not disassemble the LCD Module.
- (7) If powered off, do not apply the input signals.
- (8) To prevent destruction of the module by static electricity, be careful to maintain an optimum work environment.
- (9) Be sure to ground your body when handling the LCD Modules.
- (10) Tools used for assembly, must be properly grounded.
- (11) To reduce the amount of static electricity generated, do not conduct assembly or other work under very low humidity conditions.
- (12) The LCD Module is covered with a film to protect the display surface, remove film slowly under the ionizer.

### 11.2 Storage precautions

- (1) When storing the LCD modules avoid exposure to direct sunlight or to the light of fluorescent lamps.
- (2) The LCD modules should be stored within the rated storage temperature range. The recommend condition is: Temperature: 0 ~ 35 °C at normal humidity.
- (3) The LCD modules should be stored in a room without acid, alkali or other harmful gas.

### 11.3 Transportation Precautions

The LCD modules should not be dropped or subject to violent mechanical shock during transportation. Also they should avoid excessive pressure, water, high humidity and direct sunlight.

### 11.4 Screen saver Precautions

Not display the fixed pattern for a long time. Use a screen saver, if the fixed pattern is displayed on the screen

### 11.5 Safety Precautions

- (1) When you waste damaged or unnecessary LCDs, it is recommended to crush LCDs into pieces and wash them off with solvents such as acetone and ethanol, which should later be burned
- (2) Be sure to turn off the power supply when inserting or disconnecting the LED backlight cable.
- (3) LED driver should be designed to limit or stop its function when over current is detected on the LED.