





## CONTENTS

<b>1. SUMMARY .....</b>	<b>3</b>
1.1 General Description.....	3
1.2 Features .....	3
<b>2. GENERAL SPECIFICATIONS.....</b>	<b>4</b>
<b>3. INPUT / OUTPUT TERMINALS.....</b>	<b>5</b>
3.1 CN1 Pin assignment (LCD Interface).....	5
3.2 CN2 Pin assignment (Back Light).....	6
3.3 Positions of socket.....	7
<b>4. ABSOLUTE MAXIMUM RATINGS .....</b>	<b>8</b>
<b>5. ELECTRICAL CHARACTERISTICS .....</b>	<b>9</b>
5.1 DC Characteristics for Panel Driving .....	9
5.2 DC Characteristics for Backlight Driving.....	10
5.3 Fuse .....	11
5.4 Power ON/OFF Sequence.....	11
5.5 LCD Module Block Diagram.....	12
<b>6. TIMING CHARACTERISTICS .....</b>	<b>13</b>
6.1 Data Input Timing Parameter Setting.....	13
6.2 AC Characteristics.....	14
<b>7. OPTICAL CHARACTERISTICS.....</b>	<b>15</b>
<b>8. RELIABILITY TEST .....</b>	<b>18</b>
<b>9. MECHANICAL DRAWING .....</b>	<b>19</b>
<b>10. MARKINGS.....</b>	<b>20</b>
<b>11. PACKING INSTRUCTION.....</b>	<b>21</b>
<b>12. PRECAUTIONS FOR USE OF LCD MODULES .....</b>	<b>24</b>
12.1 Handling Precautions.....	24
12.2 Storage precautions .....	24
12.3 Transportation Precautions.....	24
12.4 Screen saver Precautions.....	24
12.5 Safety Precautions .....	24

## 1. Summary

### 1.1 General Description

This is a 6.5 inch a-Si TFT-LCD module with Normal- black technology. It is composed of a TFT-LCD panel, a driver circuit, PCB, and a LED backlight unit.

### 1.2 Features

- Ultra-wide viewing angle (Super Fine TFT (SFT) )
- 70Khrs Long LED life time
- Interface: RGB 6-bit digital signals
- Without LED driver
- Compliant with the European RoHS Directive (2011/65/EU) and Delegated Directive (2015/863/EU, Amending Annex II of 2011/65/EU)
- Acquisition product for UL62368-1/CSA C22.2 No.62368-1-14 (File number: E333987)

## 2. General Specifications

Feature	Spec	Unit	
<b>Display Spec</b>	Size	6.5 inches	
	Resolution	640(RGB)x480	
	Pixel Pitch	0.207 (H) x 0.207(V)	mm
	TFT Active Area	132.48×99.36	mm
	Technology Type	a-Si	
	Pixel Configuration	R.G.B Vertical Stripe	
	Display Mode	SFT Normally black	
	Surface Treatment	AG	
	Polarizer pencil-hardness	3H	
	Viewing Direction	ALL	
<b>Mechanical Characteristics</b>	LCM (W x H x D)	153W* 118H * 8.2D(typ)	mm
	Weight	135	g
<b>Optical Characteristics</b>	Luminance	650	cd/m2
	Contrast Ratio	800:1	
	NTSC	45	%
	Viewing Angle	88/88/88/88	degree
	Polarizer absorption axis	Vertical	
<b>Electrical Characteristics</b>	Interface	RGB	
	Color Depth	262K	color
	Power Consumption	LCD:379.5typ Backlight: 1800typ	mW
	Recommended LED driver board (Option)	PB065QXGS01	

Table 2.1 General TFT Specifications

### 3. Input / Output Terminals

#### 3.1 CN1 Pin assignment (LCD Interface)

Connector Information	
LCD Module connector	DF9-31P-1V(32) (Hirose)
Matching connector	DF9-31S-1V(32) (Hirose) or equivalent

Table 3.1.1 Connector information

No	Symbol	I/O	Description	Comment
1	GND	P	Ground	
2	CLK	I	Dot clock	
3	Hsync	I	Horizontal synchronous signal	
4	Vsync	I	Vertical synchronous signal	
5	GND	P	Ground	
6	R0	I	Red data	
7	R1	I	Red data	
8	R2	I	Red data	
9	R3	I	Red data	
10	R4	I	Red data	
11	R5	I	Red data	
12	GND	P	Ground	
13	G0	I	Green data	
14	G1	I	Green data	
15	G2	I	Green data	
16	G3	I	Green data	
17	G4	I	Green data	
18	G5	I	Green data	
19	GND	P	Ground	
20	B0	I	Blue data	
21	B1	I	Blue data	
22	B2	I	Blue data	
23	B3	I	Blue data	
24	B4	I	Blue data	
25	B5	I	Blue data	
26	GND	P	Ground	
27	DE	I	Data enable	Leave it open in SYNC Mode
28	VCC	P	Power supply	
29	VCC	P	Power supply	
30	MODE	I	Select DE or SYNC mode	High or Open: DE Mode Low: SYNC Mode
31	DPS	I	Selection of scan direction	Low or Open: Normal scan High: Reverse scan

**Table 3.1.2 Pin Assignment for LCD Interface**

Note1: I/O definition: I---Input, O---Output, P---Power/Ground, N---No connection

Note2: All of the GND pins should be connected to the system ground.

**3.2 CN2 Pin assignment (Back Light)**

Connector Information	
Back Light connector	MS24011P8RA(STM)
Matching connector	P24011P8 (STM), SHR-08V-S (JST) or equivalent

**Table 3.2.1 Connector information**

No	Symbol	I/O	Description	Comment
1	A1	P	Anode1	
2	K1	P	Cathode1	
3	A2	P	Anode2	
4	K2	P	Cathode2	
5	A3	P	Anode3	
6	K3	P	Cathode3	
7	N. C.	N	-	Keep this pin Open.
8	N. C.	N	-	Keep this pin Open.

**Table 3.2.2 Pin Assignment for Back Light Interface**

Note1: I/O definition: I---Input, O---Output, P---Power/Ground, N---No connection

### 3.3 Positions of socket

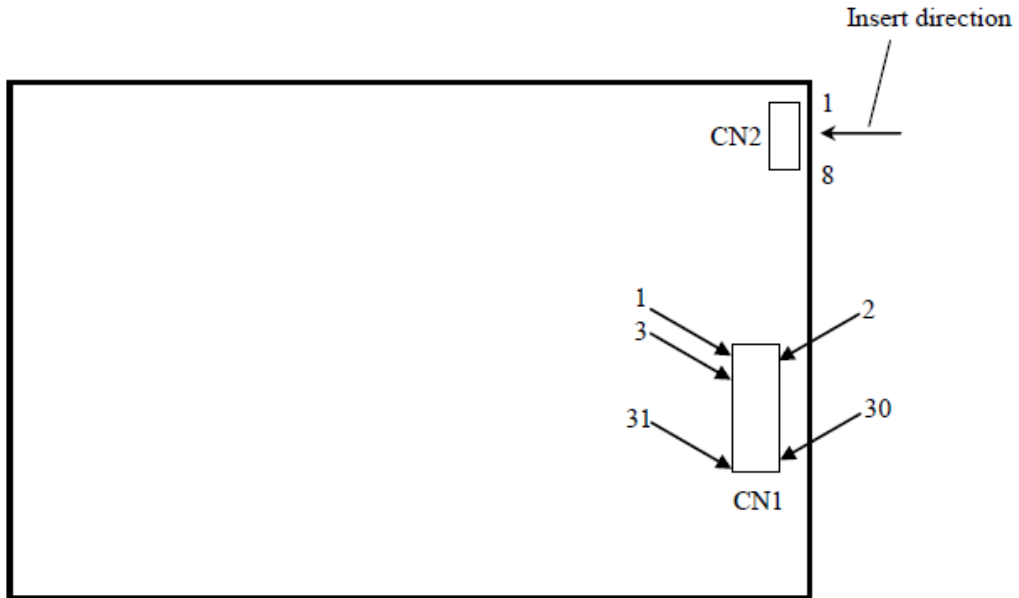

#### 4. Absolute Maximum Ratings

GND=0V

Item	Symbol	MIN	MAX	Unit	Remark
Power Supply Voltage	VCC	-0.3	5.0	V	Note1
Digital Input Voltage	V <sub>IO</sub>	-0.3	VCC+0.3	V	
Storage temperature	T <sub>st</sub>	-30 to +80		°C	Note2
Operating temperature	TopF	-30 to +80		°C	Note3
	TopR	-30 to +80		°C	Note4
Relative Humidity Note4	RH	--	≤95	%	T <sub>a</sub> ≤40°C
		--	≤85	%	40°C < T <sub>a</sub> ≤ 50°C
		--	≤55	%	50°C < T <sub>a</sub> ≤ 60°C
		--	≤36	%	60°C < T <sub>a</sub> ≤ 70°C
		--	≤24	%	70°C < T <sub>a</sub> ≤ 80°C
Absolute Humidity Note5	AH	--	≤70 Note5	g/m <sup>3</sup>	T <sub>a</sub> > 80°C

**Table 4.1 Absolute Maximum Ratings**

Note1: Digital input voltage includes DPS, MODE

Note2: Measured at LCD panel surface (including self-heat)

Note3: Measured at LCD module's rear shield surface (including self-heat)

Note4: No condensation

Note5: Water amount at T<sub>a</sub>= 80 °C and RH= 24%

## 5. Electrical Characteristics

### 5.1 DC Characteristics for Panel Driving

Item	Symbol	MIN	TYP	MAX	Unit	Remark
Power supply Voltage	VCC	3.0	3.3	3.6	V	Include ripple
Power supply current	IVCC	-	115	165	mA	at VCC=3.3V Note1
Power supply ripple	Vp-p	-	-	100	mA	for VCC
Digital input voltage	Low Level	VIL	GND	--	V	Note2
	High Level	VIH	0.7*VCC	--	V	

**Table 5.1.1 DC characteristics**

Note1: To test the current dissipation, using the “white “testing pattern.

Note2: Digital input voltage includes DPS,MODE

### 5.2 DC Characteristics for Backlight Driving

Item	Symbol	MIN	TYP	MAX	Unit	Remark
Forward Current	$I_F$	-	50	55	mA	12 LEDs (4 LED Serial, 3 LED Parallel)
Forward Current Voltage	$V_F$	-	12.0	13.7	V	
Backlight Power Consumption	$W_{BL}$	-	1800	-	mW	
Operating Life Time	--	-	70000	-	hrs	Note

Table 5.2.1 LED Backlight Characteristics

Note1:  $I_F$  is defined for Current value of one LED circuit

Note2: Optical performance should be evaluated at  $T_a=25^{\circ}C$  only.

Note3: If LED is driven by high current, high ambient temperature & humidity condition. The life time of LED will be reduced.

Note4: Operating life means brightness goes down to 50% of initial brightness. Typical operating life time is estimated data.

Backlight

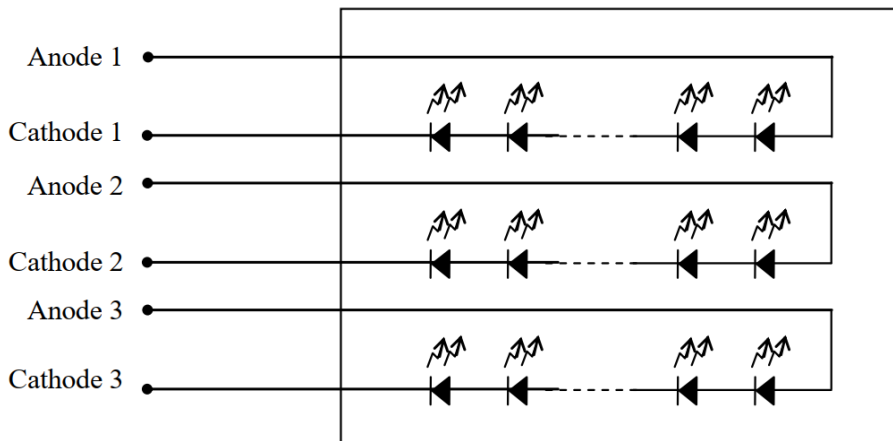

5.3 Fuse

Parameter	Fuse		Rating	Fusing current	Remarks
	Type	Supplier			
VCC	F0603HI2000V032T	AEM	2.0A	4.0A	/
			32V		

5.4 Power ON/OFF Sequence

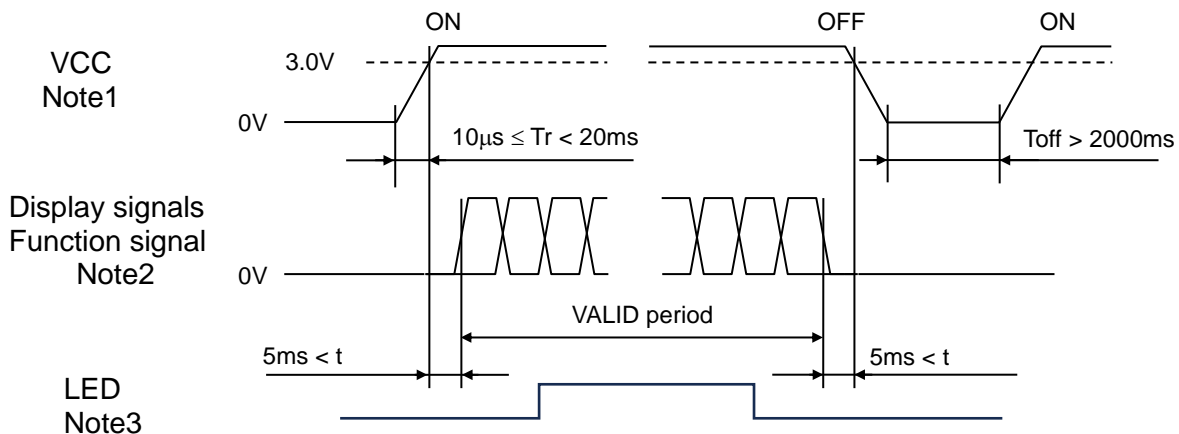

Figure 5.3 Power on/off sequence

Note1: If there is a voltage variation (voltage drop) at the rising edge of VCC below 3.0V , there is a possibility that a product does not work due to a protection circuit.

Note2: Display signals (CLK, Hsync, Vsync, DE, DATA (R0 to R5, G0 to G5, B0 to B5)) and function signal (DPS,MODE) must be set to Low or High-impedance, except the VALID period (See above sequence diagram), in order to avoid the circuitry damage.

If some of display and function signals of this product are cut while this product is working, even if the signal input to it once again, it might not work normally. If a customer stops the display and function signals, VCC also must be shut down.

Note3: Keep backlight turn off until the display has stabilized.

5.5 LCD Module Block Diagram

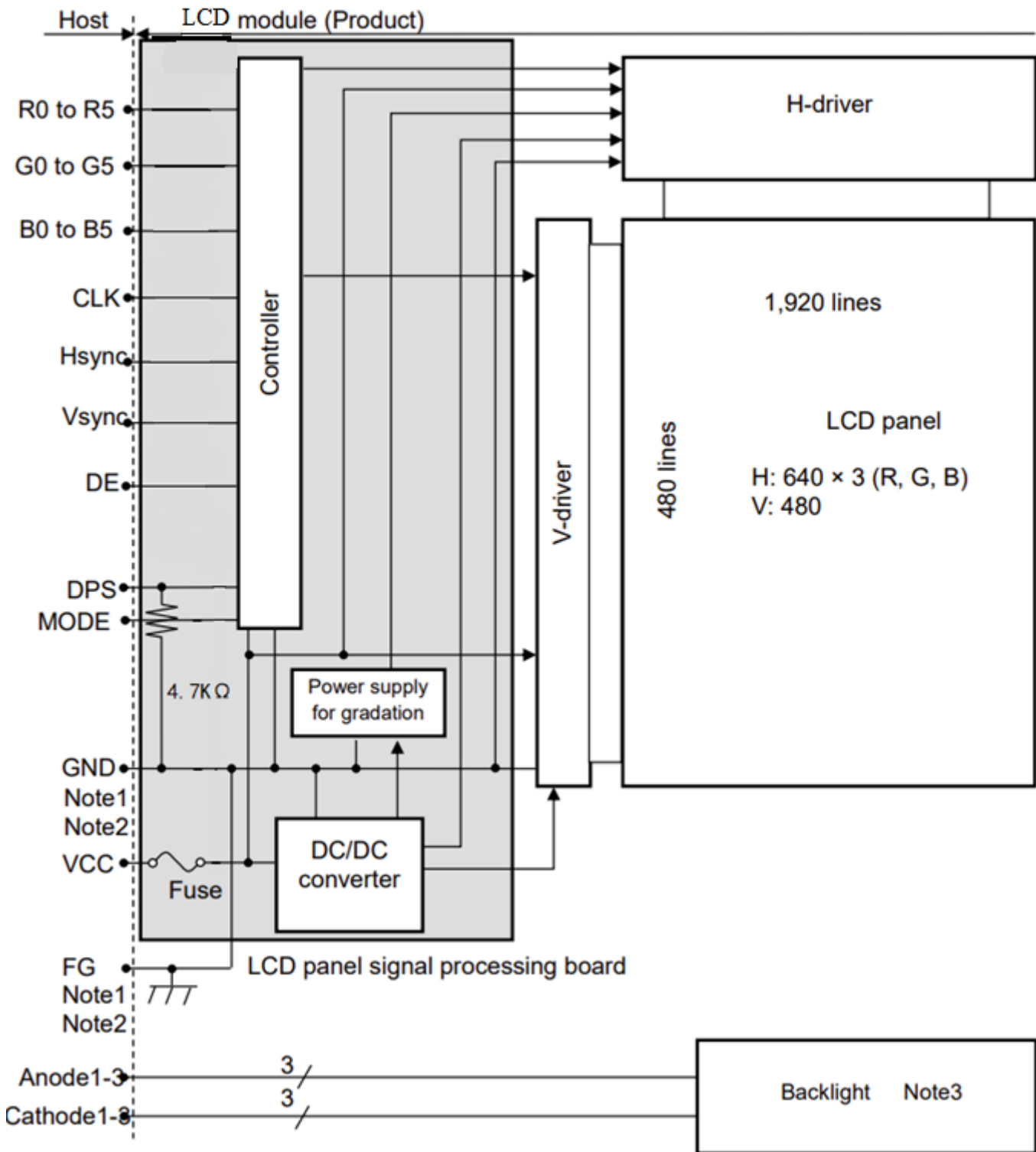

Figure 5.6.1 LCD Module Block Diagram

Note1: Relation between GND (Signal ground) and FG (Frame ground) in the LCD module is as follows.

GND - FG	Connected
----------	-----------

Note2: GND and FG must be connected to customer equipment's ground, and it is recommended that these grounds to be connected together in customer equipment.

Note3: See 5.2 for details

## 6. Timing Characteristics

### 6.1 Data Input Timing Parameter Setting

VCC=3.3V, GND=0V, Ta=25°C

(a) Sync mode

Parameter		Symbol	min.	typ.	max.	Unit	Remarks
CLK	Frequency	1/tc	23.1	25.2	27.1	MHz	Note1
Hsync	Cycle	t <sub>H</sub>	744	800	840	CLK	
	Display period	t <sub>HD</sub>	640			CLK	
	Front-porch	t <sub>HFP</sub>	80	136	176	CLK	
	Pulse width	t <sub>HPW</sub>	2	-	5	CLK	
	Back-porch	t <sub>HBP</sub>	13	-	16	CLK	
	Total of pulse width and back-porch	t <sub>HPW</sub> + t <sub>HBP</sub>	18			CLK	
Vsync	Cycle	t <sub>V</sub>	517	525	537	H	
	Display period	t <sub>VD</sub>	480			H	
	Front-porch	t <sub>VFP</sub>	17	25	37	H	
	Pulse width	t <sub>VPW</sub>	2	-	5	H	
	Back-porch	t <sub>VBP</sub>	7	-	10	H	
	Total of pulse width and back-porch	t <sub>VPW</sub> + t <sub>VBP</sub>	12				
FR	Frame Rate	FR	60			Hz	

Figure 6.1.1 Input Timing Parameters on Fixed Mode

Note1: Definition of parameters is as follows.

$$t_c = 1\text{CLK}, t_h = 1\text{H}$$

(b) DE mode

Parameter		Symbol	min.	typ.	max.	Unit	Remarks	
CLK	Frequency	1/tc	23.1	25.2	27.1	MHz	Note1	
DE	Horizontal	Cycle	t <sub>h</sub>	744	800	840		CLK
		Display period	t <sub>HD</sub>	640			CLK	Note2
	Vertical (One frame)	Cycle	t <sub>v</sub>	517	525	537	H	Note3
		Display period	t <sub>VD</sub>	480			H	-
FR	Frame Rate	FR	60			Hz	-	

Figure 6.1.1 Input Timing Parameters on DE Mode

Note1: Definition of parameters is as follows.

$$t_c = 1\text{CLK}, t_h = 1\text{H}$$

Note2: Hsync signal (Pin No.3 of CN1) and Vsync signal (Pin No.4 of CN1) are not used inside the product at DE mode.

Do not keep pin open to avoid noise problem.

Note3: Vertical cycle (t<sub>v</sub>) should be specified in integral multiple of Horizontal cycle (t<sub>h</sub>).

Table 6.1.1 Data Input Timing Parameters

6.2 AC Characteristics

Input Clock and Data Timing Diagram

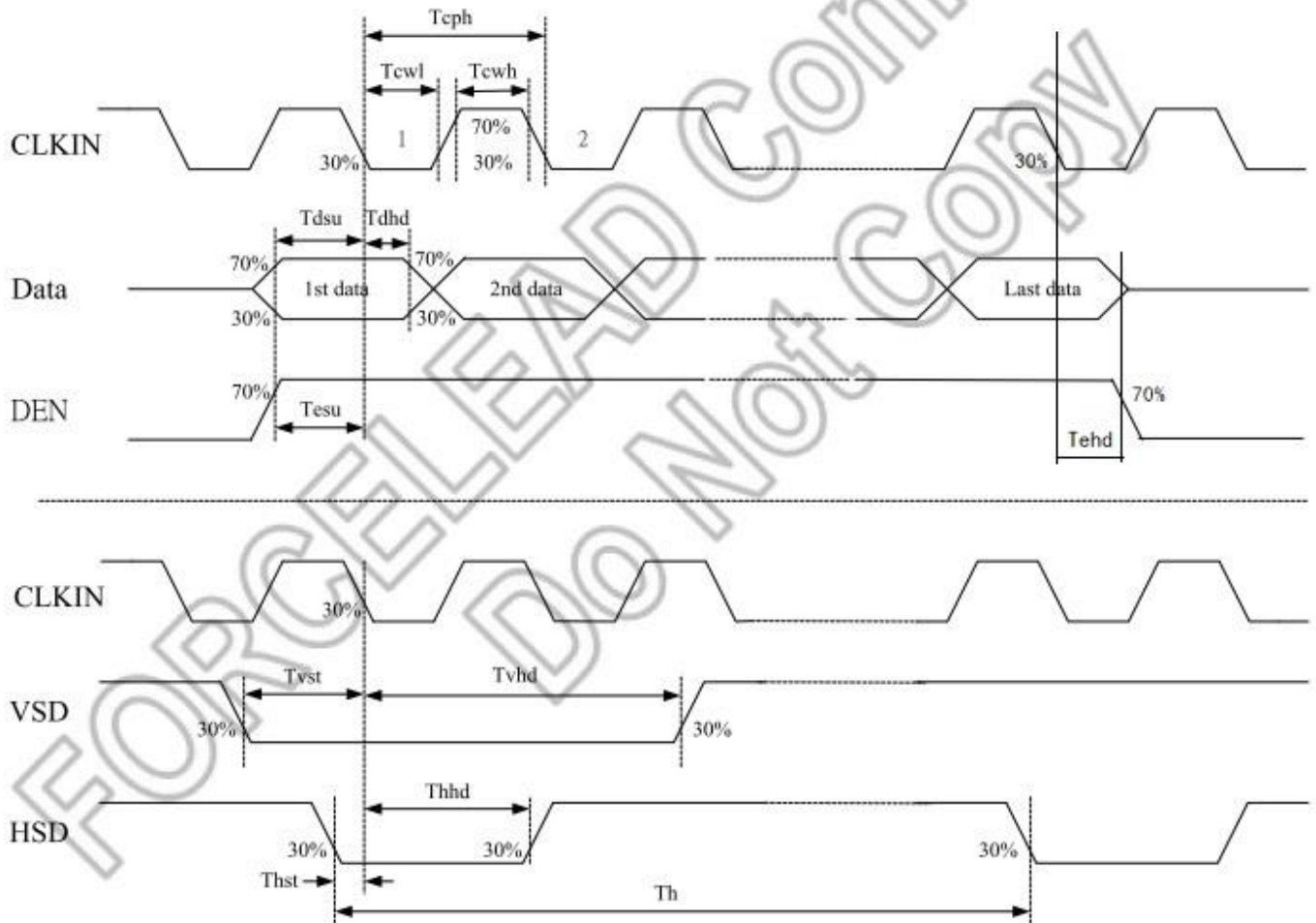

Item	Signal	Symbol	Condition	Rating		Unit
				Min.	Max.	
CLK cycle time	CLK	$T_{cph}$	-	36.9	43.3	ns
CLK pulse high duty		$T_{cwh}$	-	40	60	%
CLK pulse low duty		$T_{cwl}$	-	40	60	
Vsync setup time	Vsync	$T_{vst}$	-	4	-	ns
Vsync hold time		$T_{vhd}$	-	2	-	
Hsync setup time	Hsync	$T_{hst}$	-	4	-	
Hsync hold time		$T_{hhd}$	-	2	-	
Data setup time	R[0:5] G[0:5] B[0:5]	$T_{dsu}$	-	4	-	
Data hold time		$T_{dhd}$	-	2	-	
DE setup time	DE	$T_{esu}$	-	4	-	
DE hold time		$T_{ehd}$	-	2	-	

**7. Optical Characteristics**

Item	Symbol	Condition	Min	Typ	Max	Unit	Remark
View Angles	$\theta_U$	$CR \geq 10$	70	88	-	Degree	Note 2
	$\theta_D$		70	88	-		
	$\theta_L$		70	88	-		
	$\theta_R$		70	88	-		
Contrast Ratio	CR	$\theta=0^\circ$	500	800	-		Note1 Note3
Response Time	$T_{ON}$	25°C		25	35	ms	Note1 Note4
	$T_{OFF}$						
Chromaticity	White	x	Backlight is on	0.254	0.304	0.354	Note1 Note5
		y		0.287	0.337	0.387	
	Red	x		0.541	0.591	0.641	
		y		0.308	0.358	0.408	
	Green	x		0.242	0.292	0.342	
		y		0.501	0.551	0.601	
	Blue	x		0.111	0.161	0.211	
		y		0.100	0.150	0.200	
Uniformity	U		72	80	-	%	Note1 Note6
NTSC			40	45	-	%	Note 5
Luminance( Without TP)	L		570	650	-	cd/m <sup>2</sup>	Note1 Note7

**Table 7.1 Optical Parameters**

Test Conditions:

1.  $I_F= 50mA$ , and the ambient temperature is  $25^\circ C \pm 2^\circ C$ , humidity is  $65 \pm 7\%$ .
2. The test systems refer to Note1 ~Note7.

Note1: Definition of optical measurement system.

The optical characteristics should be measured in dark room. After 5 Minutes operation, the optical characteristics are measured at the center point of the LCD screen.

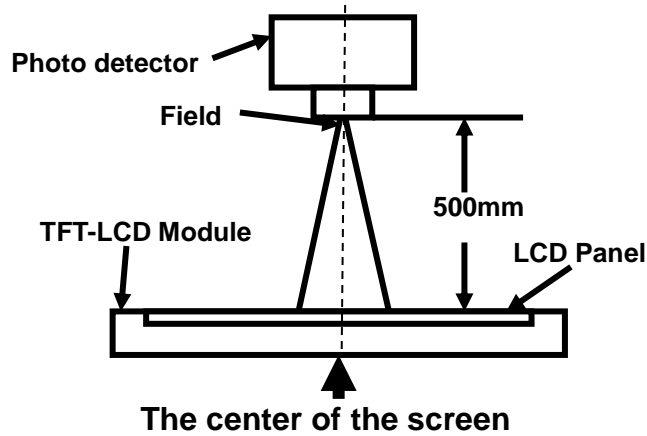

Fig1. Measurement Set Up

Note2: Definition of viewing angle range and measurement system. Viewing angle is measured at the center point of the LCD .

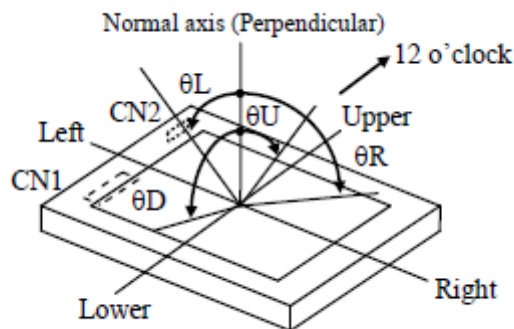

Fig2. Measurement viewing angle

Note3: Definition of contrast ratio

$$\text{Contrast ratio (CR)} = \frac{\text{Luminance measured when LCD is on the "White" state}}{\text{Luminance measured when LCD is on the "Black" state}}$$

Note4: Definition of Response time

For SFT LCM, the response time is defined as the LCD optical switching time interval between “White” state and “Black” state. Rise time ( $T_r$ ) is the time between photo detector output intensity changed from 10% to 90%. And fall time ( $T_f$ ) is the time between photo detector output intensity changed from 90% to 10%.

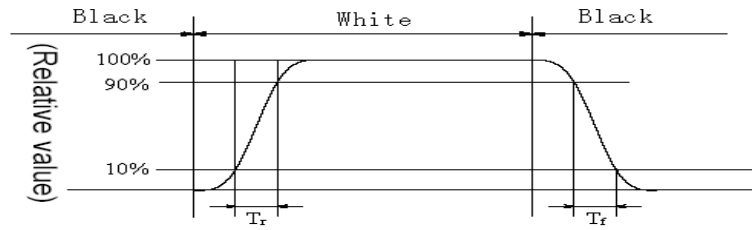

Fig4. Response Time Testing(SFT)

Note5: Definition of color chromaticity (CIE1931)

Color coordinates measured at center point of LCD.

Note6: Definition of Luminance Uniformity

Active area is divided into 9 measuring areas (Refer Fig.5). Every measuring point is placed at the center of each measuring area.

Luminance Uniformity (U) =  $L_{min} / L_{max}$

$L_{max}$ : The measured Maximum luminance of all measurement position.

$L_{min}$ : The measured Minimum luminance of all measurement position.

L-----Active area length; W----- Active area width

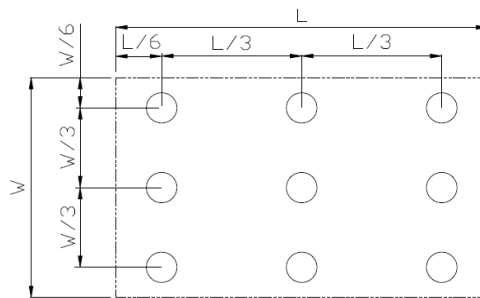

Fig5. Luminance Uniformity Measurement Locations(9 points)

Note7: Definition of Luminance:

Measure the luminance of white state at center point.

## 8. Reliability Test

No	Test Item	Condition	Remarks
1	High Temperature Operation	Ta = +80°C, 240 hours	IEC60068-2-2:2007 GB2423.2-2008
2	Low Temperature Operation	Ta = -30°C, 240 hours	IEC60068-2-1:2007 GB2423.1-2008
3	High Temperature Storage	Ta = +80°C, 240hours	IEC60068-2-2:2007 GB2423.2-2008
4	Low Temperature Storage	Ta = -30°C, 240 hours	IEC60068-2-1:2007 GB2423.1-2008
5	High Temperature and Humidity Operation	Ta = +60°C, 90% RH max,240hours	IEC60068-2-78 :2012 GB/T2423.3—2016
6	Thermal Shock (non-operation)	-30°C 30 min~+80°C 30 min, Change time:5min, 100 Cycle	Start with cold temperature, End with high temperature, IEC60068-2-14:2009,GB2423.22-2012
7	ESD	C=150pF,R=150Ω,9point/panel Contact: ±10Kv,10times;	IEC61000-4-2:2008 GB/T17626.2-2018
8	Vibration Test (non-operation)	5~100HZ , 19.60m/s <sup>2</sup> 1min/cycle 120times Per X\Y\Z	IEC60068-2-6:2007 GB/T2423.10—2019
9	Shock Test (non-operation)	539m/s <sup>2</sup> , 11ms 5times ±X、 ±Y、 ±Z	GB/T 2423.5-1995
10	Package Drop Test	Height:60cm, 1corner,3edges,6surfaces	GB/T 4857.5-1995
11	Package Vibration	Frequency : 5-20-200HZ , PSD : 0.01-0.01-0.001 Total:0.781g <sup>2</sup> /HZ, x/y/z axis per 30min )	GB/T 4857.23-2021

**Table 8.1 RA test condition**

Note1: Temperature is the ambient temperature of sample

Note2: Before cosmetic and function test, the product must have enough recovery time, at least 24 hours at room temperature.

Note3: In the standard condition, there shall be no practical problem that may affect the display function. After the reliability test, the product's function only be guaranteed, but not for all of the cosmetic specification.

9. Mechanical Drawing

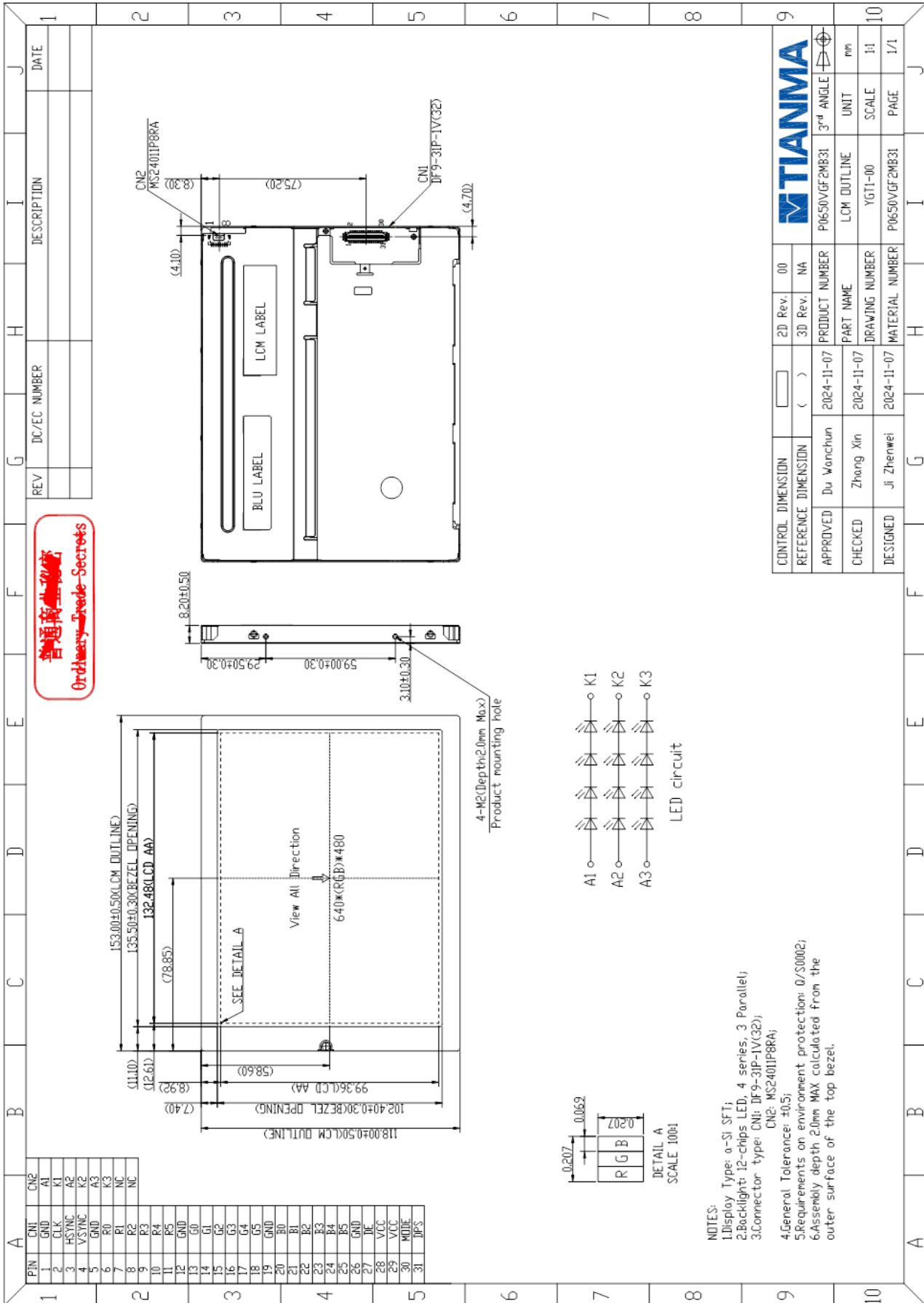

普通商业机密  
Ordinary Trade Secrets

CONTROL DIMENSION	2D Rev.	00	<b>TIANMA</b>	
REFERENCE DIMENSION	3D Rev.	NA		
APPROVED	Du Wanchun	2024-11-07	PRODUCT NUMBER	P0650VGF2MB31
CHECKED	Zhang Xin	2024-11-07	PART NAME	LCM OUTLINE
DESIGNED	Ji Zhenwei	2024-11-07	DRAWING NUMBER	YGT1-00
			MATERIAL NUMBER	P0650VGF2MB31
			UNIT	mm
			SCALE	1:1
			PAGE	1/1

## 10. Markings

The marking is attached to this product.

### 10.1 Nameplate label

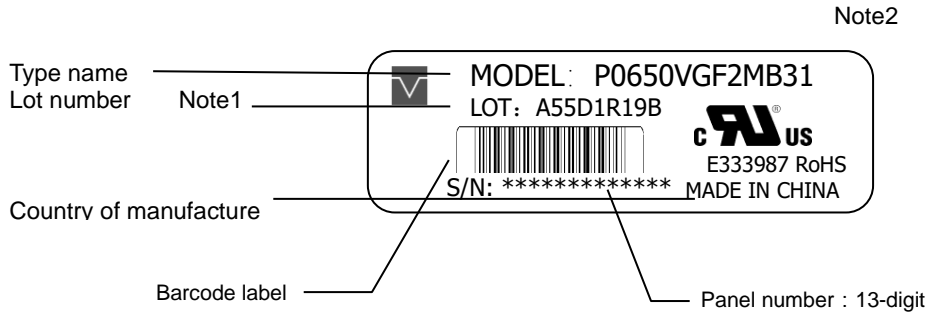

Note1: The meaning of lot number

- Example: A55D1R19B

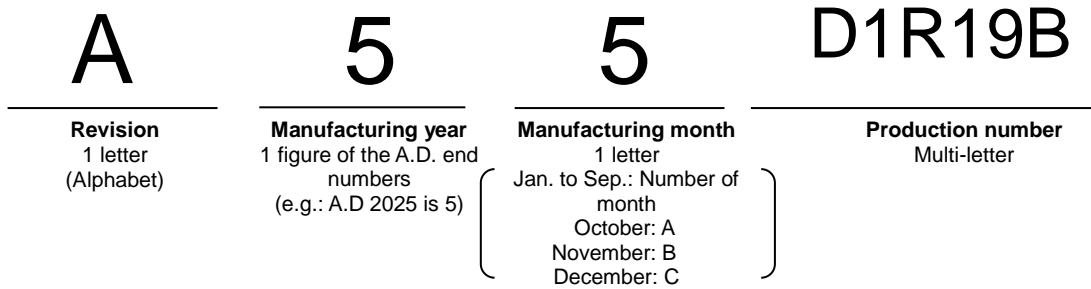

Note2: Do not attach anything like another label on the name plate label! In case of replacing the product, Tianma needs the contents of nameplate such as the lot number, inspection date and so on, to identify the warranty period with individual product. If Tianma cannot decipher the contents of nameplate, replacing shall be charged. Tianma also may give a new lot number to replaced products.

## 11. Packing Instruction

No	Item	Model (Material)	Dimensions(mm)	Unit Weight(Kg)	Quantity	Remark
1	LCM	P0650VGF2MB31	153.0×118.0×8.2	0.135	24	
2	Tray	PET	356×256×19.7	0.125	15	
3	Dust-proof Bag	PE	680×520	0.042	1	
4	EPE 1	EPE	336×246×6	0.01	6	
5	EPE 2	EPE	375×275×10	0.014	4	
6	EPE 3	EPE	250×280×12	0.015	2	
7	Carton	CORRUGATED PAPER	398×290×315	0.58	1	
8	Lable	tagboard	100×52	0.002	1	
9	Total weight	5.885 Kg				

Table 10.1 Packing Instruction

### Packaging Specification and Quantity)

(1) LCM quantity per tray:2

(2) Total LCM quantity per group:8(4 trays+1 tray)

(3) Total LCM quantity in Carton: Number of PET trays 12×quantity per tray 2= 24

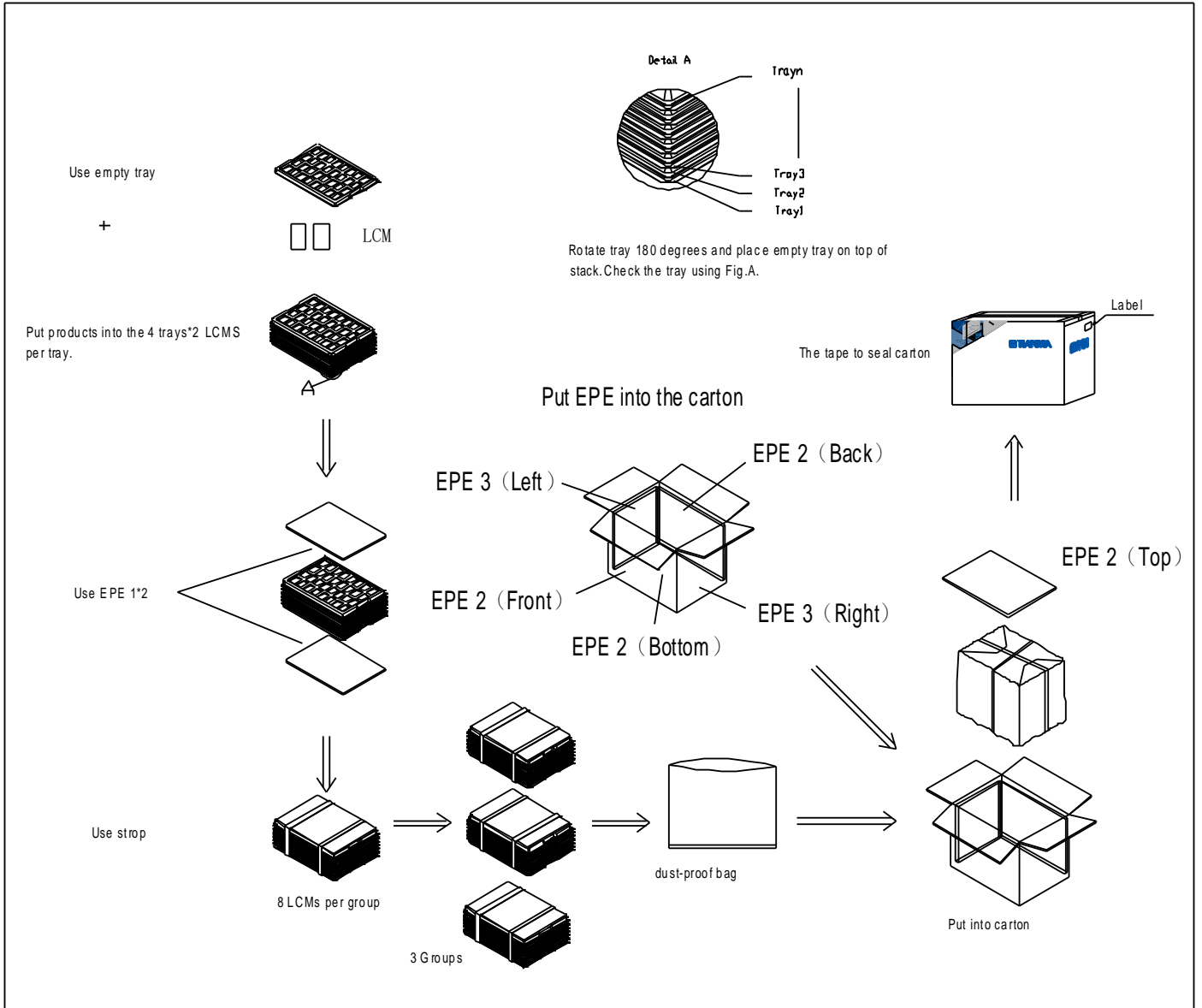
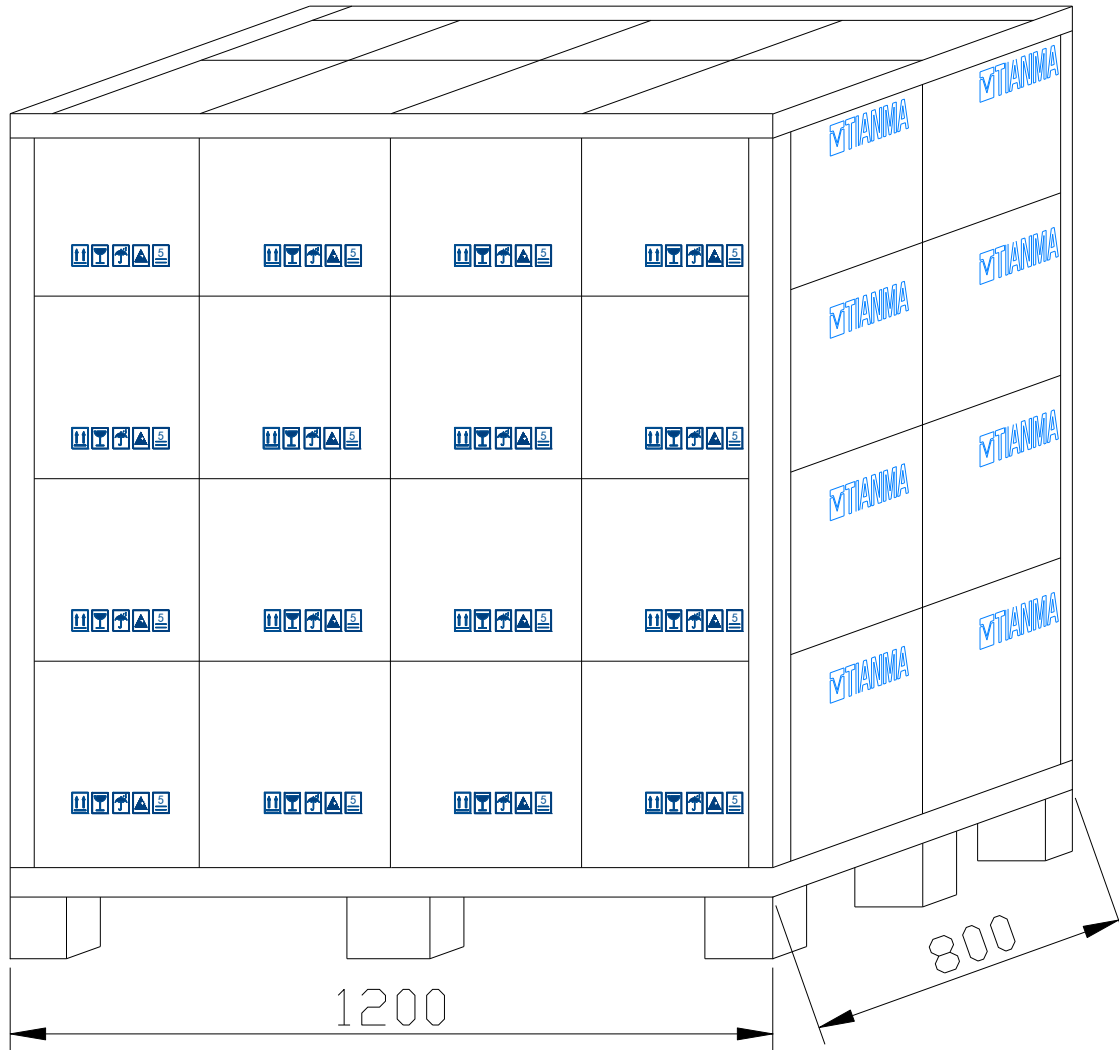

Figure 10.1 Packing Instruction

### Stack placement

The number of cartons stacked is 2 x 4/ each layer x 4 layers in total

Below dimensions unit: mm



## 12. Precautions for Use of LCD Modules

### 12.1 Handling Precautions

- (1) The display panel is made of glass. Do not subject it to mechanical shock by dropping it, etc.
- (2) If the display panel is damaged and the liquid crystal fluid inside it leaks out be sure not to get any in your mouth. If the fluid comes into contact with your skin or clothes promptly wash it off using soap and water.
- (3) Do not apply excessive force to the display surface or the bezel since this may cause the color tone to vary.
- (4) The polarizer covering the display surface of the LCD module is soft and easily scratched. Handle the polarizer carefully.
- (5) If the display surface is contaminated, breathe on the surface and gently wipe it with a soft dry cloth. If it is still not completely clear use a moist cloth with one of the following solvents:
  - Isopropyl alcohol
  - Ethyl alcoholSolvents other than those mentioned above may damage the polarizer. Specifically, do not use the following:
  - Water
  - Ketone
  - Aromatic solvents
- (6) Do not disassemble the LCD Module.
- (7) If powered off, do not apply the input signals.
- (8) To prevent destruction of the module by static electricity, be careful to maintain an optimum work environment.
- (9) Be sure to ground your body when handling the LCD Modules.
- (10) Tools used for assembly, must be properly grounded.
- (11) To reduce the amount of static electricity generated, do not conduct assembly or other work under very low humidity conditions.
- (12) The LCD Module is covered with a film to protect the display surface, remove film slowly under the ionizer.

### 12.2 Storage precautions

- (1) When storing the LCD modules avoid exposure to direct sunlight or to the light of fluorescent lamps.
- (2) The LCD modules should be stored within the rated storage temperature range. The recommend condition is:  
Temperature: 0 ~ 35 °C at normal humidity.
- (3) The LCD modules should be stored in a room without acid, alkali or other harmful gas.

### 12.3 Transportation Precautions

The LCD modules should not be dropped or subject to violent mechanical shock during transportation. Also they should avoid excessive pressure, water, high humidity and direct sunlight.

### 12.4 Screen saver Precautions

Not display the fixed pattern for a long time. Use a screen saver, if the fixed pattern is displayed on the screen

### 12.5 Safety Precautions

- (1) When you waste damaged or unnecessary LCDs, it is recommended to crush LCDs into pieces and wash them off with solvents such as acetone and ethanol, which should later be burned
- (2) Be sure to turn off the power supply when inserting or disconnecting the LED backlight cable.
- (3) LED driver should be designed to limit or stop its function when over current is detected on the LED.