

EXAMINED BY :	EMERGING DISPLAY TECHNOLOGIES CORPORATION	FILE NO . CAS-0009518
Lucica Lu		ISSUE : DEC.03, 2024
APPROVED BY:		TOTAL PAGE : 28
Vincent Wn		VERSION : 3

CUSTOMER ACCEPTANCE SPECIFICATIONS

MODEL NO. :

ETML156025LDYA

(RoHS)

FOR MESSRS :

CUSTOMER'S APPROVAL

DATE :

BY :

RECORDS OF REVISION

DOC . FIRST ISSUE

MAR.29, 2023

DATE	REVISED PAGE NO.	SUMMARY																																															
SEP.20, 2024	1	1.1 DATA SHEETS FOR TFT MODULE CONTROLLER/DRIVER PLEASE REFER TO: TBD→HX-8255B 2.1 LCD MODULE MECHANICAL SPECIFICATIONS (12)INTERFACE MODE: LVDS→LVDS(VESA) (13)WEIGHT: TBD→1213g																																															
	2	2.2 CAPACITIVE TOUCH PANEL MECHANICAL SPECIFICATIONS (4)INPUT TYPE: MULTI-TOUCH→TOUCH : MULTI POINT HOVER : SINGLE POINT (6)RESOLUTION: 1920*1080→65536*65536																																															
	3	3.1 TFT MODULE ELECTRICAL ABSOLUTE MAXIMUM RATINGS <table border="1"> <thead> <tr> <th>ITEM</th> <th>MIN.</th> <th>MAX.</th> </tr> </thead> <tbody> <tr> <td>POWER SUPPLY VOLTAGE</td> <td>(-0.3)</td> <td>(4.0)</td> </tr> <tr> <td>POWER SUPPLY VOLTAGE FOR LED DRIVER</td> <td>(-0.3)</td> <td>(27J)</td> </tr> </tbody> </table> <table border="1"> <thead> <tr> <th>ITEM</th> <th>MIN.</th> <th>MAX.</th> </tr> </thead> <tbody> <tr> <td>POWER SUPPLY VOLTAGE</td> <td>-0.3</td> <td>4.0</td> </tr> <tr> <td>POWER SUPPLY VOLTAGE FOR LED DRIVER</td> <td>-0.3</td> <td>27</td> </tr> </tbody> </table> 3.2 CAPACITIVE TOUCH PANEL ELECTRICAL ABSOLUTE MAXIMUM RATINGS ITEM: POWER SUPPLY FOR DRIVER, SYMBOL: VCC-GND→VDD1-VSS1 3.3 ENVIRONMENTAL ABSOLUTE MAXIMUM RATINGS NOTE(4):WHEN THE LCD MODULE IS OPERATED AT AMBIENT TEMPERATURE 80°C, THE PWM DUTY CYCLE OF THE LED BACKLIGHT SHOULD BE ADJUSTED TO BE LESS THAN TBD. IF THE MODULE IS OPERATED AT A HIGHER DUTY CYCLE THAN TBD, THEN THERE IS A POSSIBILITY OF DISTORTION AND IRREGULARITY OF THE PICTURE DUE TO LIQUID CRYSTAL BEHAVIOR. →WHEN THE LCD MODULE IS OPERATED AT AMBIENT TEMPERATURE 80°C, THE PWM DUTY CYCLE OF THE LED BACKLIGHT SHOULD BE ADJUSTED TO BE LESS THAN 30%. IF THE MODULE IS OPERATED AT A HIGHER DUTY CYCLE THAN 40%, THEN THERE IS A POSSIBILITY OF DISTORTION AND IRREGULARITY OF THE PICTURE DUE TO LIQUID CRYSTAL BEHAVIOR.	ITEM	MIN.	MAX.	POWER SUPPLY VOLTAGE	(-0.3)	(4.0)	POWER SUPPLY VOLTAGE FOR LED DRIVER	(-0.3)	(27J)	ITEM	MIN.	MAX.	POWER SUPPLY VOLTAGE	-0.3	4.0	POWER SUPPLY VOLTAGE FOR LED DRIVER	-0.3	27																													
	ITEM	MIN.	MAX.																																														
POWER SUPPLY VOLTAGE	(-0.3)	(4.0)																																															
POWER SUPPLY VOLTAGE FOR LED DRIVER	(-0.3)	(27J)																																															
ITEM	MIN.	MAX.																																															
POWER SUPPLY VOLTAGE	-0.3	4.0																																															
POWER SUPPLY VOLTAGE FOR LED DRIVER	-0.3	27																																															
4	4.1 LCD MODULE ELECTRICAL CHARACTERISTICS <table border="1"> <thead> <tr> <th>ITEM</th> <th>MIN.</th> <th>TYP.</th> <th>MAX.</th> </tr> </thead> <tbody> <tr> <td>POWER SUPPLY VOLTAGE</td> <td>(3.15)</td> <td>(3.3)</td> <td>(3.45)</td> </tr> <tr> <td>POWER SUPPLY CURRENT</td> <td>—</td> <td>—</td> <td>(454)</td> </tr> <tr> <td>POWER SUPPLY VOLTAGE FOR LED DRIVER</td> <td>(10.8)</td> <td>(12)</td> <td>(13.2)</td> </tr> <tr> <td>POWER SUPPLY CURRENT FOR LED DRIVER</td> <td>—</td> <td>(2)</td> <td>(3)</td> </tr> <tr> <td>LED LIFE TIME</td> <td>(50K)</td> <td>—</td> <td>—</td> </tr> </tbody> </table> <table border="1"> <thead> <tr> <th>ITEM</th> <th>MIN.</th> <th>TYP.</th> <th>MAX.</th> </tr> </thead> <tbody> <tr> <td>POWER SUPPLY VOLTAGE</td> <td>3.15</td> <td>3.3</td> <td>3.45</td> </tr> <tr> <td>POWER SUPPLY CURRENT</td> <td>—</td> <td>350</td> <td>454</td> </tr> <tr> <td>POWER SUPPLY VOLTAGE FOR LED DRIVER</td> <td>10.8</td> <td>12</td> <td>13.2</td> </tr> <tr> <td>POWER SUPPLY CURRENT FOR LED DRIVER</td> <td>—</td> <td>2</td> <td>2.6</td> </tr> <tr> <td>LED LIFE TIME</td> <td>50K</td> <td>—</td> <td>—</td> </tr> </tbody> </table>	ITEM	MIN.	TYP.	MAX.	POWER SUPPLY VOLTAGE	(3.15)	(3.3)	(3.45)	POWER SUPPLY CURRENT	—	—	(454)	POWER SUPPLY VOLTAGE FOR LED DRIVER	(10.8)	(12)	(13.2)	POWER SUPPLY CURRENT FOR LED DRIVER	—	(2)	(3)	LED LIFE TIME	(50K)	—	—	ITEM	MIN.	TYP.	MAX.	POWER SUPPLY VOLTAGE	3.15	3.3	3.45	POWER SUPPLY CURRENT	—	350	454	POWER SUPPLY VOLTAGE FOR LED DRIVER	10.8	12	13.2	POWER SUPPLY CURRENT FOR LED DRIVER	—	2	2.6	LED LIFE TIME	50K	—	—
ITEM	MIN.	TYP.	MAX.																																														
POWER SUPPLY VOLTAGE	(3.15)	(3.3)	(3.45)																																														
POWER SUPPLY CURRENT	—	—	(454)																																														
POWER SUPPLY VOLTAGE FOR LED DRIVER	(10.8)	(12)	(13.2)																																														
POWER SUPPLY CURRENT FOR LED DRIVER	—	(2)	(3)																																														
LED LIFE TIME	(50K)	—	—																																														
ITEM	MIN.	TYP.	MAX.																																														
POWER SUPPLY VOLTAGE	3.15	3.3	3.45																																														
POWER SUPPLY CURRENT	—	350	454																																														
POWER SUPPLY VOLTAGE FOR LED DRIVER	10.8	12	13.2																																														
POWER SUPPLY CURRENT FOR LED DRIVER	—	2	2.6																																														
LED LIFE TIME	50K	—	—																																														
5	4.2 CAPACITIVE TOUCH PANEL ELECTRICAL CHARACTERISTICS <table border="1"> <thead> <tr> <th>ITEM</th> <th>SYMBOL</th> <th>CONDITION</th> <th>MIN.</th> <th>TYP.</th> <th>MAX.</th> </tr> </thead> <tbody> <tr> <td>POWER SUPPLY FOR DRIVER</td> <td>VCC-GND</td> <td>—</td> <td>(3.15)</td> <td>(3.3)</td> <td>(3.45)</td> </tr> <tr> <td>POWER SUPPLY CURRENT CONSUMPTION FOR OPERATION</td> <td>ICC</td> <td>VCC-GND =3.3V</td> <td>—</td> <td>(250)</td> <td>(300)</td> </tr> </tbody> </table> <table border="1"> <thead> <tr> <th>ITEM</th> <th>SYMBOL</th> <th>CONDITION</th> <th>MIN.</th> <th>TYP.</th> <th>MAX.</th> </tr> </thead> <tbody> <tr> <td>POWER SUPPLY FOR DRIVER</td> <td>VDD1-VSS1</td> <td>—</td> <td>3.15</td> <td>3.3</td> <td>3.45</td> </tr> <tr> <td>POWER SUPPLY CURRENT CONSUMPTION FOR OPERATION</td> <td>IDD1</td> <td>VDD1-VSS1 =3.3V</td> <td>—</td> <td>250</td> <td>325</td> </tr> </tbody> </table>	ITEM	SYMBOL	CONDITION	MIN.	TYP.	MAX.	POWER SUPPLY FOR DRIVER	VCC-GND	—	(3.15)	(3.3)	(3.45)	POWER SUPPLY CURRENT CONSUMPTION FOR OPERATION	ICC	VCC-GND =3.3V	—	(250)	(300)	ITEM	SYMBOL	CONDITION	MIN.	TYP.	MAX.	POWER SUPPLY FOR DRIVER	VDD1-VSS1	—	3.15	3.3	3.45	POWER SUPPLY CURRENT CONSUMPTION FOR OPERATION	IDD1	VDD1-VSS1 =3.3V	—	250	325												
ITEM	SYMBOL	CONDITION	MIN.	TYP.	MAX.																																												
POWER SUPPLY FOR DRIVER	VCC-GND	—	(3.15)	(3.3)	(3.45)																																												
POWER SUPPLY CURRENT CONSUMPTION FOR OPERATION	ICC	VCC-GND =3.3V	—	(250)	(300)																																												
ITEM	SYMBOL	CONDITION	MIN.	TYP.	MAX.																																												
POWER SUPPLY FOR DRIVER	VDD1-VSS1	—	3.15	3.3	3.45																																												
POWER SUPPLY CURRENT CONSUMPTION FOR OPERATION	IDD1	VDD1-VSS1 =3.3V	—	250	325																																												

RECORDS OF REVISION

MAR.29, 2023

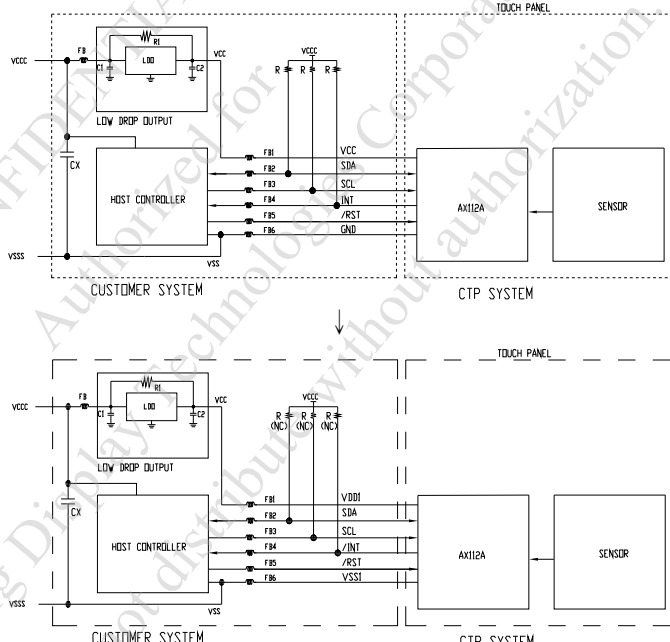
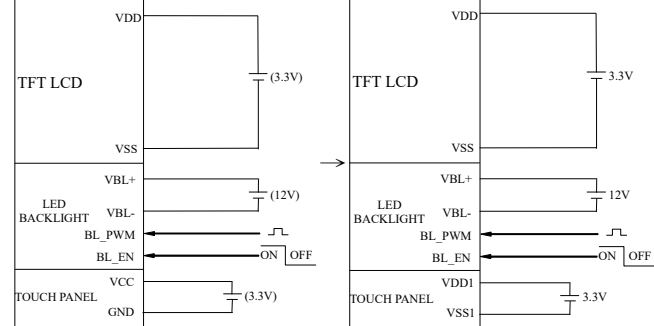
DATE	REVISED PAGE NO.	SUMMARY																																																																																												
SEP.20, 2024	6	<p>6.1 OPTICAL CHARACTERISTICS(NOTE 1)</p> <table border="1" data-bbox="596 488 976 835"> <thead> <tr> <th>ITEM</th> <th>MIN.</th> <th>TYP.</th> <th>MAX.</th> </tr> </thead> <tbody> <tr> <td rowspan="4">VIEWING ANGLE</td> <td>(80)</td> <td>(85)</td> <td>—</td> </tr> <tr> <td>(80)</td> <td>(85)</td> <td>—</td> </tr> <tr> <td>(80)</td> <td>(85)</td> <td>—</td> </tr> <tr> <td>(80)</td> <td>(85)</td> <td>—</td> </tr> <tr> <td>CONTRAST RATIO (CENTER)</td> <td>(700)</td> <td>(1000)</td> <td>—</td> </tr> <tr> <td>RESPONSE TIME</td> <td>—</td> <td>(25)</td> <td>(35)</td> </tr> <tr> <td rowspan="5">COLOR CHROMATICITY (CENTER)</td> <td>WHITE</td> <td>(0.26) (0.27)</td> <td>(0.31) (0.32)</td> <td>(0.36) (0.37)</td> </tr> <tr> <td>RED</td> <td>(0.59) (0.27)</td> <td>(0.64) (0.32)</td> <td>(0.69) (0.37)</td> </tr> <tr> <td>GREEN</td> <td>(0.23) (0.54)</td> <td>(0.28) (0.59)</td> <td>(0.33) (0.64)</td> </tr> <tr> <td>BLUE</td> <td>(0.08) (0.05)</td> <td>(0.14) (0.10)</td> <td>(0.18) (0.15)</td> </tr> <tr> <td>THE BRIGHTNESS OF MODULE (CENTER)</td> <td>(1250)</td> <td>(1350)</td> <td>—</td> </tr> </tbody> </table> <table border="1" data-bbox="1011 488 1391 835"> <thead> <tr> <th>ITEM</th> <th>MIN.</th> <th>TYP.</th> <th>MAX.</th> </tr> </thead> <tbody> <tr> <td rowspan="4">VIEWING ANGLE</td> <td>80</td> <td>85</td> <td>—</td> </tr> <tr> <td>80</td> <td>85</td> <td>—</td> </tr> <tr> <td>80</td> <td>85</td> <td>—</td> </tr> <tr> <td>80</td> <td>85</td> <td>—</td> </tr> <tr> <td>CONTRAST RATIO (CENTER)</td> <td>700</td> <td>1000</td> <td>—</td> </tr> <tr> <td>RESPONSE TIME</td> <td>—</td> <td>25</td> <td>35</td> </tr> <tr> <td rowspan="5">COLOR CHROMATICITY (CENTER)</td> <td>WHITE</td> <td>0.27 0.32</td> <td>0.32 0.37</td> <td>0.37 0.42</td> </tr> <tr> <td>RED</td> <td>0.59 0.28</td> <td>0.64 0.33</td> <td>0.69 0.38</td> </tr> <tr> <td>GREEN</td> <td>0.25 0.61</td> <td>0.30 0.66</td> <td>0.35 0.71</td> </tr> <tr> <td>BLUE</td> <td>0.09 0.05</td> <td>0.14 0.10</td> <td>0.19 0.15</td> </tr> <tr> <td>THE BRIGHTNESS OF MODULE (CENTER)</td> <td>1250</td> <td>1350</td> <td>—</td> </tr> </tbody> </table>	ITEM	MIN.	TYP.	MAX.	VIEWING ANGLE	(80)	(85)	—	(80)	(85)	—	(80)	(85)	—	(80)	(85)	—	CONTRAST RATIO (CENTER)	(700)	(1000)	—	RESPONSE TIME	—	(25)	(35)	COLOR CHROMATICITY (CENTER)	WHITE	(0.26) (0.27)	(0.31) (0.32)	(0.36) (0.37)	RED	(0.59) (0.27)	(0.64) (0.32)	(0.69) (0.37)	GREEN	(0.23) (0.54)	(0.28) (0.59)	(0.33) (0.64)	BLUE	(0.08) (0.05)	(0.14) (0.10)	(0.18) (0.15)	THE BRIGHTNESS OF MODULE (CENTER)	(1250)	(1350)	—	ITEM	MIN.	TYP.	MAX.	VIEWING ANGLE	80	85	—	80	85	—	80	85	—	80	85	—	CONTRAST RATIO (CENTER)	700	1000	—	RESPONSE TIME	—	25	35	COLOR CHROMATICITY (CENTER)	WHITE	0.27 0.32	0.32 0.37	0.37 0.42	RED	0.59 0.28	0.64 0.33	0.69 0.38	GREEN	0.25 0.61	0.30 0.66	0.35 0.71	BLUE	0.09 0.05	0.14 0.10	0.19 0.15	THE BRIGHTNESS OF MODULE (CENTER)	1250	1350	—
ITEM	MIN.	TYP.	MAX.																																																																																											
VIEWING ANGLE	(80)	(85)	—																																																																																											
	(80)	(85)	—																																																																																											
	(80)	(85)	—																																																																																											
	(80)	(85)	—																																																																																											
CONTRAST RATIO (CENTER)	(700)	(1000)	—																																																																																											
RESPONSE TIME	—	(25)	(35)																																																																																											
COLOR CHROMATICITY (CENTER)	WHITE	(0.26) (0.27)	(0.31) (0.32)	(0.36) (0.37)																																																																																										
	RED	(0.59) (0.27)	(0.64) (0.32)	(0.69) (0.37)																																																																																										
	GREEN	(0.23) (0.54)	(0.28) (0.59)	(0.33) (0.64)																																																																																										
	BLUE	(0.08) (0.05)	(0.14) (0.10)	(0.18) (0.15)																																																																																										
	THE BRIGHTNESS OF MODULE (CENTER)	(1250)	(1350)	—																																																																																										
ITEM	MIN.	TYP.	MAX.																																																																																											
VIEWING ANGLE	80	85	—																																																																																											
	80	85	—																																																																																											
	80	85	—																																																																																											
	80	85	—																																																																																											
CONTRAST RATIO (CENTER)	700	1000	—																																																																																											
RESPONSE TIME	—	25	35																																																																																											
COLOR CHROMATICITY (CENTER)	WHITE	0.27 0.32	0.32 0.37	0.37 0.42																																																																																										
	RED	0.59 0.28	0.64 0.33	0.69 0.38																																																																																										
	GREEN	0.25 0.61	0.30 0.66	0.35 0.71																																																																																										
	BLUE	0.09 0.05	0.14 0.10	0.19 0.15																																																																																										
	THE BRIGHTNESS OF MODULE (CENTER)	1250	1350	—																																																																																										
	13	<p>8.2 CTP MODULE</p> 																																																																																												
	16	<p>10.3 CTP INTERFACE (IF)</p> <table border="1" data-bbox="596 1568 1077 1668"> <thead> <tr> <th>PIN NO.</th> <th>SYMBOL</th> <th>PIN NO.</th> <th>SYMBOL</th> </tr> </thead> <tbody> <tr> <td>1</td> <td>VCC</td> <td>1</td> <td>VDD1</td> </tr> <tr> <td>3</td> <td>INT</td> <td>3</td> <td>/INT</td> </tr> <tr> <td>6</td> <td>GND</td> <td>6</td> <td>VSS1</td> </tr> <tr> <td>7</td> <td>GND</td> <td>7</td> <td>VSS1</td> </tr> </tbody> </table>	PIN NO.	SYMBOL	PIN NO.	SYMBOL	1	VCC	1	VDD1	3	INT	3	/INT	6	GND	6	VSS1	7	GND	7	VSS1																																																																								
PIN NO.	SYMBOL	PIN NO.	SYMBOL																																																																																											
1	VCC	1	VDD1																																																																																											
3	INT	3	/INT																																																																																											
6	GND	6	VSS1																																																																																											
7	GND	7	VSS1																																																																																											
	17	<p>11.1 POWER SUPPLY FOR LCM</p> 																																																																																												

RECORDS OF REVISION	DOC . FIRST ISSUE	MAR.29, 2023
---------------------	-------------------	--------------

DATE	REVISED PAGE NO.	SUMMARY								
SEP.20, 2024	18	12.1 OPTICAL CHARACTERISTICS <table border="1"> <tr> <td>ITEM</td> <td>MIN.</td> <td>ITEM</td> <td>MIN.</td> </tr> <tr> <td>TRANSPARENCY NOTE (1)</td> <td>(85)</td> <td>TRANSPARENCY NOTE (1)</td> <td>85</td> </tr> </table>	ITEM	MIN.	ITEM	MIN.	TRANSPARENCY NOTE (1)	(85)	TRANSPARENCY NOTE (1)	85
	ITEM	MIN.	ITEM	MIN.						
	TRANSPARENCY NOTE (1)	(85)	TRANSPARENCY NOTE (1)	85						
			12.2 HARDNESS <table border="1"> <tr> <td>ITEM</td> <td>DESCRIPTION</td> <td>ITEM</td> <td>DESCRIPTION</td> </tr> <tr> <td>SURFACE HARDNESS</td> <td>(7H) (min)</td> <td>SURFACE HARDNESS</td> <td>7H(min)</td> </tr> </table>	ITEM	DESCRIPTION	ITEM	DESCRIPTION	SURFACE HARDNESS	(7H) (min)	SURFACE HARDNESS
ITEM	DESCRIPTION	ITEM	DESCRIPTION							
SURFACE HARDNESS	(7H) (min)	SURFACE HARDNESS	7H(min)							
		ADD 12.4 HOVER FUNCTION								
	19	ADD 12.5.3 I2C COMMAND EXAMPLE								
	26	14.1 STANDARD SPECIFICATIONS FOR RELIABILITY OF LCD MODULE NOTE(2):WHEN THE LCD MODULE IS OPERATED AT AMBIENT TEMPERATURE 80°C, THE PWM DUTY CYCLE OF THE LED BACKLIGHT SHOULD BE ADJUSTED TO BE LESS THAN TBD. IF THE MODULE IS OPERATED AT A HIGHER DUTY CYCLE THAN TBD, THEN THERE IS A POSSIBILITY OF DISTORTION AND IRREGULARITY OF THE PICTURE DUE TO LIQUID CRYSTAL BEHAVIOR. →WHEN THE LCD MODULE IS OPERATED AT AMBIENT TEMPERATURE 80°C, THE PWM DUTY CYCLE OF THE LED BACKLIGHT SHOULD BE ADJUSTED TO BE LESS THAN 30%. IF THE MODULE IS OPERATED AT A HIGHER DUTY CYCLE THAN 40%, THEN THERE IS A POSSIBILITY OF DISTORTION AND IRREGULARITY OF THE PICTURE DUE TO LIQUID CRYSTAL BEHAVIOR.								
DEC.03, 2024	4	4.1 LCD MODULE ELECTRICAL CHARACTERISTICS ITEM:RUSH CURRENT, MAX.=(1.5)→1.5 ITEM: ALLOWABLE LOGIC/LCD DRIVE RIPPLE VOLTAGE, MAX.=(200)→200								
	5	4.2 CAPACITIVE TOUCH PANEL ELECTRICAL CHARACTERISTICS ITEM: INPUT HIGH-LEVEL VOLTAGE, MAX.=VCC→VDD1								
	12	7. OUTLINE DIMENSIONS MARK△ : MODIFY NOTE 1. DELETE PROTECT FILM								

TABLE OF CONTENTS

NO.	ITEM	PAGE
1.	GENERAL SPECIFICATIONS -----	1
2.	MECHANICAL SPECIFICATIONS -----	1, 2
3.	ABSOLUTE MAXIMUM RATINGS -----	3
4.	ELECTRICAL CHARACTERISTICS -----	4, 5
5.	TIMING CHARACTERISTICS -----	6 ~ 9
6.	OPTICAL CHARACTERISTICS -----	10, 11
7.	OUTLINE DIMENSIONS -----	12
8.	BLOCK DIAGRAM -----	13
9.	DETAIL DRAWING OF DOT MATRIX -----	14
10.	INTERFACE SIGNALS -----	15, 16
11.	POWER SUPPLY -----	17
12.	CAPACITIVE TOUCH PANEL SPECIFICATION -----	18, 19
13.	INSPECTION CRITERIA -----	20 ~ 25
14.	RELIABILITY TEST -----	26
15.	CAUTION -----	27, 28

CONFIDENTIAL
Authorized for Emerging Display Technologies Corporation Only.
Do not distribute without authorization.

1. GENERAL SPECIFICATIONS

1.1 DATA SHEETS FOR TFT MODULE CONTROLLER/DRIVER

PLEASE REFER TO :

HX-8255B

1.2 APPLICATION NOTES FOR CAPACITIVE TOUCH PANEL CONTROLLER/DRIVER

PLEASE REFER TO :

TOUCHNETIX AX112A

1.3 MATERIAL SAFETY DESCRIPTION

ASSEMBLIES SHALL COMPLY WITH EUROPEAN ROHS REQUIREMENTS, INCLUDING PROHIBITED MATERIALS/COMPONENTS CONTAINING LEAD, MERCURY, CADMIUM, HEXAVALENT CHROMIUM, POLYBROMINATED BIPHENYLS (PBB) AND POLYBROMINATED DIPHENYL ETHERS (PBDE), BIS(2-ETHYLHEXYL) PHTHALATE (DEHP), BUTYL BENZYL PHTHALATE (BBP), DIBUTYL PHTHALATE (DBP), DIISOBUTYL PHTHALATE (DIBP).

2. MECHANICAL SPECIFICATIONS

2.1 LCD MODULE MECHANICAL SPECIFICATIONS

- (1) DIAGONALS ----- 15.6 inch
- (2) NUMBER OF DOTS ----- 1920W(RGB) * 1080H DOTS
- (3) MODULE SIZE ----- 363.8W * 215.9H * 16.55D(MAX.) mm
(WITHOUT FPC)
- (4) VIEWING AREA ----- 374.16W * 196.59H mm
- (5) ACTIVE AREA ----- 344.16W * 193.59H mm
- (6) DOT SIZE ----- 0.05975W * 0.17925H mm
- (7) PIXEL SIZE ----- 0.17925W * 0.17925H mm
- (8) LCD TYPE ----- TFT, IPS, TRANSMISSIVE,
NORMALLY BLACK
- (9) COLOR ----- 16.7M
- (10) VIEWING DIRECTION ----- SUPER WIDE VIEW
- (11) BACK LIGHT ----- LED , COLOR : WHITE
- (12) INTERFACE MODE ----- LVDS(VESA)
- (13) WEIGHT ----- 1213g

MODEL NO.	VERSION	PAGE
ETML156025LDYA	3	2

2.2 CAPACITIVE TOUCH PANEL MECHANICAL SPECIFICATIONS

- (1) TOUCH PANEL SIZE ----- 15.6 inch
- (2) OUTER DIMENSION ----- 361.8W * 213.9H * 2.4D mm
(WITHOUT FPC)
- (3) ACTIVE AREA ----- 346.16W * 195.59H mm
- (4) INPUT TYPE ----- TOUCH : MULTI POINT
HOVER : SINGLE POINT
- (5) NUMBER OF TOUCH SENSOR ----- 48*27 SENSORS
- (6) RESOLUTION ----- 65536*65536
- (7) INTERFACE MODE ----- I2C

CONFIDENTIAL
Authorized for
Emerging Display Technologies Corporation Only.
Do not distribute without authorization.

3. ABSOLUTE MAXIMUM RATINGS

3.1 TFT MODULE ELECTRICAL ABSOLUTE MAXIMUM RATINGS

ITEM	SYMBOL	MIN.	MAX.	UNIT	REMARK
POWER SUPPLY VOLTAGE	VDD-VSS	-0.3	4.0	V	
POWER SUPPLY VOLTAGE FOR LED DRIVER	VBL+-VSS	-0.3	27	V	

3.2 CAPACITIVE TOUCH PANEL ELECTRICAL ABSOLUTE MAXIMUM RATINGS

ITEM	SYMBOL	MIN.	MAX.	UNIT	REMARK
POWER SUPPLY FOR DRIVER	VDD1-VSS1	-0.3	4	V	

3.3 ENVIRONMENTAL ABSOLUTE MAXIMUM RATINGS

ITEM	OPERATING		STORAGE		REMARK
	MIN.	MAX.	MIN.	MAX.	
AMBIENT TEMPERATURE	-30°C	85°C	-30°C	85°C	NOTE (1), (2), (3), (4)
HUMIDITY	NOTE (3)		NOTE (3)		WITHOUT CONDENSATION
VIBRATION	—	2.45 m/s ² (0.25 G)	—	11.76m/s ² (1.2 G)	10~100 Hz XYZ DIRECTIONS 1 HR EACH
SHOCK	—	29.4 m/s ² (3 G)	—	490.0 m/s ² (50 G)	10 ms XYZ DIRECTIONS 1 TIME EACH
CORROSIVE GAS	NOT ACCEPTABLE		NOT ACCEPTABLE		

NOTE (1) : THE ABSOLUTE MAXIMUM RATINGS OF THIS PRODUCT SHOULD NOT BE EXCEEDED AT ANY TIME. IF THESE RATINGS ARE EXCEEDED, THE PRODUCT'S PERFORMANCE IS NOT GUARANTEED AND THE PRODUCT MAY EXPERIENCE PERMANENT DAMAGE.

NOTE (2) : BACKGROUND COLOR CHANGES SLIGHTLY DEPENDING ON AMBIENT TEMPERATURE THIS PHENOMENON IS REVERSIBLE.

NOTE (3) : Ta ≤ 40°C : 90%RH MAX. (96HRS MAX).

Ta > 40°C : ABSOLUTE HUMIDITY MUST BE LOWER THAN THE HUMIDITY OF 90%RH AT 40°C (96HRS MAX).

NOTE (4) : WHEN THE LCD MODULE IS OPERATED AT AMBIENT TEMPERATURE 80°C, THE PWM DUTY CYCLE OF THE LED BACKLIGHT SHOULD BE ADJUSTED TO BE LESS THAN 30%. IF THE MODULE IS OPERATED AT A HIGHER DUTY CYCLE THAN 30%, THEN THERE IS A POSSIBILITY OF DISTORTION AND IRREGULARITY OF THE PICTURE DUE TO LIQUID CRYSTAL BEHAVIOR.

4. ELECTRICAL CHARACTERISTICS

4.1 LCD MODULE ELECTRICAL CHARACTERISTICS

Ta = 25 °C

ITEM	SYMBOL	CONDITION	MIN.	TYP.	MAX.	UNIT	REMARK
POWER SUPPLY VOLTAGE	VDD-VSS	—	3.15	3.3	3.45	V	
RUSH CURRENT	I _{Rush}	—	—	—	1.5	A	NOTE (4)
ALLOWABLE LOGIC/LCD DRIVE RIPPLE VOLTAGE	V _{VDD-RP}	—	—	—	200	mV	NOTE (3)
POWER SUPPLY CURRENT	IDD	VDD-VSS = 3.3V	—	350	454	mA	NOTE (1)
POWER SUPPLY VOLTAGE FOR LED DRIVER	VBL+-VBL-	—	10.8	12	13.2	V	NOTE (2)
POWER SUPPLY VOLTAGE FOR LED DRIVER	BL_PWM	V _{IH}	1.6	—	—	V	
		V _{IL}	—	—	0.8	V	
	BL_EN	V _{IH}	1.6	—	—	V	
		V _{IL}	—	—	0.8	V	
POWER SUPPLY CURRENT FOR LED DRIVER	IBL+	VBL+-VBL- = 12V LED B/L=ON PWM=100%	—	2	2.6	A	
LED LIFE TIME	—	IF=60mA (PER LED)	50K	—	—	HRS	NOTE (5) NOTE (6)

NOTE (1) : THE DISPLAY PATTERN IS ALL “WHITE”.

NOTE (2) : INTERNAL CIRCUIT DIAGRAM OF BACKLIGHT

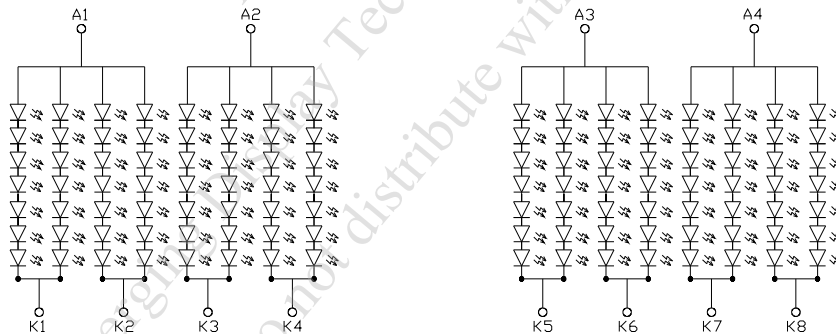

NOTE (3) : THE SPECIFIED V_{CC} CURRENT AND POWER CONSUMPTION ARE MEASURED UNDER THE V_{DD} = 3.3 V, F_V= 60 Hz CONDITION AND WHITE PATTERN.

NOTE (4) : THE FIGURES BELOW IS THE MEASURING CONDITION OF V_{DD}. RUSH CURRENT CAN BE MEASURED WHEN T_{RUSH} IS 0.5 ms.

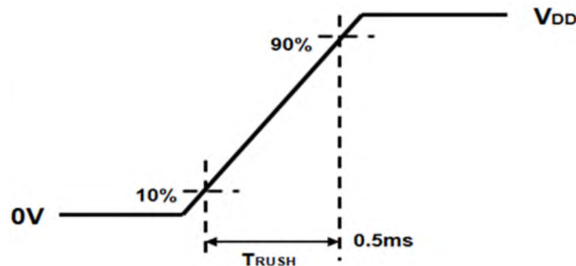

NOTE (5) : CONDITIONS; Ta=25 °C, CONTINUOUS LIGHTING

NOTE (6) : DEFINITIONS OF LIFE TIME :

4.2 CAPACITIVE TOUCH PANEL ELECTRICAL CHARACTERISTICS

Ta = 25°C

ITEM	SYMBOL	CONDITION	MIN.	TYP.	MAX.	UNIT
POWER SUPPLY FOR DRIVER	VDD1-VSS1	—	3.15	3.3	3.45	V
INPUT HIGH-LEVEL VOLTAGE	VIH	—	2	—	VDD1	V
INPUT LOW-LEVEL VOLTAGE	VIL	—	-0.3	—	0.8	V
OUTPUT HIGH-LEVEL VOLTAGE	VOH	—	2.4	—	—	V
OUTPUT LOW-LEVEL VOLTAGE	VOL	—	—	—	0.4	V
POWER SUPPLY CURRENT CONSUMPTION FOR OPERATION	IDD1	VDD1-VSS1 =3.3V	—	250	325	mA

CONFIDENTIAL
Authorized for
Emerging Display Technologies Corporation Only
Do not distribute without authorization.

5. TIMING CHARACTERISTICS

5.1 SIGNAL ELECTRICAL CHARACTERISTICS

5.1.1 SIGNAL ELECTRICAL CHARACTERISTICS FOR LVDS RECEIVER THE BUILT-IN LVDS RECEIVER IS COMPATIBLE WITH (ANSI/TIA/TIA-644) STANDARD.

LVDS RECEIVER ELECTRICAL CHARACTERISTICS

ITEM	SYMBOL	MIN.	TYP.	MAX.	UNIT	CONDITIONS
DIFFERENTIAL INPUT HIGH THRESHOLD	V_{th}	—	—	(+100)	mV	$V_{CM} = 1.2V$
DIFFERENTIAL INPUT LOW THRESHOLD	V_{tl}	(-100)	—	—	mV	$V_{CM} = 1.2V$
MAGNITUDE DIFFERENTIAL INPUT VOLTAGE	$ V_{ID} $	(150)	—	(600)	mV	
COMMON MODE VOLTAGE	V_{CM}	(0.7)	—	(1.6)	V	

NOTE (1) : INPUT SIGNALS SHALL BE LOW OR HI- RESISTANCE STATE WHEN VDD IS OFF.

NOTE (2) : ALL ELECTRICAL CHARACTERISTICS FOR LVDS SIGNAL ARE DEFINED AND SHALL BE MEASURED AT THE INTERFACE CONNECTOR OF LCD.

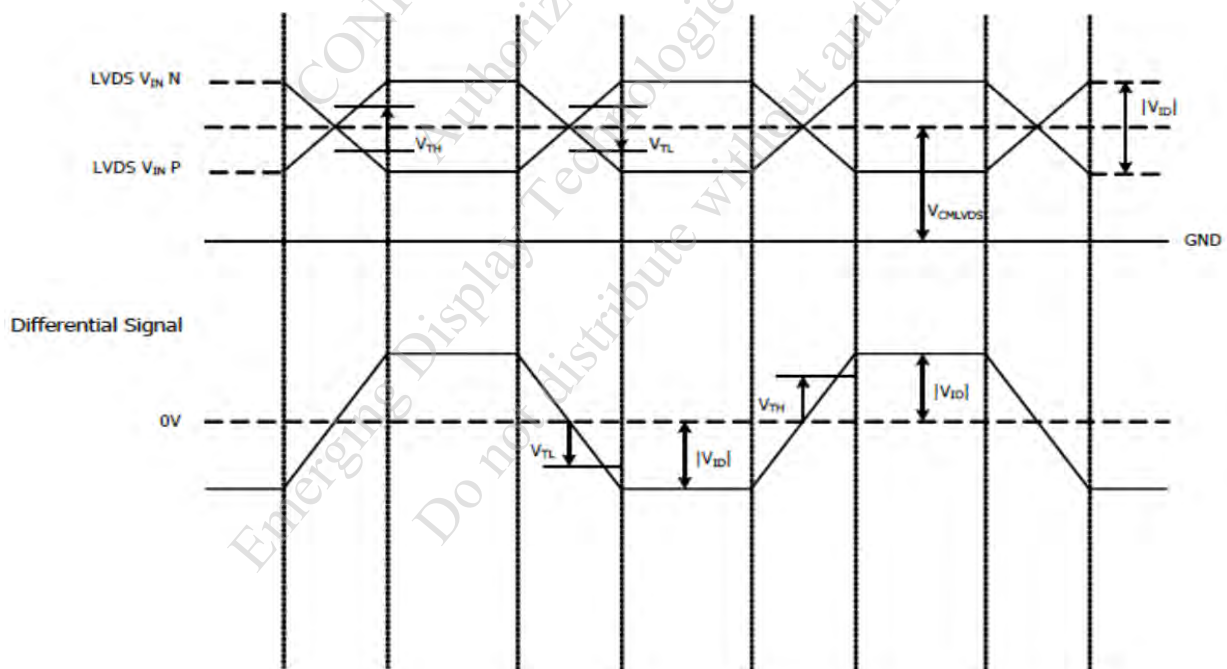

VOLTAGE DEFINITIONS

LVDS AC ELECTRICAL CHARACTERISTICS

ITEM	SYMBOL	MIN.	TYP.	MAX.	UNIT	CONDITIONS
CLOCK PERIOD	TLVCP	—	(T)	—	ns	
CLOCK HIGH TIME	TLVCH	—	(4T/7)	—	ns	
CLOCK LOW TIME	TLVCL	—	(3T/7)	—	ns	

NOTE : $T = 1/F_{clk}$

5.1.2 LVDS INTERFACE DATA MAPPING

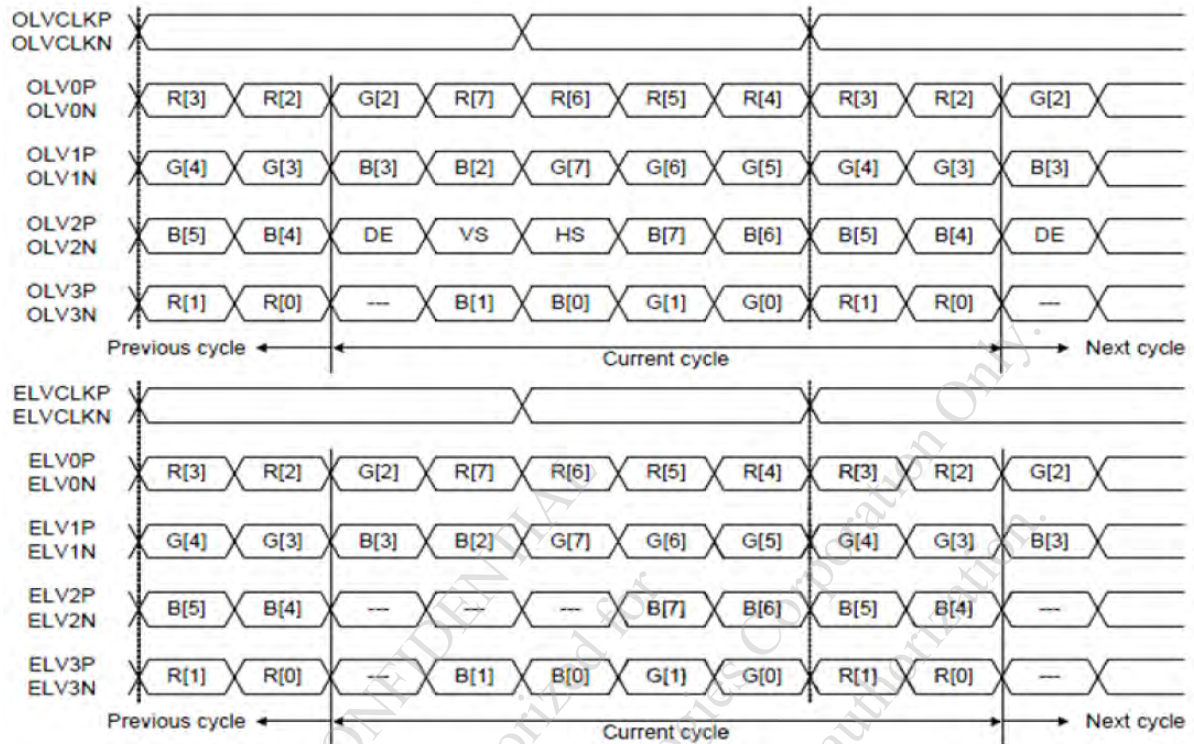

DATA MAPPING

5.2 LVDS RECEIVER INTERNAL CIRCUIT

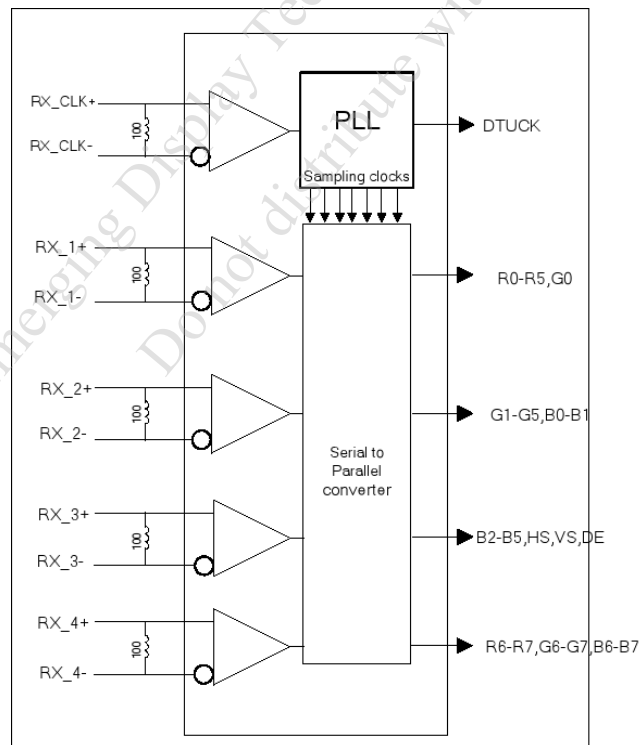

LVDS RECEIVER INTERNAL CIRCUIT

5.3 LVDS INTERFACE TIMING

ITEM	SYMBOL	MIN.	TYP.	MAX.	UNIT	REMARK
LVDS CLOCK FREQUENCY	Fclk	(69.5)	(70.5)	(73)	Mhz	
V TOTAL TIME	VT	(1104)	(1116)	(1080+A)	Clocks	
V ACTIVE TIME	VA	1080			—	
H TOTAL TIME	HT	(1050)	(1052)	(1920+B)	Lines	
H ACTIVE TIME	HA	1920			—	
FRAME RATE	FV	—	(60)	—	Hz	

NOTE (1) : SSC CAN ONLY BE DRIVEN TO 2%

NOTE (2) : THE MAXIMUM CLOCK FREQUENCY= $[(1920+B)*(1080+A)*60]<73\text{MHz}$

5.4 POWER SEQUENCE

INTERFACE SIGNALS ARE ALSO SHOWN IN THE CHART. SIGNALS FROM ANY SYSTEM SHALL BE HI- RESISTANCE STATE OR LOW LEVEL WHEN VDD VOLTAGE IS OFF.

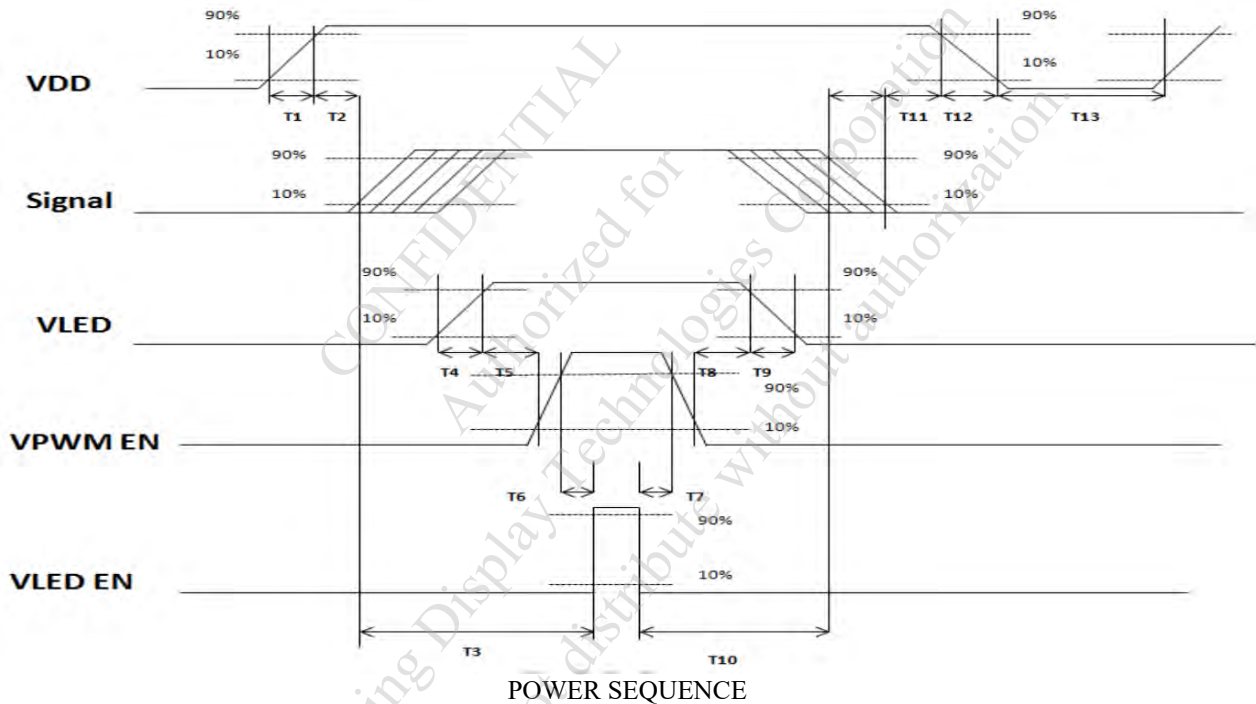

POWER SEQUENCING REQUIREMENTS

ITEM	MIN.	TYP.	MAX.	UNIT	REMARK
T1	(0.5)	—	(10)	ms	
T2	(30)	(40)	(50)	ms	
T3	(200)	—	—	ms	
T4	(0.5)	—	(10)	ms	
T5	(10)	—	—	ms	
T6	(10)	—	—	ms	
T7	(0)	—	—	ms	
T8	(10)	—	—	ms	
T9	—	—	(10)	ms	
T10	(110)	—	—	ms	
T11	(0)	(16)	(50)	ms	
T12	—	—	(10)	ms	
T13	(1000)	—	—	ms	

5.5 TOUCH PANEL TIMING

5.5.1 IC2 INTERFACE TIMING CHARACTERISTICS

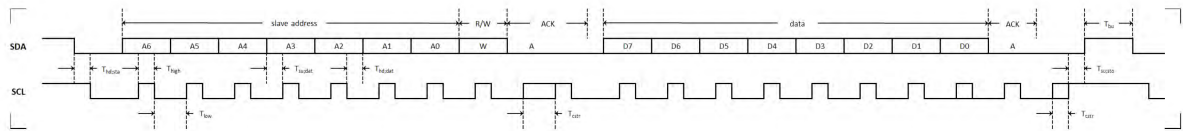

ITEM	SYMBOL	MIN.	MAX.	UNIT	REMARK
START BIT HOLD TIME	Thd;sta	600	—	ns	
CLOCK HIGH PERIOD	Thigh	600	—	ns	
CLOCK LOW PERIOD	Tlow	1300	—	ns	
DATA SETUP TIME	Tsu;dat	100	—	ns	
DATA HOLD TIME	Thd;dat	0	—	ns	
MAXIMUM CLOCK STRETCH BY SLAVE	Tcstr	—	5	us	
STOP BIT SETUP TIME	Tsu;sto	600	—	ns	
BUS FREE TIME BETWEEN STOP AND START	Tbu	1300	—	ns	

CONFIDENTIAL
Authorized for
Emerging Display Technologies Corporation Only
Do not distribute without authorization

6. OPTICAL CHARACTERISTICS

6.1 OPTICAL CHARACTERISTICS(NOTE 1)

Ta = 25 ± 2 °C

ITEM	SYMBOL	CONDITION	MIN.	TYP.	MAX.	UNIT	REMARK	
VIEWING ANGLE	θ_{y+}	CR ≥ 10	$\theta_x=0^\circ$	80	85	—	deg	NOTE (2) NOTE (3)
	θ_{y-}			80	85	—	deg	
	θ_{x+}		$\theta_y=0^\circ$	80	85	—	deg	
	θ_{x-}			80	85	—	deg	
CONTRAST RATIO (CENTER)	CR	$\theta_x=0^\circ, \theta_y=0^\circ$	700	1000	—	—	NOTE (3)	
RESPONSE TIME	TR+TF	$\theta_x=0^\circ, \theta_y=0^\circ$	—	25	35	msec	NOTE (4)	
COLOR CHROMATICITY (CENTER)	WHITE	Wx	$\theta_x=0^\circ, \theta_y=0^\circ$ VDD-VSS=3.3V VBL+ -VBL- =12V LED B/L=ON PWM=100%	0.27	0.32	0.37	—	NOTE (5)
		Wy		0.32	0.37	0.42		
	RED	Rx		0.59	0.64	0.69	—	
		Ry		0.28	0.33	0.38		
	GREEN	Gx		0.25	0.30	0.35	—	
		Gy		0.61	0.66	0.71		
	BLUE	Bx		0.09	0.14	0.19	—	
		By		0.05	0.10	0.15		
THE BRIGHTNESS OF MODULE (CENTER)	B		1250	1350	—	cd/m ²	NOTE (6)	
THE UNIFORMITY OF MODULE	—		70	—	—	%	NOTE (7)	

NOTE (1) : TEST CONDITION :

AFTER STABILIZING AND LEAVING THE PANEL ALONE AT A GIVEN TEMPERATURE FOR 30 MINUTES. MEASUREMENT SHOULD BE EXECUTED IN A STABLE, WINDLESS, AND DARK ROOM.

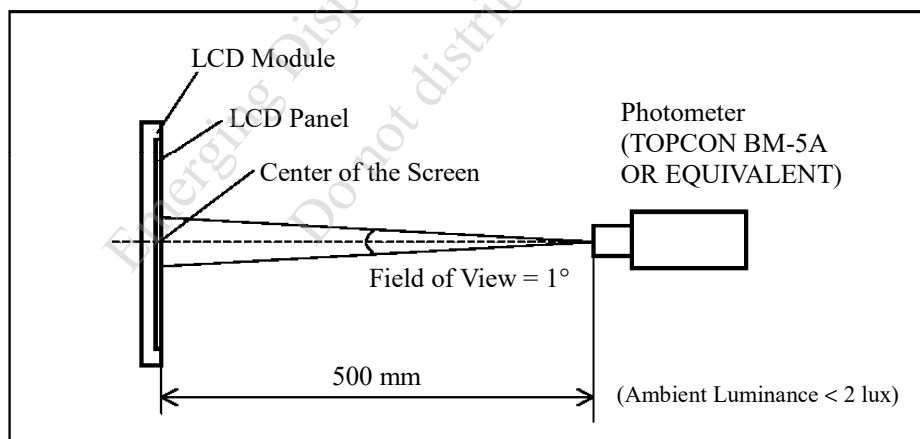

NOTE (2) : DEFINITION OF VIEWING ANGLE :

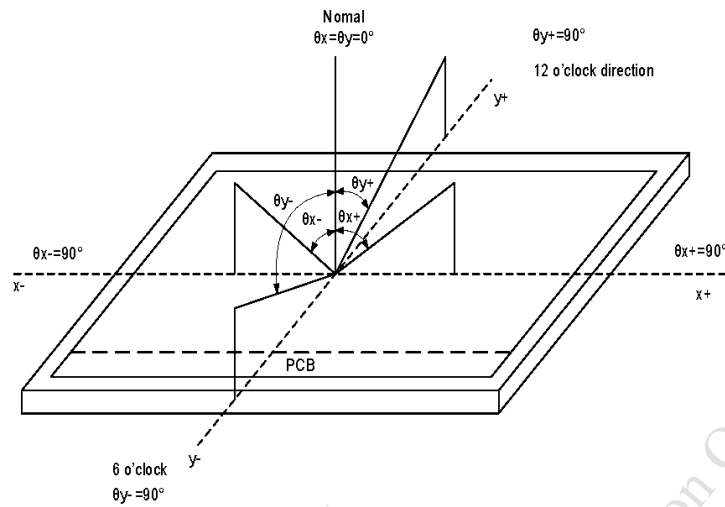

NOTE (3) : DEFINITION OF CONTRAST RATIO (CR) :
MEASURED AT THE CENTER POINT OF MODULE

$$\text{CONTRAST RATIO(CR)} = \frac{\text{BRIGHTNESS MEASURED WHEN LCD IS AT "WHITE STATE"}}{\text{BRIGHTNESS MEASURED WHEN LCD IS AT "BLACK STATE"}}$$

NOTE (4) : DEFINITION OF RESPONSE TIME : T_R AND T_F
THE FIGURE BELOW IS THE OUTPUT SIGNAL OF THE PHOTO DETECTOR.

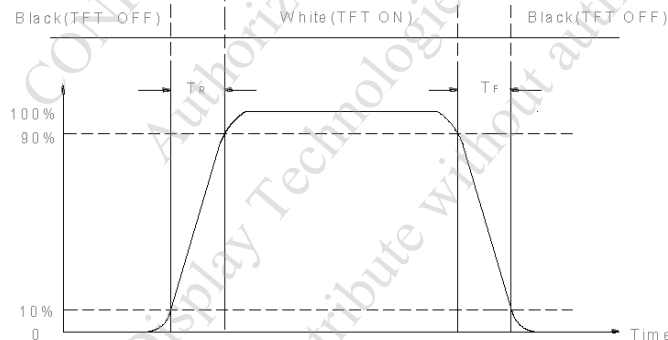

NOTE (5) : DEFINITION OF COLOR CHROMATICITY

(a) 100% RGB PIXEL DATA TRANSMISSION WHEN ALL THE INPUT TERMINALS OF MODULE ARE ELECTRICALLY POWERED ON.

(b) MEASURED AT THE CENTER POINT OF MODULE

NOTE (6) : MEASURED THE BRIGHTNESS OF WHITE STATE AT CENTER POINT.

NOTE (7) : (a) DEFINITION OF BRIGHTNESS UNIFORMITY

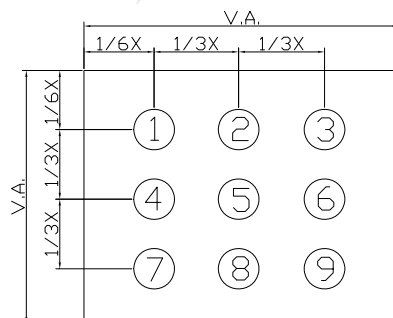

UNIT : mm

(b) THE BRIGHTNESS UNIFORMITY CALCULATING METHOD

$$\text{UNIFORMITY} : \frac{\text{MINIMUM BRIGHTNESS}}{\text{MAXIMUM BRIGHTNESS}} * 100\%$$

7. OUTLINE DIMENSIONS

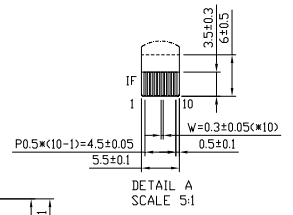
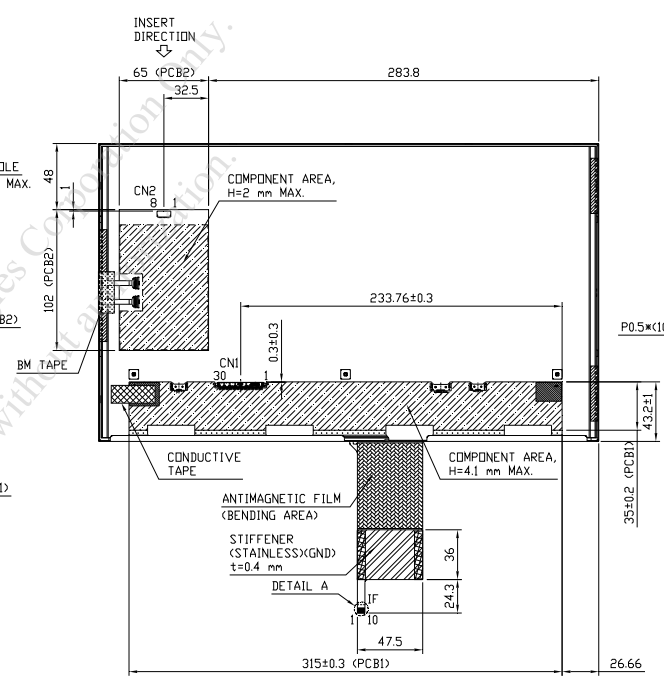
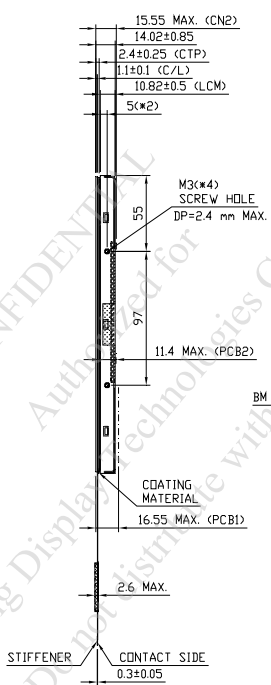
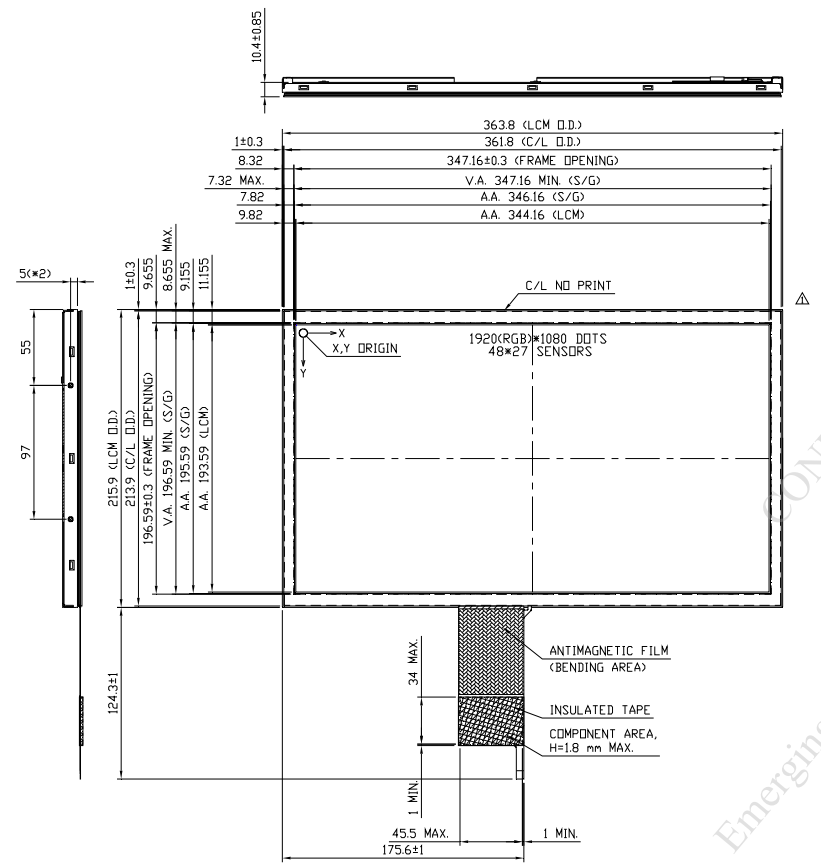

UNIT : mm
SCALE : NTS

THIRD ANGLE PROJECTION

NOT SPECIFIED TOLERANCE IS ± 0.5mm
NOTE : MARK Δ MODIFY (NUMBER NOTE MODIFY VERSION)
NOTE :

- Δ 1.C/L GLASS : SODA LIME, NON-STRENGTHEN, CHAMFERED EDGES.
- 2.CN1 : STM MSBKT2407P30HB OR EQUIVALENT.
- 3.CN2 : JST SM08B-SRSS-TB OR EQUIVALENT.
- 4.FPC BENDING RADIUS SHOULD BE MORE THAN 1.0 mm.

8. BLOCK DIAGRAM

8.1 LCD MODULE

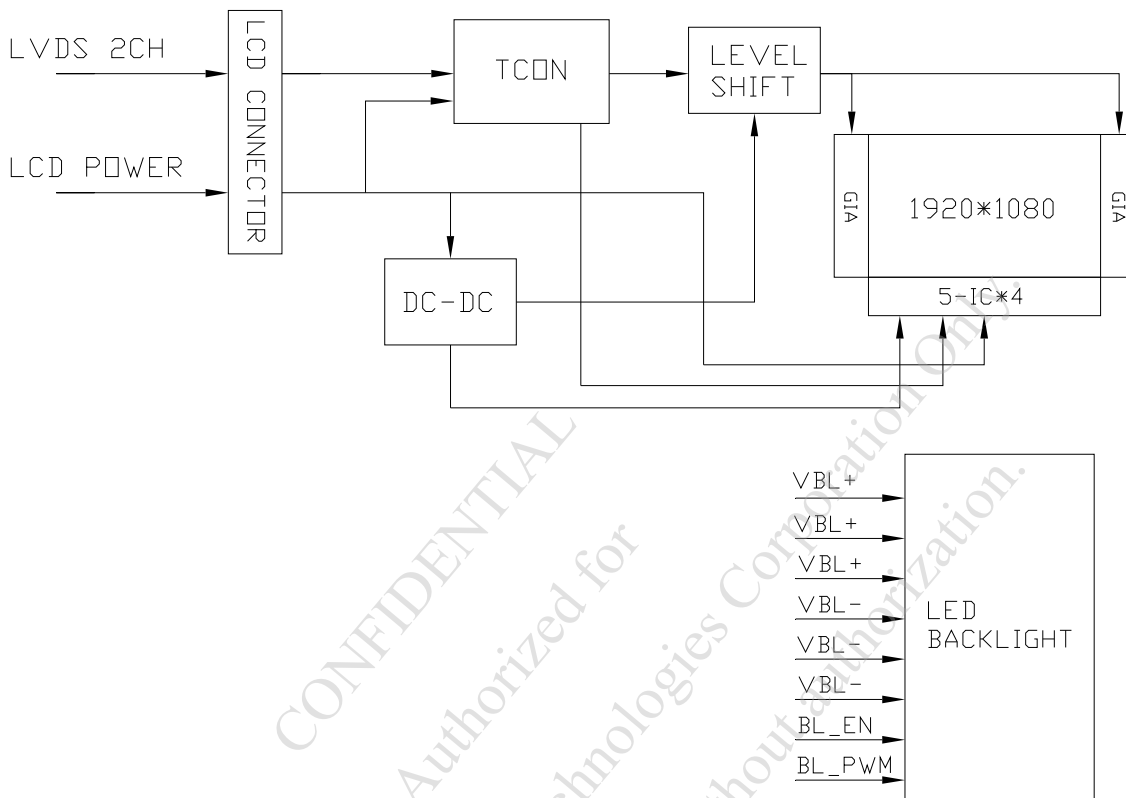

8.2 CTP MODULE

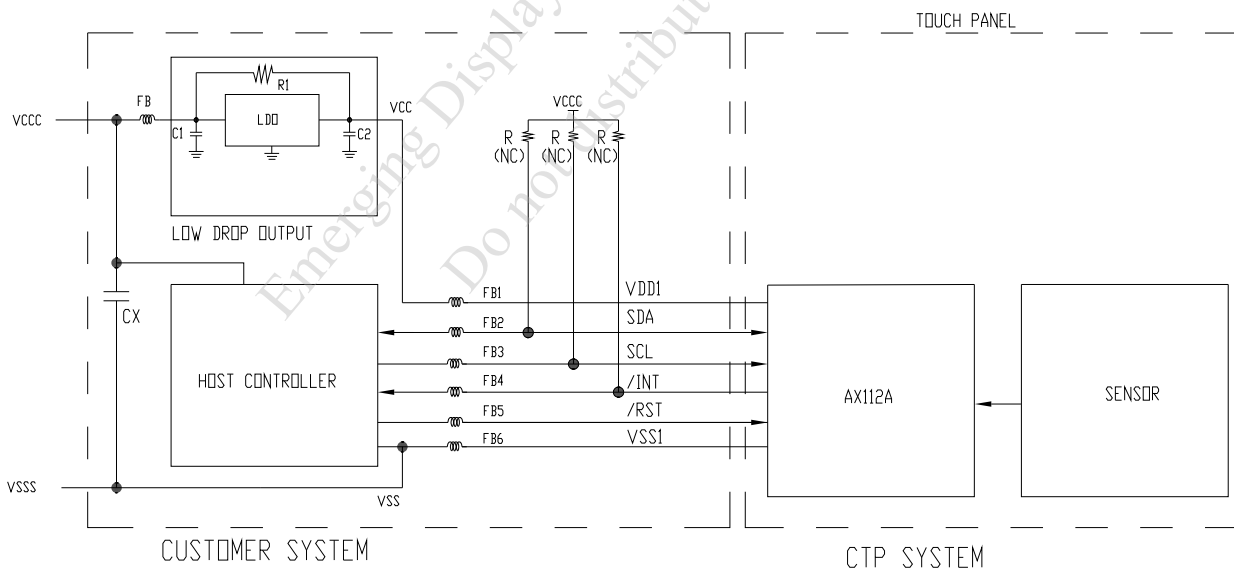

9. DETAIL DRAWING OF DOT MATRIX

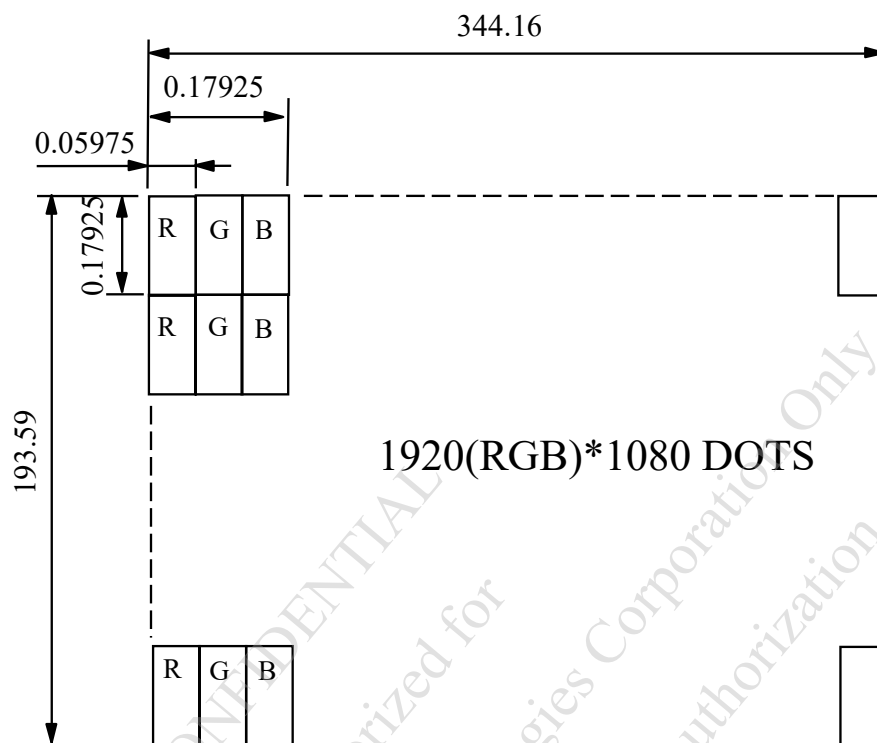

UNIT : mm
SCALE : NTS
NOT SPECIFIED TOLERANCE IS ± 0.1
DOTS MATRIX TOLERANCE IS ± 0.01

CONFIDENTIAL
Authorized for Emerging Display Technologies Corporation Only
Do not distribute without authorization

10. INTERFACE SIGNALS

10.1 LED MODULE INTERFACE(CN1)

PIN NO.	SYMBOL	FUNCTION	REMARKS
1	RxO0-	NEGATIVE LVDS DIFFERENTIAL DATA INPUT (ODD DATA)	
2	RxO0+	POSITIVE LVDS DIFFERENTIAL DATA INPUT (ODD DATA)	
3	RxO1-	NEGATIVE LVDS DIFFERENTIAL DATA INPUT (ODD DATA)	
4	RxO1+	POSITIVE LVDS DIFFERENTIAL DATA INPUT (ODD DATA)	
5	RxO2-	NEGATIVE LVDS DIFFERENTIAL DATA INPUT (ODD DATA)	
6	RxO2+	POSITIVE LVDS DIFFERENTIAL DATA INPUT (ODD DATA)	
7	VSS	GROUND	
8	RxOCLK-	NEGATIVE LVDS DIFFERENTIAL CLOCK INPUT (ODD CLOCK)	
9	RxOCLK+	POSITIVE LVDS DIFFERENTIAL CLOCK INPUT (ODD CLOCK)	
10	RxO3-	NEGATIVE LVDS DIFFERENTIAL DATA INPUT (ODD DATA)	
11	RxO3+	POSITIVE LVDS DIFFERENTIAL DATA INPUT (ODD DATA)	
12	RxE0-	NEGATIVE LVDS DIFFERENTIAL DATA INPUT (EVEN DATA)	
13	RxE0+	POSITIVE LVDS DIFFERENTIAL DATA INPUT (EVEN DATA)	
14	VSS	GROUND	
15	RxE1-	NEGATIVE LVDS DIFFERENTIAL DATA INPUT (EVEN DATA)	
16	RxE1+	POSITIVE LVDS DIFFERENTIAL DATA INPUT (EVEN DATA)	
17	VSS	GROUND	
18	RxE2-	NEGATIVE LVDS DIFFERENTIAL DATA INPUT (EVEN DATA)	
19	RxE2+	POSITIVE LVDS DIFFERENTIAL DATA INPUT (EVEN DATA)	
20	RxECLK-	NEGATIVE LVDS DIFFERENTIAL CLOCK INPUT (EVEN DATA)	
21	RxECLK+	POSITIVE LVDS DIFFERENTIAL CLOCK INPUT (EVEN DATA)	
22	RxE3-	NEGATIVE LVDS DIFFERENTIAL DATA INPUT (EVEN DATA)	
23	RxE3+	POSITIVE LVDS DIFFERENTIAL DATA INPUT (EVEN DATA)	
24	VSS	GROUND	
25	BIST	LCD PANEL SELF TEST ENABLE(3.3V TYP) FOR EDT USE, WHEN IT IS NOT USED, CONNECTING TO GND OR FLOATING IS RECOMMENDED	
26	SDA	I2C-COMPATIBLE SERIAL-DATA INPUT FOR EDT USE , FLOATING IS RECOMMENDED IN THE COSTUMER	
27	SCL	I2C-COMPATIBLE SERIAL-CLOCK INPUT FOR EDT USE , FLOATING IS RECOMMENDED IN THE COSTUMER	
28	VDD	POWER SUPPLY INPUT VOLTAGE(3.3V)	
29	VDD	POWER SUPPLY INPUT VOLTAGE(3.3V)	
30	VDD	POWER SUPPLY INPUT VOLTAGE(3.3V)	

10.2 LED MODULE INTERFACE(CN2)

PIN NO.	SYMBOL	FUNCTION
1	VBL+	POWER SUPPLY VOLTAGE FOR LED DRIVER(+)
2	VBL+	POWER SUPPLY VOLTAGE FOR LED DRIVER(+)
3	VBL+	POWER SUPPLY VOLTAGE FOR LED DRIVER(+)
4	VBL-	POWER SUPPLY VOLTAGE FOR LED DRIVER(-)
5	VBL-	POWER SUPPLY VOLTAGE FOR LED DRIVER(-)
6	VBL-	POWER SUPPLY VOLTAGE FOR LED DRIVER(-)
7	BL_EN	BACKLIGHT LED ON/OFF CONTROL
8	BL_PWM	BACKLIGHT LED BRIGHTNESS CONTROL

10.3 CTP INTERFACE (IF)

PIN NO.	SYMBOL	DESCRIPTION
1	VDD1	POWER SUPPLY VOLTAGE FOR INTERFACE (+3.3V)
2	/RST	RESET PIN
3	/INT	EXTERNAL INTERRUPT TO THE HOST
4	SDA	I2C DATA INPUT AND OUTPUT
5	SCL	I2C CLOCK INPUT
6	VSS1	GROUND
7	VSS1	GROUND
8	NC	NON CONNECTION
9	NC	NON CONNECTION
10	NC	NON CONNECTION

11. POWER SUPPLY

11.1 POWER SUPPLY FOR LCM

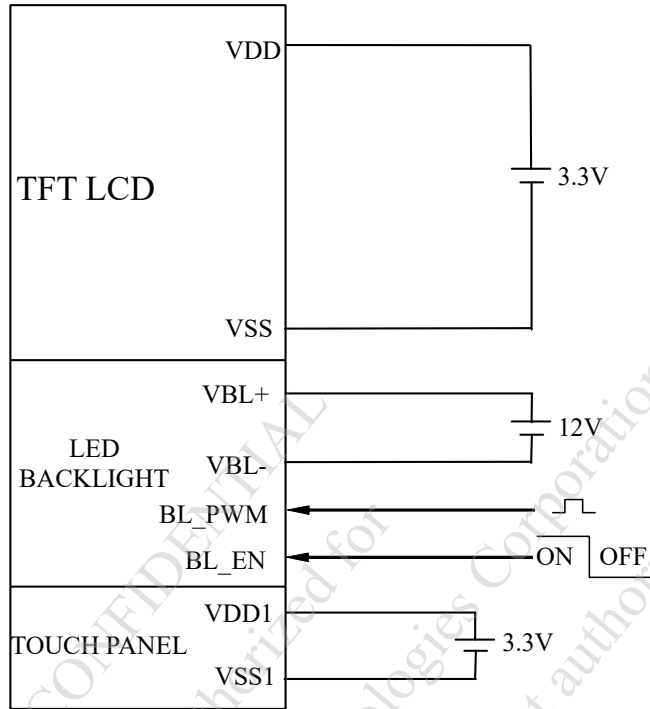

NOTE (1) : ADJUST THE PWM SIGNAL IN ORDER TO CONTROL LED BACKLIGHT'S BRIGHTNESS. THE HIGHER THE DUTY CYCLE, THE HIGHER THE BRIGHTNESS

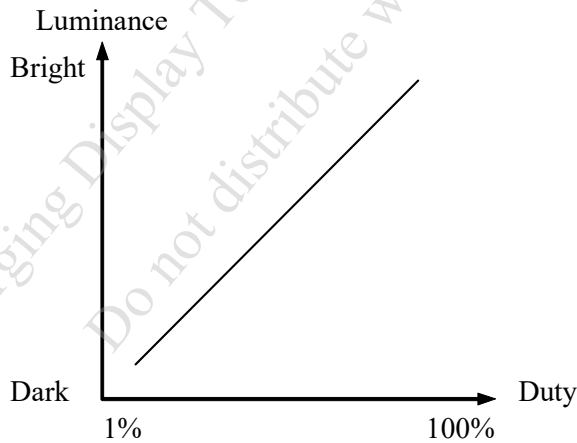

NOTE (2) : PWM SIGNAL OPERATION FREQUENCY IS 100~2000 Hz AND DIMMING DUTY.

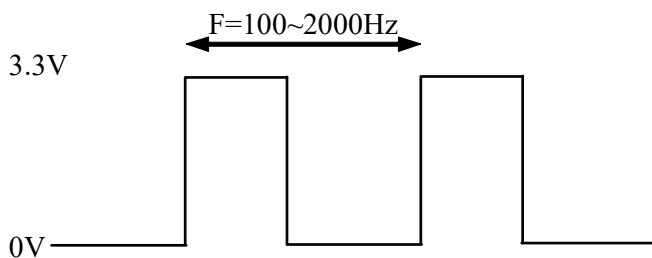

PWM Dimming Frequency[Hz]	Dimming Duty	
	Min[%]	Max[%]
$100 < F_{DIM} < 200$	0.1	100
$200 < F_{DIM} < 500$	0.4	100
$500 < F_{DIM} < 1K$	0.8	100
$1K < F_{DIM} < 2K$	1.5	100

12. CAPACITIVE TOUCH PANEL SPECIFICATION

12.1 OPTICAL CHARACTERISTICS

ITEM	CONDITION	MIN.	TYP.	MAX.	UNIT
TRANSPARENCY NOTE (1)	Ta = 25°C λ=550nm	85	—	—	%

NOTE (1) : OPTICAL MEASUREMENT SHOULD BE EXECUTED AFTER PANEL IS SECURED.
MEASUREMENT PROCESS SHOULD BE EXECUTED IN A STABLE, WINDLESS,
AND DARK ROOM.
OPTICAL SPECIFICATIONS SHOULD BE MEASURED BY SPECTROPHOTOMETER.

12.2 HARDNESS

ITEM	DESCRIPTION
SURFACE HARDNESS	7H(min)

12.3 DURABILITY

USING STEEL BALL AND FALLING ON TOUCH PANEL SURFACE, FROM THE HEIGHT MUST PASS BELOW CONDITIONS :

ITEM	CONDITION	INSPECTION METHOD	DESCRIPTION
STEEL BALL DROP TEST	WEIGHT : 67g HEIGHT OF FALL : 30 cm	VISUAL INSPECTION	EXPLOSION-PROOF

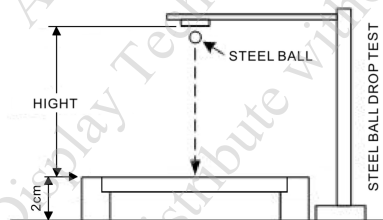

12.4 HOVER FUNCTION

DETECTION AXIS		X, Y, Z
FINGER DETECTION RANGE		X/Y AXIS: SENSOR GLASS A.A. FOUR-SIDED RETRACTION 20mm
ACCURACY	@HEIGHT <4.5cm (EDGE)	±20mm
	@HEIGHT <5.0cm (CENTER)	
NUMBER OF DETECTION		1 FINGER (Φ15mm)

12.5 I2C BUS PROTOCOL

IN THE FOLLOWING DIAGRAMS ADDR IS THE 7-BITI2C BUS ADDRESS,
START/STOP ARE THE NORMAL BUS START AND STOP CONDITIONS
RESPECTIVELY, WR DENOTES THAT THE 8TH BIT OF THE ADDRESS BYTE IS
CLEAR TO REQUEST A WRITE TRANSFER WHEREAS RD DENOTES THAT IT IS
SET TO REQUEST A READ TRANSFER. THE DEVICE WILL APPLY A CLOCK
STRETCH WHEN IT NEEDS TO DECODE OR PREPARE DATA BETWEEN THE
VARIOUS PHASES.

12.5.1 DATA FROM DEVICE TO HOST (READ)

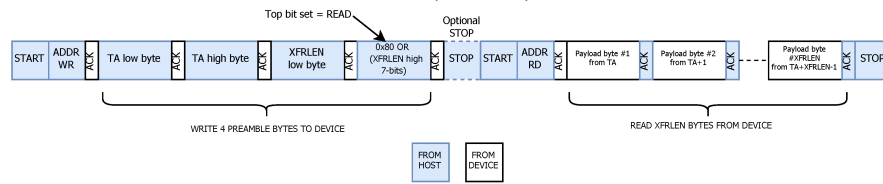

I2C READ TRANSFER

12.5.2 DATA FROM HOST TO DEVICE (WRITE)

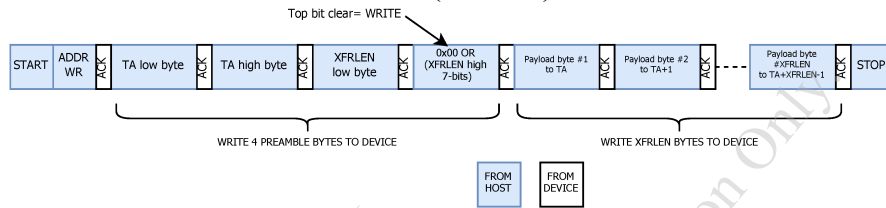

I2C WRITE TRANSFER

SLAVE I2C ADDRESS=0x66

12.5.3 I2C COMMAND EXAMPLE

```
Start, CC [ 66 | WR ], 00, 08, 3A, 80, Stop
0x00, 0x08 = 0x0800 (Target Address U34)
0x3A=58 (Total length of U41)
0x80= Axiom I2C read command
Start, CD [ 66 | RD ], 1D, 41, 01, 00, 64, B2, C4, A4,
00, 00, 00, 00, 00, 00, 00, 00, 00, 00, 00, 00, 00, 00, 00, 00,
00, 00, 00, 00, 00, 00, 00, 00, 00, 00, 00, 00, 00, 00, 00,
00, 00, 00, 00, 00, 00, 00, 00, 00, 00, 00, 00, 00, 00, 00,
00, 00, 00, 00, 22, 57, 9F, 7F NAK, Stop
```

0x1D=29 (word length. 19*2=58, so they are total 58 bytes)
0x41= U41

Look up U41 table:
01, 00, = 0x0001 (One finger touch on the TP)
64, B2, = 0xB264 (X0 coordinate)
C4, A4, = 0xA4C4 (Y0 coordinate)

Once the report has been transmitted, nIRQ de-asserts.

Green is target 0's X position.
Orange is target 0's Y position.
Yellow is target 0's Z value.
Grey is the remaining X/Y values.
Pink is the remaining Z values.

Removal of the finger touch

```
Start, CC [ 66 | WR ], 00, 08, 3A, 80, Stop
Start, CD [ 66 | RD ], 1D, 41, 00, 00, 14, 86, 84, A4,
00, 00, 00, 00, 00, 00, 00, 00, 00, 00, 00, 00, 00, 00, 00,
00, 00, 00, 00, 00, 00, 00, 00, 00, 00, 00, 00, 00, 00, 00,
00, 00, 00, 00, 00, 00, 00, 00, 00, 00, 00, 00, 00, 00, 00,
00, 00, 00, 00, 00, 00, 00, 00, 00, 00, 00, 00, 00, 00, 00,
00, 00, 00, 00, 03, 58, 2C, 21 NAK, Stop
```

13. INSPECTION CRITERIA

13.1 APPLICATION

THIS INSPECTION STANDARD IS TO BE APPLIED TO THE LCD MODULE DELIVERED FROM EMERGING DISPLAY TECHNOLOGIES CORP.(E.D.T) TO CUSTOMERS

13.2 INSPECTION CONDITIONS

13.2.1 (1)OBSERVATION DISTANCE : 45 ± 5 cm

(2)VIEWING ANGLE : $\pm 45^\circ$

$\pm 45^\circ$ (FOR SECTION WITHIN VIEWING AREA), REFER TO FIG.A
 90° (FOR SECTION OUTSIDE OF VIEWING AREA), REF TO FIG.B
 PERPENDICULAR TO MODULE SURFACE

VIEWING ANGLE SHOULD BE SMALLER THAN 45°

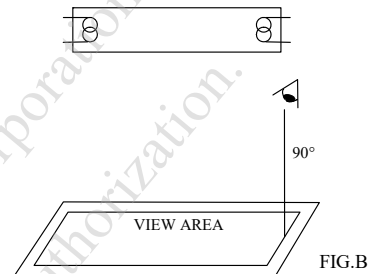
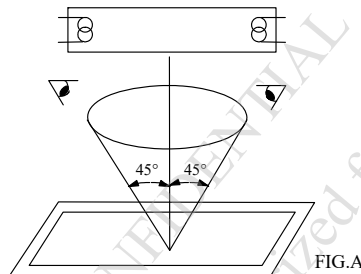

THE INSPECTION CRITERIA IS ACCORDING TO LINE OF SIGHT. INSPECTION SHALL BE MADE WITHIN THE HALF SECTION OF THE VIEWING CONE GENERATED BY LINE SEGMENT OF 45° WITH RESPECT TO THE VERTICAL AXIS FROM CENTER VERTEX OF LCD, THE FLUORESCENT LAMP AND THE CONE AXIS MUST BE PERPENDICULAR TO THE LCD SURFACE.

IF THE DEFECTS ARE OUTSIDE OF VIEWING AREA, IT SHALL BE INSPECTED BY 90° WITH RESPECT TO THE VERTICAL AXIS FROM EDGE OF VIEWING AREA.

13.2.2 ENVIRONMENT CONDITIONS :

AMBIENT TEMPERATURE		$20 \pm 5^\circ\text{C}$
AMBIENT HUMIDITY		$55 \pm 20\% \text{RH}$
AMBIENT ILLUMINATION	COSMETIC INSPECTION	600~800 lux
	FUNCTIONAL INSPECTION	300~500 lux
INSPECTION TIME		15 secs

13.2.3 INSPECTION LOT

QUANTITY PER DELIVERY LOT FOR EACH MODEL

13.2.4 INSPECTION METHOD

A SAMPLING INSPECTION SHALL BE MADE ACCORDING TO THE FOLLOWING PROVISIONS TO JUDGE THE ACCEPTABILITY

(a)APPLICABLE STANDARD :





ANSI/ ASQ Z1.4 NORMAL INSPECTION LEVEL II

(b)AQL : MAJOR DEFECT : AQL 0.65

MINOR DEFECT : AQL 1.5

13.3 DEFECTS CLASSIFICATION

TYPE OF DEFECT	INSPECTION ITEM	DEFECT FEATURE	AQL
MAJOR DEFECT	1.DISPLAY ON	<ul style="list-style-type: none"> • DEFECT TO MISS SPECIFIED DISPLAY FUNCTION, FOR ALL AND SPECIFIED DOTS EX: DISCONNECTION, SHORT CIRCUIT ETC 	0.65
	2.CTP FUNCTION	<ul style="list-style-type: none"> • NO FUNCTION • BROKEN LINE • FALSE TOUCH 	
	3.BACKLIGHT	<ul style="list-style-type: none"> • NO LIGHT • FLICKERING AND OTHER ABNORMAL ILLUMINATION 	
	4.DIMENSIONS	<ul style="list-style-type: none"> • SUBJECT TO INDIVIDUAL ACCEPTANCE SPECIFICATIONS 	
MINOR DEFECT	1.DISPLAY ZONE (VIEWING AREA)	<ul style="list-style-type: none"> • BLACK/WHITE SPOT / CIRCULAR TYPE • BUBBLES ON POLARIZER • NEWTON RING • BLACK/WHITE LINE / LINEAR TYPE • SCRATCH • CONTAMINATION • UNEVEN COLOR SPREAD 	1.0
	2.BEZEL ZONE	<ul style="list-style-type: none"> • STAINS • SCRATCHES • FOREIGN MATTER 	
	3.SOLDERING	<ul style="list-style-type: none"> • INSUFFICIENT SOLDER • SOLDERED IN INCORRECT POSITION • CONVEX SOLDERING SPOT • SOLDER BALLS • SOLDER SCRAPS 	
	4.DISPLAY ON (ALL ON)	<ul style="list-style-type: none"> • LIGHT LINE 	

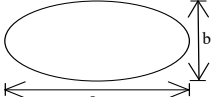
NO.	ITEM	CRITERIA																																								
1	DISPLAY ON INSPECTION	1.INCORRECT PATTERN 2.MISSING SEGMENT 3.DIM SEGMENT 4.OPERATING VOLTAGE BEYOND SPEC																																								
2	OVERALL DIMENSIONS	OVERALL DIMENSION BEYOND SPEC																																								
3	DOT DEFECT	<p>1.INSPECTION PATTERN: FULL WHITE, FULL BLACK, RED, GREEN AND BLUE SCREENS.</p> <p>2.</p> <table border="1"> <thead> <tr> <th colspan="2">ITEM</th> <th>STANDARD</th> </tr> </thead> <tbody> <tr> <td colspan="2"></td> <td>Z</td> </tr> <tr> <td rowspan="3">BRIGHT DOT</td> <td>RANDOM</td> <td>N≤2</td> </tr> <tr> <td>2 DOTS ADJACENT (PAIR)</td> <td>N=0</td> </tr> <tr> <td>3 DOTS ADJACENT OR MORE</td> <td>N=0</td> </tr> <tr> <td rowspan="3">DARK DOT</td> <td>RANDOM</td> <td>N≤4</td> </tr> <tr> <td>2 DOTS ADJACENT (PAIR)</td> <td>N=0</td> </tr> <tr> <td>3 DOTS ADJACENT OR MORE</td> <td>N=0</td> </tr> <tr> <td rowspan="2">DISTANCE</td> <td>MINIMUM DISTANCE BETWEEN BRIGHT DOTS</td> <td>—</td> </tr> <tr> <td>MINIMUM DISTANCE BETWEEN DARK DOTS</td> <td>L≥5mm</td> </tr> <tr> <td colspan="2">TOTAL BRIGHT AND DARK DOT</td> <td>N≤6</td> </tr> <tr> <td colspan="2">SMALL BRIGHT DOT</td> <td>N≤3 DISTANCE≤5mm N≤5 DISTANCE≥5mm</td> </tr> <tr> <td colspan="2">MICRO BRIGHT DOT(ND 8% NOT OBSERVED)</td> <td>N=0</td> </tr> <tr> <td colspan="2">DISPLAY FAILURE (V-LINE/H-LINE/CROSS LINE ETC.)</td> <td>NOT ALLOWABLE</td> </tr> <tr> <td>MURA</td> <td>JUDGE BY LIMIT SAMPLE OR NOT VISIBLE THROUGH ND FILTER</td> <td>ND 5%</td> </tr> </tbody> </table> <p>NOTE :</p> <ol style="list-style-type: none"> THE DEFINITION OF DOT: DOTS THAT CAN BE SEEN THROUGH A 8% ND FILTER,AND THE SIZE OF A DEFECTIVE DOT OVER IS 1/2 OF WHOLE DOT. BRIGHT DOT: DOTS THAT CAN BE SEEN THROUGH A 8% ND FILTER, AND THE SIZE OF A DEFECTIVE DOT IS THE WHOLE DOT. DARK DOT: DOTS APPEAR DARK AND UNCHANGED IN SIZE IN WHICH LCD PANEL IS DISPLAYING UNDER PURE RED, GREEN, BLUE PICTURE. MICRO BRIGHT DOT: DOTS THAT CANNOT BE SEEN THROUGH A 8% ND FILTER, AND THE SIZE OF A DEFECTIVE DOT IS THE WHOLE DOT. SMALL BRIGHT DOT: THE SIZE OF A DEFECTIVE DOT IS LESS THAN 1/2 OF WHOLE DOT. <p>6.2 DOT ADJACENT=1PAIR=2DOTS.</p> <div style="display: flex; justify-content: space-around; align-items: center;"> <div style="text-align: center;">  2 dot adjacent </div> <div style="text-align: center;">  2 dot adjacent </div> <div style="text-align: center;">  2 dot adjacent(vertical) </div> <div style="text-align: center;">  2 dot adjacent(slant) </div> </div>	ITEM		STANDARD			Z	BRIGHT DOT	RANDOM	N≤2	2 DOTS ADJACENT (PAIR)	N=0	3 DOTS ADJACENT OR MORE	N=0	DARK DOT	RANDOM	N≤4	2 DOTS ADJACENT (PAIR)	N=0	3 DOTS ADJACENT OR MORE	N=0	DISTANCE	MINIMUM DISTANCE BETWEEN BRIGHT DOTS	—	MINIMUM DISTANCE BETWEEN DARK DOTS	L≥5mm	TOTAL BRIGHT AND DARK DOT		N≤6	SMALL BRIGHT DOT		N≤3 DISTANCE≤5mm N≤5 DISTANCE≥5mm	MICRO BRIGHT DOT(ND 8% NOT OBSERVED)		N=0	DISPLAY FAILURE (V-LINE/H-LINE/CROSS LINE ETC.)		NOT ALLOWABLE	MURA	JUDGE BY LIMIT SAMPLE OR NOT VISIBLE THROUGH ND FILTER	ND 5%
ITEM		STANDARD																																								
		Z																																								
BRIGHT DOT	RANDOM	N≤2																																								
	2 DOTS ADJACENT (PAIR)	N=0																																								
	3 DOTS ADJACENT OR MORE	N=0																																								
DARK DOT	RANDOM	N≤4																																								
	2 DOTS ADJACENT (PAIR)	N=0																																								
	3 DOTS ADJACENT OR MORE	N=0																																								
DISTANCE	MINIMUM DISTANCE BETWEEN BRIGHT DOTS	—																																								
	MINIMUM DISTANCE BETWEEN DARK DOTS	L≥5mm																																								
TOTAL BRIGHT AND DARK DOT		N≤6																																								
SMALL BRIGHT DOT		N≤3 DISTANCE≤5mm N≤5 DISTANCE≥5mm																																								
MICRO BRIGHT DOT(ND 8% NOT OBSERVED)		N=0																																								
DISPLAY FAILURE (V-LINE/H-LINE/CROSS LINE ETC.)		NOT ALLOWABLE																																								
MURA	JUDGE BY LIMIT SAMPLE OR NOT VISIBLE THROUGH ND FILTER	ND 5%																																								
4	BUBBLES ON POLARIZER /SURFACE STAINS /DIRT/CF FAIL/SPOT	<table border="1"> <thead> <tr> <th></th> <th>AVERAGE DIAMETER (mm) : D</th> <th>NUMBER OF PIECES PERMITTED</th> </tr> </thead> <tbody> <tr> <td rowspan="3">BUBBLE ON THE POLARIZER</td> <td>D ≤ 0.25</td> <td>IGNORE</td> </tr> <tr> <td>0.25 < D ≤ 0.5</td> <td>4</td> </tr> <tr> <td>D > 0.5</td> <td>0</td> </tr> <tr> <td rowspan="3">POLARIZER SCRATCH</td> <td>W < 0.05</td> <td>IGNORE</td> </tr> <tr> <td>0.05 < W ≤ 0.1, 2 < L ≤ 5</td> <td>4</td> </tr> <tr> <td>W > 0.1</td> <td>0</td> </tr> <tr> <td rowspan="3">CF FAIL / SPOT</td> <td>D < 0.25</td> <td>IGNORE</td> </tr> <tr> <td>0.25 < D ≤ 0.5</td> <td>4</td> </tr> <tr> <td>D > 0.5</td> <td>0</td> </tr> </tbody> </table> <p>NOTE : (1)POLARIZER BUBBLE IS DEFINED AS THE BUBBLE APPEARS ON ACTIVE DISPLAY AREA. THE DEFECT OF POLARIZER BUBBLE SHALL BE IGNORED IF THE POLARIZER BUBBLE APPEARS ON THE OUTSIDE OF ACTIVE DISPLAY AREA.</p> <p>(2)THE EXTRANEIOUS SUBSTANCE IS DEFINED AS IT CAN BE OBSERVED WHEN THE MODULE IS POWER ON.</p> <p>(3)THE DEFINITION OF AVERAGE DIAMETER, D IS DEFINED AS FOLLOWING.</p> <p>AVERAGE DIAMETER (D)=(a+b)/2</p> <div style="text-align: center;">  </div>		AVERAGE DIAMETER (mm) : D	NUMBER OF PIECES PERMITTED	BUBBLE ON THE POLARIZER	D ≤ 0.25	IGNORE	0.25 < D ≤ 0.5	4	D > 0.5	0	POLARIZER SCRATCH	W < 0.05	IGNORE	0.05 < W ≤ 0.1, 2 < L ≤ 5	4	W > 0.1	0	CF FAIL / SPOT	D < 0.25	IGNORE	0.25 < D ≤ 0.5	4	D > 0.5	0																
	AVERAGE DIAMETER (mm) : D	NUMBER OF PIECES PERMITTED																																								
BUBBLE ON THE POLARIZER	D ≤ 0.25	IGNORE																																								
	0.25 < D ≤ 0.5	4																																								
	D > 0.5	0																																								
POLARIZER SCRATCH	W < 0.05	IGNORE																																								
	0.05 < W ≤ 0.1, 2 < L ≤ 5	4																																								
	W > 0.1	0																																								
CF FAIL / SPOT	D < 0.25	IGNORE																																								
	0.25 < D ≤ 0.5	4																																								
	D > 0.5	0																																								

NO.	ITEM	CRITERIA												
5	BLACK/WHITE SPOT CIRCULAR TYPE	THE FOLLOWING BLACK/WHITE SPOT ARE WITHIN THE VIEWING AREA. AVERAGE DIAMETER : D (mm) <table border="1"> <thead> <tr> <th>SIZE D</th> <th>PERMISSIBLE NO.</th> </tr> </thead> <tbody> <tr> <td>D≤0.2mm</td> <td>IGNORE</td> </tr> <tr> <td>0.2mm<D≤0.3mm</td> <td>8</td> </tr> <tr> <td>0.3mm<D≤0.5mm</td> <td>8</td> </tr> <tr> <td>D>0.5 mm</td> <td>0</td> </tr> </tbody> </table> NOTE (1) : THE DISTANCE BETWEEN DEFECTS SHOULD BE MORE THAN 10mm APART.		SIZE D	PERMISSIBLE NO.	D≤0.2mm	IGNORE	0.2mm<D≤0.3mm	8	0.3mm<D≤0.5mm	8	D>0.5 mm	0	
SIZE D	PERMISSIBLE NO.													
D≤0.2mm	IGNORE													
0.2mm<D≤0.3mm	8													
0.3mm<D≤0.5mm	8													
D>0.5 mm	0													
6	SCRATCH	THE FOLLOWING BLACK LINE, WHITE LINE IS WITHIN THE VIEWING AREA. WIDTH : W (mm) , LENGTH : L (mm) <table border="1"> <thead> <tr> <th>SIZE W & L</th> <th>PERMISSIBLE NO.</th> </tr> </thead> <tbody> <tr> <td>W≤0.07mm</td> <td>IGNORE</td> </tr> <tr> <td>0.07mm<W≤0.1mm, L≤10mm</td> <td>5</td> </tr> <tr> <td>0.1mm<W≤0.15mm, L≤15mm</td> <td>3</td> </tr> <tr> <td>W>0.15mm</td> <td>0</td> </tr> </tbody> </table> NOTE (1) : THE DISTANCE BETWEEN DEFECTS SHOULD BE MORE THAN 10mm APART.		SIZE W & L	PERMISSIBLE NO.	W≤0.07mm	IGNORE	0.07mm<W≤0.1mm, L≤10mm	5	0.1mm<W≤0.15mm, L≤15mm	3	W>0.15mm	0	
SIZE W & L	PERMISSIBLE NO.													
W≤0.07mm	IGNORE													
0.07mm<W≤0.1mm, L≤10mm	5													
0.1mm<W≤0.15mm, L≤15mm	3													
W>0.15mm	0													
7	BLACK / WHITE LINE LINEAR TYPE / FOREIGN FIBER	THE FOLLOWING BLACK LINE, WHITE LINE IS WITHIN THE VIEWING AREA. WIDTH : W (mm) , LENGTH : L (mm) <table border="1"> <thead> <tr> <th>SIZE W & L</th> <th>PERMISSIBLE NO.</th> </tr> </thead> <tbody> <tr> <td>W≤0.07mm</td> <td>IGNORE</td> </tr> <tr> <td>0.07mm<W≤0.1mm, L≤10mm</td> <td>5</td> </tr> <tr> <td>0.1mm<W≤0.15mm, L≤15mm</td> <td>3</td> </tr> <tr> <td>W>0.15mm</td> <td>0</td> </tr> </tbody> </table> NOTE (1) : THE DISTANCE BETWEEN DEFECTS SHOULD BE MORE THAN 10mm APART.		SIZE W & L	PERMISSIBLE NO.	W≤0.07mm	IGNORE	0.07mm<W≤0.1mm, L≤10mm	5	0.1mm<W≤0.15mm, L≤15mm	3	W>0.15mm	0	
SIZE W & L	PERMISSIBLE NO.													
W≤0.07mm	IGNORE													
0.07mm<W≤0.1mm, L≤10mm	5													
0.1mm<W≤0.15mm, L≤15mm	3													
W>0.15mm	0													
8	BUBBLE / DENT FOR OPTICAL BONDING	BUBBLES WITHIN VIEWING AREA. AVERAGE DIAMETER : D (mm) <table border="1"> <thead> <tr> <th>SIZE D</th> <th>PERMISSIBLE NO.</th> </tr> </thead> <tbody> <tr> <td>D≤0.2mm</td> <td>IGNORE</td> </tr> <tr> <td>0.2mm<D≤0.3mm</td> <td>3</td> </tr> <tr> <td>0.3mm<D≤0.5mm</td> <td>1</td> </tr> <tr> <td>D>0.5mm</td> <td>0</td> </tr> </tbody> </table> NOTE (1) : THE DISTANCE BETWEEN DEFECTS SHOULD BE MORE THAN 10mm APART.		SIZE D	PERMISSIBLE NO.	D≤0.2mm	IGNORE	0.2mm<D≤0.3mm	3	0.3mm<D≤0.5mm	1	D>0.5mm	0	
SIZE D	PERMISSIBLE NO.													
D≤0.2mm	IGNORE													
0.2mm<D≤0.3mm	3													
0.3mm<D≤0.5mm	1													
D>0.5mm	0													
9	CHIPPING	<table border="1"> <tbody> <tr> <td>CORNER</td> <td>$X \leq 3\text{mm} \cdot Y \leq 3\text{mm} \cdot Z \leq t$ (t : THICKNESS)</td> </tr> <tr> <td>EDGE</td> <td>$X \leq 6\text{mm} \cdot Y \leq 1\text{mm} \cdot Z < t$ (t : THICKNESS)</td> </tr> </tbody> </table>	CORNER	$X \leq 3\text{mm} \cdot Y \leq 3\text{mm} \cdot Z \leq t$ (t : THICKNESS)	EDGE	$X \leq 6\text{mm} \cdot Y \leq 1\text{mm} \cdot Z < t$ (t : THICKNESS)								
CORNER	$X \leq 3\text{mm} \cdot Y \leq 3\text{mm} \cdot Z \leq t$ (t : THICKNESS)													
EDGE	$X \leq 6\text{mm} \cdot Y \leq 1\text{mm} \cdot Z < t$ (t : THICKNESS)													
10	CRACKED GLASS	NOT ACCEPTABLE												
11	LINE DEFECT ON DISPLAY	OBVIOUS VERTICAL OR HORIZONTAL LINE DEFECT IS NOT ALLOWED.												
12	MURA ON DISPLAY	IT'S ACCEPTABLE, IF MURA IS SLIGHT VISIBLE THROUGH 5% ND FILTER.												
13	UNEVEN COLOR SPREAD, COLORATION	TO BE DETERMINED BASED UPON THE LIMITED SAMPLE.												
14	BEZEL APPEARANCE	1. BEZEL MAY NOT HAVE RUST, BE DEFORMED OR HAVE FINGER PRINTS STAINS OF OTHER CONTAMINATION. 2. BEZEL MUST COMPLY WITH JOB SPECIFICATIONS.												

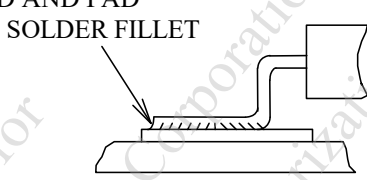
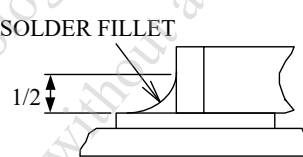
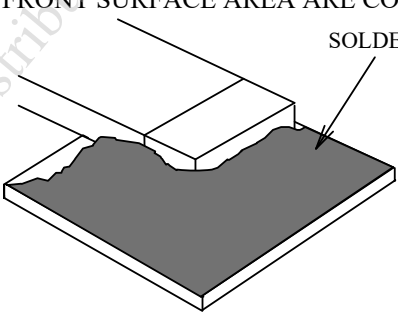
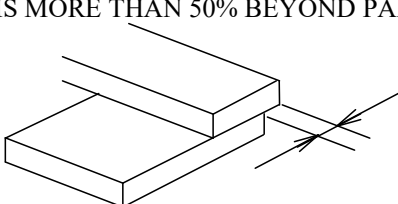
NO.	ITEM	CRITERIA
15	PCB	<ol style="list-style-type: none"> 1. THERE MAY NOT BE MORE THAN 2mm OF SEALANT OUTSIDE THE SEAL AREA ON THE PCB, AND THERE SHOULD BE NO MORE THAN THREE PLACES. 2. NO OXIDATION OR CONTAMINATION ON PCB TERMINALS. 3. PARTS ON PCB MUST BE THE SAME AS ON THE PRODUCTION CHARACTERISTIC CHART. THERE SHOULD BE NO WRONG PARTS, MISSING PARTS OR EXCESS PARTS. 4. THE JUMPER ON THE PCB SHOULD CONFORM TO THE PRODUCT CHARACTERISTIC CHART. 5. IF SOLDER GETS ON BEZEL TAB PADS, LED PAD, ZEBRA PAD OR SCREW HOLD PAD; MAKE SURE IT IS SMOOTHED DOWN.
16	SOLDERING	<ol style="list-style-type: none"> 1. NO SOLDERING FOUND ON THE SPECIFIED PLACE 2. INSUFFICIENT SOLDER <ol style="list-style-type: none"> (a) LSI, IC A POOR WETTING OF SOLDER IS BETWEEN LOWER BEND OR "HEEL" OF LEAD AND PAD  (b) CHIP COMPONENT <ul style="list-style-type: none"> · SOLDER IS LESS THAN 50% OF SIDES AND FRONT FACE WETTING  · SOLDER WETS 3 SIDES OF TERMINAL, BUT LESS THAN 25% OF SIDES AND FRONT SURFACE AREA ARE COVERED  3. PARTS ALIGNMENT <ol style="list-style-type: none"> (a) LSI, IC LEAD WIDTH IS MORE THAN 50% BEYOND PAD OUTLINE 

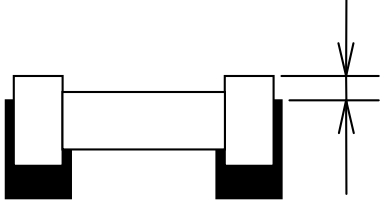
NO.	ITEM	CRITERIA
16	SOLDERING	<p>(b)CHIP COMPONENT COMPONENT IS OFF CENTER, AND MORE THAN 50% OF THE LEADS IS OFF THE PAD OUTLINE</p>  <p>4. NO UNMELTED SOLDER PASTE MAY BE PRESENT ON THE PCB. 5. NO COLD SOLDER JOINTS, MISSING SOLDER CONNECTIONS, OXIDATION OR ICICLE. 6. NO RESIDUE OR SOLDER BALLS ON PCB. 7. NO SHORT CIRCUITS IN COMPONENTS ON PCB.</p>
17	BACKLIGHT	<p>1. NO LIGHT 2. FLICKERING AND OTHER ABNORMAL ILLUMINATION 3. SPOTS OR SCRATCHES THAT APPEAR WHEN LIT MUST BE JUDGED USING LCD SPOT, LINES AND CONTAMINATION STANDARDS. 4. BACKLIGHT DOESN'T LIGHT OR COLOR IS WRONG.</p>
18	GENERAL APPEARANCE	<p>1. NO OXIDATION, CONTAMINATION, CURVES OR, BENDS ON INTERFACE PIN (OLB) OF TCP. 2. NO CRACKS ON INTERFACE PIN (OLB) OF TCP. 3. NO CONTAMINATION, SOLDER RESIDUE OR SOLDER BALLS ON PRODUCT. 4. THE IC ON THE TCP MAY NOT BE DAMAGED, CIRCUITS. 5. THE UPPERMOST EDGE OF THE PROTECTIVE STRIP ON THE INTERFACE PIN MUST BE PRESENT OR LOOK AS IF IT CAUSE THE INTERFACE PIN TO SEVER. 6. THE RESIDUAL ROSIN OR TIN OIL OF SOLDERING (COMPONENT OR CHIP COMPONENT) IS NOT BURNED INTO BROWN OR BLACK COLOR. 7. SEALANT ON TOP OF THE ITO CIRCUIT HAS NOT HARDENED. 8. PIN TYPE MUST MATCH TYPE IN SPECIFICATION SHEET. 9. LCD PIN LOOSE OR MISSING PINS. 10. PRODUCT PACKAGING MUST BE THE SAME AS SPECIFIED ON PACKAGING SPECIFICATION SHEET. 11. PRODUCT DIMENSION AND STRUCTURE MUST CONFORM TO PRODUCT SPECIFICATION SHEET. 12. THE APPEARANCE OF HEAT SEAL SHOULD NOT ADMIT ANY DIRT AND BREAK.</p>

NOTE (1) : FOR ANY SPOTS OR LINES, WHICH ARE NOT OBSERVED UNDER APPROPRIATE PANEL
OPERATING CONDITION ARE DEEMED ACCEPTABLE.

NOTE (2) : THE FOREIGN MATERIALS THAT CAN BE BLOWN OUT BY AIR AND REMOVED BY WET
CLEANING ARE NOT REGARDED AS DEFECTS.

14. RELIABILITY TEST

14.1 STANDARD SPECIFICATIONS FOR RELIABILITY OF LCD MODULE

NO.	ITEM	DESCRIPTION
1	HIGH TEMPERATURE TEST (OPERATION)	THE SAMPLE SHOULD BE ALLOWED TO STAND AT +85°C FOR 240 HRS
2	LOW TEMPERATURE TEST (OPERATION)	THE SAMPLE SHOULD BE ALLOWED TO STAND AT -30°C FOR 240 HRS
3	HIGH TEMPERATURE TEST (STORAGE)	THE SAMPLE SHOULD BE ALLOWED TO STAND AT +85°C FOR 240 HRS
4	LOW TEMP TEST (STORAGE)	THE SAMPLE SHOULD BE ALLOWED TO STAND AT -30°C FOR 240 HRS
5	HIGH TEMPERATURE /HUMIDITY TEST (STORAGE)	THE SAMPLE SHOULD BE ALLOWED TO STAND AT 40°C , 90% RH 240 HRS
6	THERMAL SHOCK (NOT OPERATED)	<p>THE SAMPLE SHOULD BE ALLOWED TO STAND THE FOLLOWING 10 CYCLES OF OPERATION:</p>
7	ESD (ELECTROSTATIC DISCHARGE) (NOT OPERATED)	AIR DISCHARGE ± 12KV CONTACT DISCHARGE ± 8KV (ACCORDING TO IEC-61000-4-2)

NOTE (1) : THE TEST SAMPLES HAVE RECOVERY TIME FOR 2 HOURS AT ROOM TEMPERATURE BEFORE THE FUNCTION CHECK. IN THE STANDARD CONDITIONS, THERE IS NO DISPLAY FUNCTION NG ISSUE OCCURRED.

NOTE (2) : WHEN THE LCD MODULE IS OPERATED AT AMBIENT TEMPERATURE 80°C, THE PWM DUTY CYCLE OF THE LED BACKLIGHT SHOULD BE ADJUSTED TO BE LESS THAN 30%. IF THE MODULE IS OPERATED AT A HIGHER DUTY CYCLE THAN 40%, THEN THERE IS A POSSIBILITY OF DISTORTION AND IRREGULARITY OF THE PICTURE DUE TO LIQUID CRYSTAL BEHAVIOR.

NOTE (3) : TESTING CONDITIONS AND INSPECTION CRITERIA

NO.	ITEM	TEST MODEL	INSPECTION CRITERIA
1	CURRENT CONSUMPTION	REFER TO SPECIFICATION	THE CURRENT CONSUMPTION SHOULD CONFORM TO THE PRODUCT SPECIFICATION.
2	CONTRAST	REFER TO SPECIFICATION	AFTER THE TESTS HAVE BEEN EXECUTED, THE CONTRAST MUST BE LARGER THAN HALF OF ITS INITIAL VALUE PRIOR TO THE TESTS.
3	APPEARANCE	VISUAL INSPECTION	DEFECT FREE

15. CAUTION

15.1 OPERATION

- 15.1.1 DO NOT CONNECT OR DISCONNECT MODULES TO OR FROM THE MAIN SYSTEM WHILE POWER IS BEING SUPPLIED .
- 15.1.2 USE THE MODULE WITHIN SPECIFIED TEMPERATURE ; LOWER TEMPERATURE CAUSES THE RETARDATION OF BLINKING SPEED OF THE DISPLAY ; HIGHER TEMPERATURE MAKES OVERALL DISPLAY DISCOLOR . WHEN THE TEMPERATURE RETURNS TO NORMALITY, THE DISPLAY WILL OPERATE NORMALLY.
- 15.1.3 ADJUST THE LC DRIVING VOLTAGE TO OBTAIN THE OPTIMUM CONTRAST .
- 15.1.4 POWER ON SEQUENCE INPUT SIGNALS SHOULD NOT BE SUPPLIED TO LCD MODULE BEFORE POWER SUPPLY VOLTAGE IS APPLIED AND REACHES THE SPECIFIED VALUE.
IF ABOVE SEQUENCE IS NOT FOLLOWED , CMOS LSIS OF LCD MODULES MAY BE DAMAGED DUE TO LATCH - UP PROBLEM.
- 15.1.5 NOT ALLOWED TO INFLICT ANY EXTERNAL STRESS AND TO CAUSE ANY MECHANICAL INTERFERENCE ON THE BENDING AREA OF FPC DURING THE TAIL BENDING BACKWARDS!
DO NOT STRESS FPC AND IC ON THE MODULE!

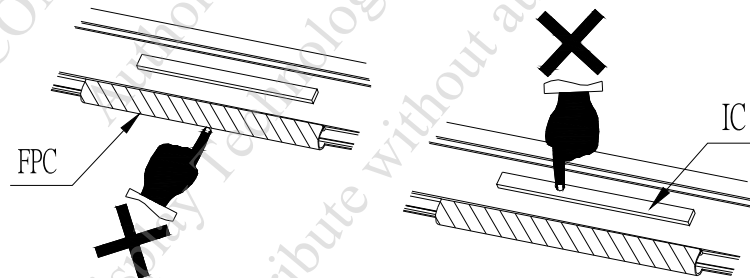

15.2 NOTICE

- 15.2.1 USE A GROUNDED SOLDERING IRON WHEN SOLDERING CONNECTOR I/O TERMINALS . FOR SOLDERING OR REPAIRING, TAKE PRECAUTION AGAINST THE TEMPERATURE OF THE SOLDERING IRON AND THE SOLDERING TIME TO PREVENT PEELING OFF THE THROUGH-HOLE-PAD .
- 15.2.2 DO NOT DISASSEMBLE . EDT SHALL NOT BE HELD RESPONSIBLE IF THE MODULE IS DISASSEMBLED AND UPON THE REASSEMBLY THE MODULE FAILED.
- 15.2.3 DO NOT CHARGE STATIC ELECTRICITY, AS THE CIRCUIT OF THIS MODULE CONTAINS CMOS LSIS. A WORKMAN'S BODY SHOULD ALWAYS BE STATIC-PROTECTED BY USE OF AN ESD STRAP. WORKING CLOTHES FOR SUCH PERSONNEL SHOULD BE OF STATIC-PROTECTED MATERIAL.
- 15.2.4 ALWAYS GROUND THE ELECTRICALLY-POWERED DRIVER BEFORE USING IT TO INSTALL THE LCD MODULE. WHILE CLEANING THE WORK STATION BY VACUUM CLEANER, DO NOT BRING THE SUCKING MOUTH NEAR THE MODULE ; STATIC ELECTRICITY OF THE ELECTRICALLY-POWERED DRIVER OR THE VACUUM CLEANER MAY DESTROY THE MODULE.
- 15.2.5 DON'T GIVE EXTERNAL SHOCK.
- 15.2.6 DON'T APPLY EXCESSIVE FORCE ON THE SURFACE.
- 15.2.7 LIQUID IN LCD IS HAZARDOUS SUBSTANCE. MUST NOT LICK AND SWALLOW.
WHEN THE LIQUID IS ATTACH TO YOUR, SKIN, CLOTH ETC. WASH IT OUT THOROUGHLY AND IMMEDIATELY.
- 15.2.8 DON'T OPERATE IT ABOVE THE ABSOLUTE MAXIMUM RATING.
- 15.2.9 STORAGE IN A CLEAN ENVIRONMENT, FREE FROM DUST, ACTIVE GAS, AND SOLVENT.
- 15.2.10 STORE WITHOUT ANY PHYSICAL LOAD.
- 15.2.11 REWIRING: NO MORE THAN 3 TIMES.