

EXAMINED BY :	EMERGING DISPLAY TECHNOLOGIES CORPORATION	FILE NO . CAS-P00803
Sam Chou		ISSUE : APR.17, 2019
APPROVED BY:		TOTAL PAGE : 33
<i>Chris Wu</i>		VERSION : P

CUSTOMER ACCEPTANCE SPECIFICATIONS

MODEL NO. :
ETM043013EDHA
 (RoHS)
 FOR MESSRS :

CUSTOMER'S APPROVAL

DATE :

BY :

EMERGING DISPLAY
TECHNOLOGIES CORPORATION

MODEL NO.	VERSION	PAGE
ETM043013EDHA	P	0-1

RECORDS OF REVISION	DOC . FIRST ISSUE	APR.17, 2019
---------------------	-------------------	--------------

DATE	REVISED PAGE NO.	SUMMARY
<p><i>CONFIDENTIAL</i></p> <p><i>Authorized for</i></p> <p><i>Emerging Display Technologies Corporation Only.</i></p> <p><i>Do not distribute without authorization.</i></p>		

TABLE OF CONTENTS

NO.	ITEM	PAGE
1.	GENERAL SPECIFICATIONS -----	1
2.	MECHANICAL SPECIFICATIONS -----	1, 2
3.	ABSOLUTE MAXIMUM RATINGS -----	3
4.	ELECTRICAL CHARACTERISTICS -----	4
5.	TIMING CHARACTERISTICS -----	5 ~ 12
6.	OPTICAL CHARACTERISTICS -----	13, 14
7.	OUTLINE DIMENSIONS -----	15
8.	BLOCK DIAGRAM -----	16
9.	DETAIL DRAWING OF DOT MATRIX -----	17
10.	INTERFACE SIGNALS -----	18, 19
11.	POWER SUPPLY -----	20
12.	CAPACITIVE TOUCH PANEL SPECIFICATION -----	21 ~ 24
13.	INSPECTION CRITERION -----	25 ~ 30
14.	RELIABILITY TEST -----	31, 32
15.	CAUTION -----	32, 33

CONFIDENTIAL
 Emergine Display Technologies Corporation
 Do not distribute without authorization.

1. GENERAL SPECIFICATIONS

1.1 DATA SHEETS FOR CONTROLLER/DRIVER

PLEASE REFER TO :

SITRONIX SC7283

1.2 DATA SHEET FOR CAPACITIVE TOUCH PANEL CONTROLLER/DRIVER

PLEASE REFER TO :

HYCON HY4614

1.3 MATERIAL SAFETY DESCRIPTION

ASSEMBLIES SHALL COMPLY WITH EUROPEAN ROHS REQUIREMENTS, INCLUDING PROHIBITED MATERIALS/COMPONENTS CONTAINING LEAD, MERCURY, CADMIUM, HEXAVALENT CHROMIUM, POLYBROMINATED BIPHENYLS (PBB) AND POLYBROMINATED DIPHENYL ETHERS (PBDE), BIS(2-ETHYLHEXYL) PHTHALATE (DEHP), BUTYL BENZYL PHTHALATE (BBP), DIBUTYL PHTHALATE (DBP), DIISOBUTYL PHTHALATE (DIBP).

2. MECHANICAL SPECIFICATIONS

2.1 LCD MODULE MECHANICAL SPECIFICATIONS

(1) DIAGONALS	-----	4.3 inch
(2) NUMBER OF DOTS	-----	480W * (RGB) * 272H DOTS
(3) MODULE SIZE	-----	105.5W * 67.2H * 4.21D mm (NOT INCLUDED FPC)
(4) VIEWING AREA	-----	99W * 56H mm
(5) ACTIVE AREA	-----	95.04W * 53.856H mm
(6) DOT SIZE	-----	0.066W * 0.198H mm
(7) PIXEL PITCH	-----	0.198W * 0.198H mm
(8) LCD TYPE	-----	TFT , TRANSMISSIVE, NORMALLY BLACK
(9) COLOR	-----	16.7M
(10) VIEWING DIRECTION	-----	SUPER WIDE VIEW
(11) BACK LIGHT	-----	LED , COLOR : WHITE
(12) INTERFACE MODE	-----	RGB(24 BIT) PARALLEL (SYNC/DE/SYNC-DE MODE)

MODEL NO.	VERSION	PAGE
ETM043013EDHA	P	2

2.2 CAPACITIVE TOUCH PANEL MECHANICAL SPECIFICATIONS

- (1) TOUCH PANEL SIZE ----- 4.3 inch
- (2) OUTER DIMENSION ----- 103.1W * 65.4H * 1.25D mm
(NOT INCLUDED FPC)
- (3) VIEWING AREA ----- 96.9W * 55.5H mm
- (4) ACTIVE AREA ----- 96W * 55H mm
- (5) INPUT TYPE ----- MULTI TOUCH
- (6) NUMBER OF TOUCH SENSOR ----- 20*12 SENSORS
- (7) RESOLUTION ----- 1280 * 768
- (8) INTERFACE MODE ----- I2C

CONFIDENTIAL
Authorized for
Emerging Display Technologies Corporation Only.
Do not distribute without authorization.

3. ABSOLUTE MAXIMUM RATINGS

3.1 LCD MODULE ELECTRICAL ABSOLUTE MAXIMUM RATINGS

PARAMETER	SYMBOL	MIN.	MAX.	UNIT	REMARK
POWER SUPPLY VOLTAGE	VCC-VSS	-0.3	4.0	V	—
LOGIC INPUT VOLTAGE RANGE	VIN	-0.3	VCC+0.3	V	—
LED BACKLIGHT FORWARD CURRENT	IF	—	25	mA	FOR EACH LED

3.2 CAPACITIVE TOUCH PANEL ELECTRICAL ABSOLUTE MAXIMUM RATINGS

ITEM	SYMBOL	MIN.	MAX.	UNIT	REMARK
POWER SUPPLY FOR DRIVER	VDD-GND	-0.2	4.0	V	
INPUT VOLTAGE	VIN	-0.2	4.0	V	

3.3 ENVIRONMENTAL ABSOLUTE MAXIMUM RATINGS

ITEM	OPERATING		STORAGE		REMARK
	MIN.	MAX.	MIN.	MAX.	
AMBIENT TEMPERATURE	-20°C	70°C	-30°C	80°C	NOTE (1) , (2)
HUMIDITY	NOTE (3)		NOTE (3)		WITHOUT CONDENSATION
VIBRATION	—	2.45 m/s ² (0.25 G)	—	11.76 m/s ² (1.2 G)	10~55Hz X, Y, Z, EACH 2HRS
SHOCK	—	29.4 m/s ² (3 G)	—	490 m/s ² (50 G)	6 ms XYZ DIRECTIONS 3 TIMES EACH
CORROSIVE GAS	NOT ACCEPTABLE		NOT ACCEPTABLE		

NOTE (1) : Ta AT -30°C : 48HRS MAX.

80°C : 168HRS MAX.

NOTE (2) : BACKGROUND COLOR CHANGES SLIGHTLY DEPENDING ON AMBIENT TEMPERATURE THIS PHENOMENON IS REVERSIBLE.

NOTE (3) : Ta ≤ 60°C : 90%RH MAX (96HRS MAX).

Ta > 60°C : ABSOLUTE HUMIDITY MUST BE LOWER THAN THE HUMIDITY OF 90%RH AT 60°C (96HRS MAX).

4. ELECTRICAL CHARACTERISTICS

4.1 TFT MODULE ELECTRICAL CHARACTERISTICS

Ta = 25 °C

ITEM	SYMBOL	CONDITION	MIN.	TYP.	MAX.	UNIT	REMARK
POWER SUPPLY VOLTAGE	VCC-VSS	—	3.15	3.3	3.45	V	
POWER SUPPLY CURRENT	ICC	VCC-VSS =3.3V	—	(20)	(35)	mA	NOTE (1)
INPUT HIGH VOLTAGE	V _{IH}	—	0.7*VCC	—	VCC	V	
INPUT LOW VOLTAGE	V _{IL}	—	VSS	—	0.3*VCC	V	
OUTPUT HIGH VOLTAGE	V _{OH}	I _{OH} = -1.0mA	VCC-0.4	—	VCC	V	
OUTPUT LOW VOLTAGE	V _{OL}	I _{OL} = +1.0mA	VSS	—	VSS+0.4	V	
POWER SUPPLY FOR LED BACKLIGHT	VLED-VLSS	I _{LED} =25mA	(13.8)	(15.5)	(16.7)	V	NOTE (2)
LED LIFE TIME	—	I _F =20mA (PER LED)	30K	—	—	HRS	NOTE (3) NOTE (4)

NOTE (1) : THE DISPLAY PATTERN IS ALL "WHITE"

NOTE (2) : INTERNAL CIRCUIT DIAGRAM OF BACKLIGHT

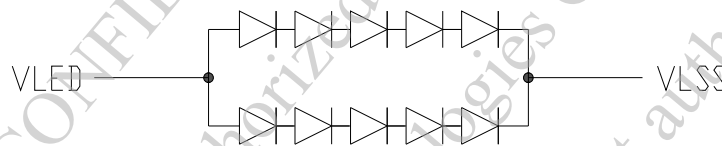

NOTE (3) : CONDITIONS; TA=25 °C, CONTINUOUS LIGHTING

NOTE (4) : DEFINITIONS OF LIFE TIME :

LCM LUMINANCE BECOMES HALF OF THE INITIAL VALUE.

4.2 CAPACITIVE TOUCH PANEL ELECTRICAL CHARACTERISTICS

Ta=25°C

ITEM	SYMBOL	CONDITION	MIN.	TYP.	MAX.	UNIT
POWER SUPPLY FOR DRIVER	VDD-GND	—	2.8	3.3	3.6	V
INPUT HIGH LEVEL VOLTAGE	V _{IH}	—	—	0.7VDD	—	V
INPUT LOW LEVEL VOLTAGE	V _{IL}	—	—	0.3VDD	—	V
OUTPUT HIGH LEVEL VOLTAGE	V _{OH}	I _{OH} =10mA	VDD-0.3	—	—	V
OUTPUT LOW LEVEL VOLTAGE	V _{OL}	I _{OH} =-10mA	—	—	GND+0.3	V
POWER SUPPLY CURRENT CONSUMPTION FOR OPERATION	IDD	VDD-GND=3.3V	—	10	15	mA

5. TIMING CHARACTERISTICS

5.1 FOR LCD MODULE

5.1.1 SYNC MODE

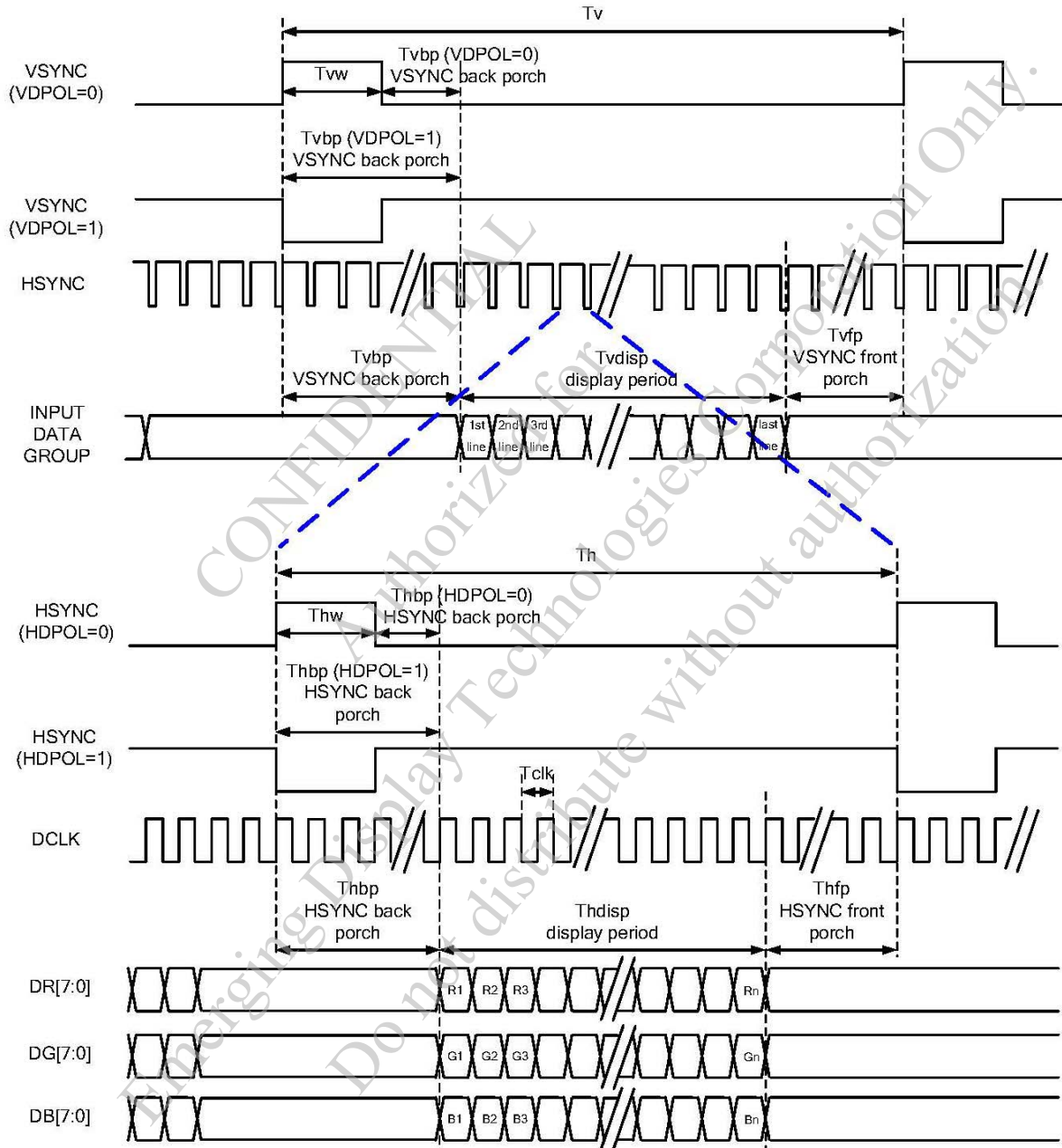

5.1.3 SYNC-DE MODE

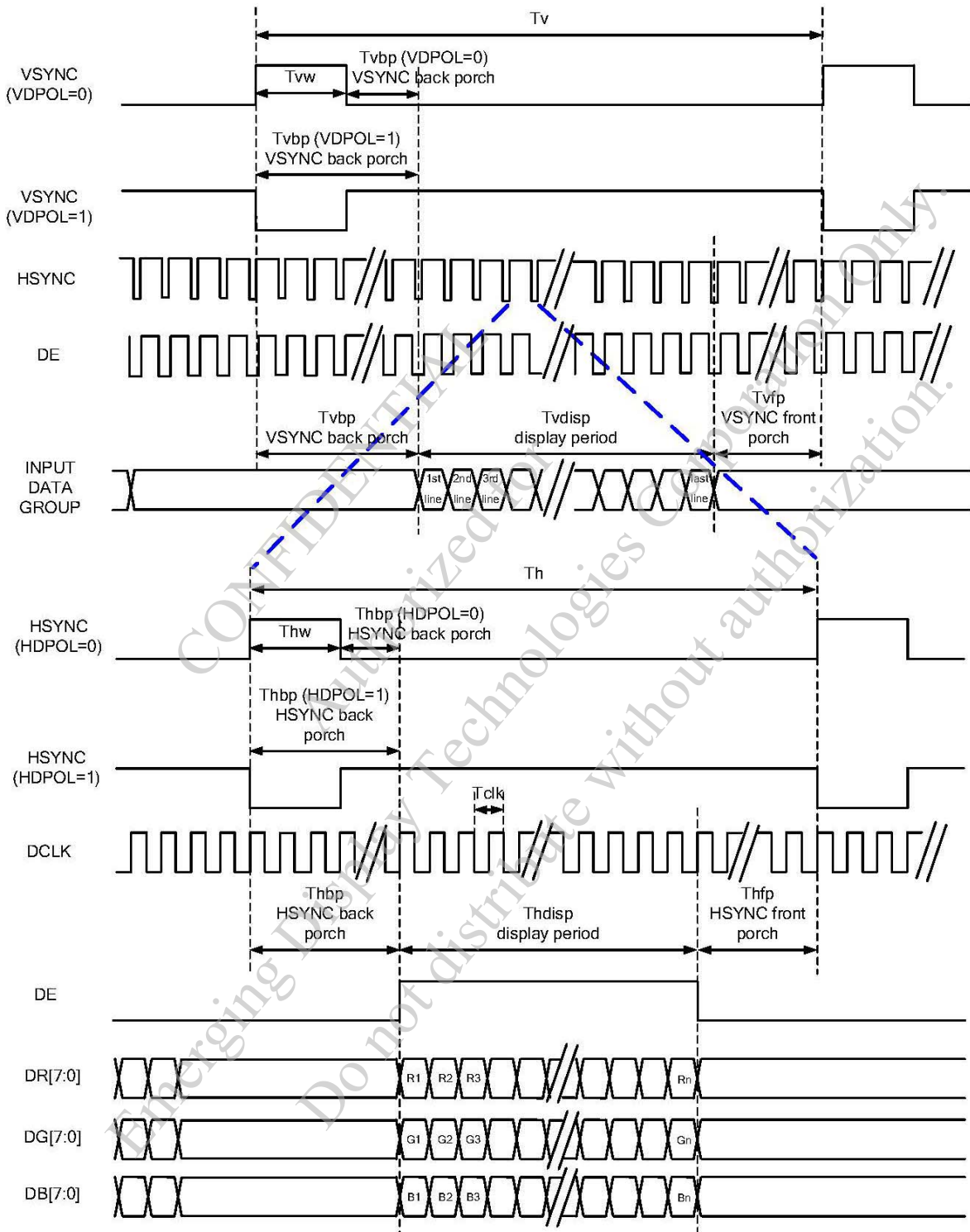

5.1.4 PARALLEL 24 BIT RGB INPUT TIMING TABLE

PARALLEL 24-BIT RGB INPUT TIMING

Ta=25°C

ITEM	SYMBOL	MIN.	TYP.	MAX.	UNIT	REMARK	
DCLK FREQUENCY	Fclk	8	9	12	MHz		
DCLK PERIOD	Tclk	83	111	125	ns		
HSYNC	PERIOD TIME	Th	485	531	598	DCLK	
	DISPLAY PERIOD	Thdisp	—	480	—	DCLK	
	BACK PORCH	Thbp	3	43	43	DCLK	BY H_BLANKING SETTING
	FRONT PORCH	Thfp	2	8	75	DCLK	
	PULSE WIDTH	Thw	2	4	43	DCLK	
VSYNC	PERIOD TIME	Tv	276	292	321	HSYNC	
	DISPLAY PERIOD	Tvdisp		272		HSYNC	
	BACK PORCH	Tvbp	2	12	12	HSYNC	BY V_BLANKING SETTING
	FRONT PORCH	Tvfp	2	8	37	HSYNC	
	PULSE WIDTH	Tvw	2	4	12	HSYNC	

NOTE: IT IS NECESSARY TO KEEP Tvbp =12 AND Thbp =43 IN SYNC MODE. DE MODE IS UNNECESSARY TO KEEP IT.

CONFIDENTIAL
 Authorized for
 Emerging Display Technologies Corporation Only.
 Do not distribute without authorization.

5.1.5 SYSTEM BUS TIMING FOR RGB INTERFACE

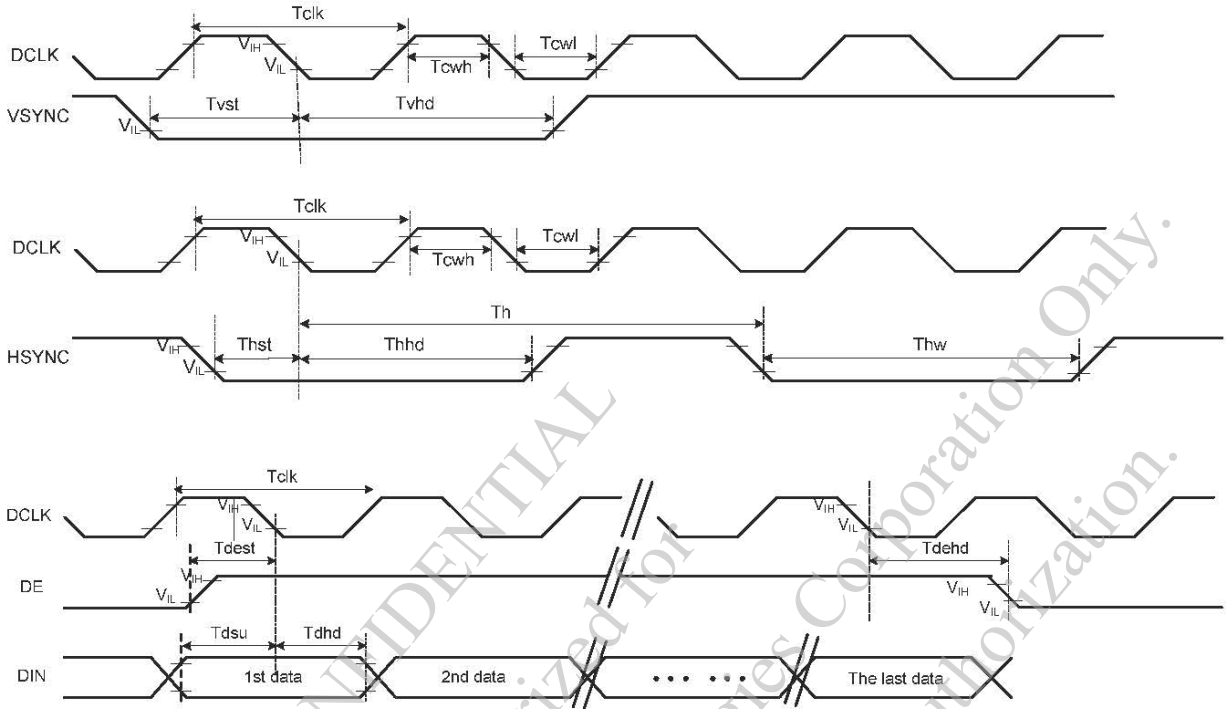

ITEM	SYMBOL	MIN.	TYP.	MAX.	UNIT	CONDITIONS
CLK PULSE DUTY	T_{cw}	40	50	60	%	
HSYNC WIDTH	T_{hw}	2	—	—	DCLK	
HSYNC PERIOD	T_h	55	60	65	us	
VSYNC SETUP TIME	T_{vst}	12	—	—	ns	
VSYNC HOLD TIME	T_{vhd}	12	—	—	ns	
HSYNC SETUP TIME	T_{hst}	12	—	—	ns	
HSYNC HOLD TIME	T_{hhd}	12	—	—	ns	
DATA SETUP TIME	T_{dsu}	12	—	—	ns	
DATA HOLD TIME	T_{dhd}	12	—	—	ns	
DE SETUP TIME	T_{dest}	12	—	—	ns	
DE HOLD TIME	T_{dehd}	12	—	—	ns	

5.1.6 POWER ON SEQUENCE

SYMBOL	DESCRIPTION	MIN. TIME	UNIT
T0	DISPLAY SIGNAL OUTPUT TO BACKLIGHT POWER ON	250	ms

NOTE: RGB INTERFACE DISPLAY SIGNAL: DCLK; VSYNC; HSYNC; DE; DR[7:0]; DG[7:0]; DB[7:0]

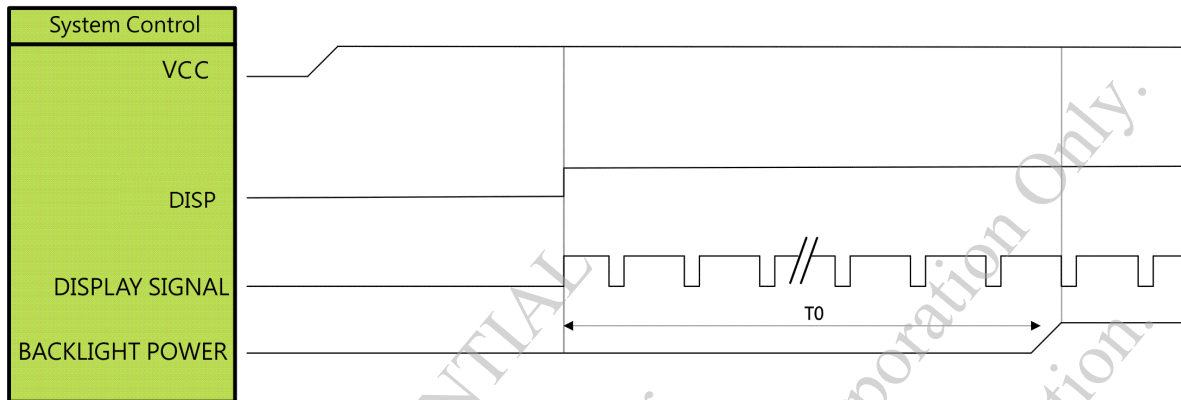

5.1.7 POWER OFF TIMING SEQUENCE

SYMBOL	DESCRIPTION	MIN. TIME	UNIT
T0	BACKLIGHT POWER OFF TO DISP="LOW"	5	ms
T1	DISP="LOW" TO IC INTERNAL VOLTAGE DISCHARGE COMPLETE	100	ms

NOTE: RGB INTERFACE DISPLAY SIGNAL: DCLK; VSYNC; HSYNC; DE; DR[7:0]; DG[7:0]; DB[7:0]

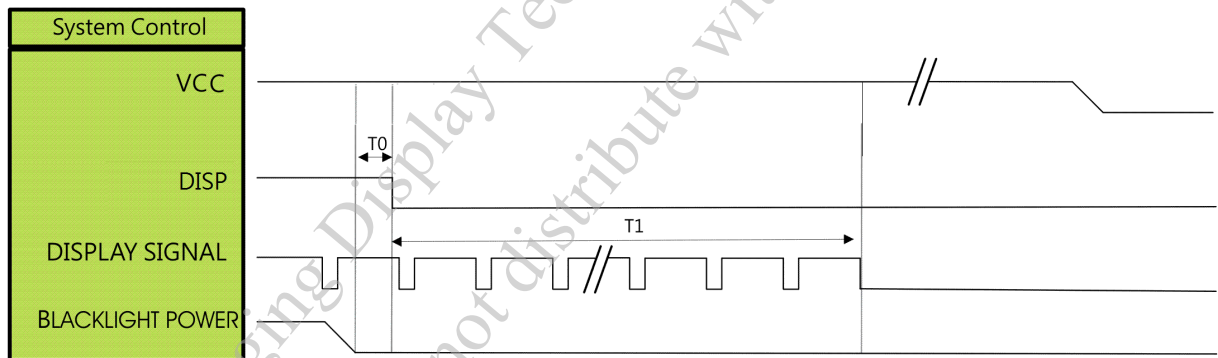

5.2 FOR CTP MODULE

5.2.1 I2C INTERFACE TIMING CHARACTERISTICS

ITEM	MIN.	TYP.	MAX.	UNIT
SCL FREQUENCY	—	—	400	KHz
BUS FREE TIME BETWEEN A STOP AND START CONDITION	1.3	—	—	us
HOLD TIME (REPEATED) START CONDITION	0.6	—	—	us
DATA SETUP TIME	100	—	—	ns
SETUP TIME FOR A REPEATED START CONDITION	0.6	—	—	us
SETUP TIME FOR STOP CONDITION	0.6	—	—	us

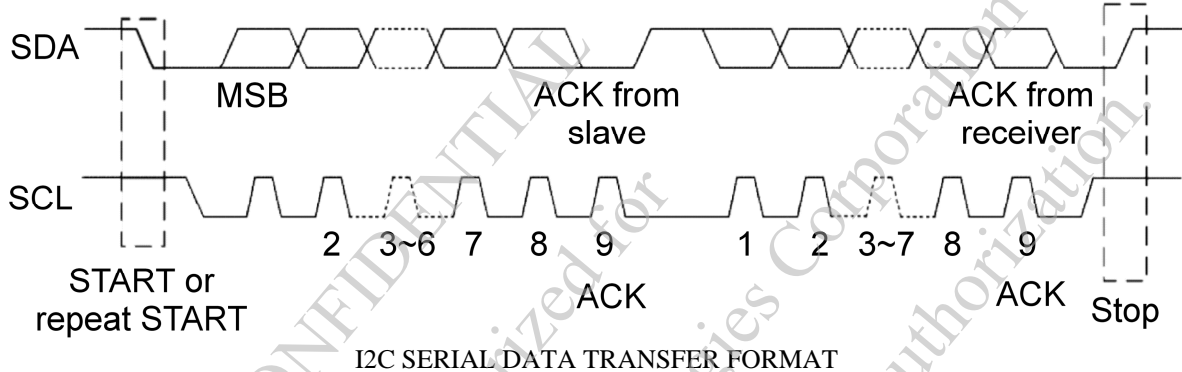

5.2.2 POWER SEQUENCE

ITEM	SYMBOL	MIN.	TYP.	MAX.	UNIT
RISE TIME FROM 0.1VDD TO 0.9VDD	Tris	—	—	5	ms
TIME OF RESETTING TO BE LOW BEFORE POWERING ON	Trtp	100	—	—	us
TIME OF STARTING TO REPORT POINT AFTER POWERING ON	Tpon	200	—	—	ms
RESET TIME AFTER VDD POWERING ON	Tvdr	1	—	—	ms
TIME OF STARTING TO REPORT POINT AFTER RESETTING	Trsi	200	—	—	ms
RESET TIME	Trst	2	—	—	ms

POWER RISE TIMING

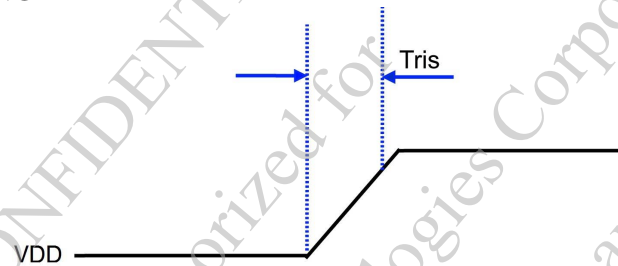

POWER ON / OFF TIMING

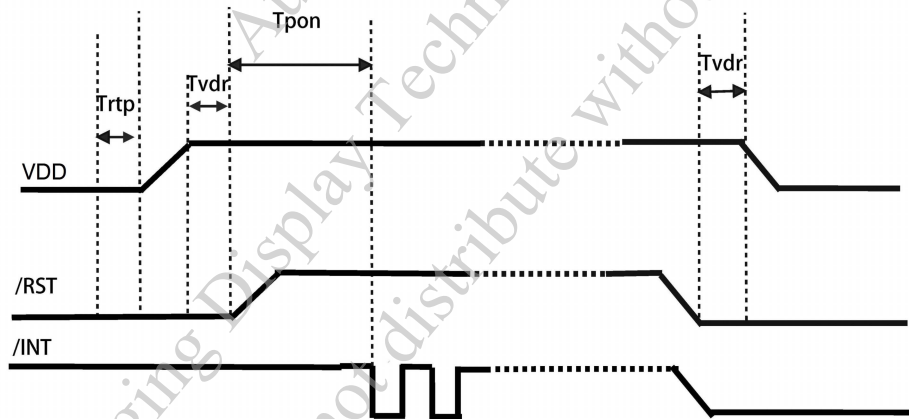

RESET SEQUENCE

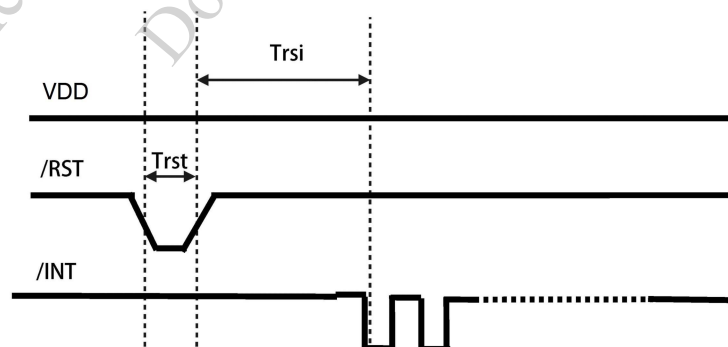

6. OPTICAL CHARACTERISTICS

6.1 OPTICAL CHARACTERISTICS

Ta = 25°C

ITEM	SYMBOL	CONDITION	MIN.	TYP.	MAX.	UNIT	REMARK	
VIEWING ANGLE	θ_{y+}	$CR \geq 10$	$\theta_x=0^\circ$	70	80	—	deg.	NOTE (2) NOTE (3)
	θ_{y-}			70	80	—		
	θ_{x+}		$\theta_y=0^\circ$	70	80	—		
	θ_{x-}			70	80	—		
CONTRAST RATIO (CENTER)	CR	$\theta_x=0^\circ, \theta_y=0^\circ$	640	800	—	—	NOTE (3)	
RESPONSE TIME	tr (rise)+ tf (fall)	$\theta_x=0^\circ, \theta_y=0^\circ$	—	30	40	msec	NOTE (4)	
COLOR CHROMATICITY (CENTER)	WHITE	Wx	(0.25)	(0.30)	(0.35)	—	NOTE (5)	
		Wy	(0.31)	(0.36)	(0.41)			
	RED	Rx	(0.55)	(0.60)	(0.65)	—		
		Ry	(0.31)	(0.36)	(0.41)			
	GREEN	Gx	(0.31)	(0.36)	(0.41)	—		
		Gy	(0.53)	(0.58)	(0.63)			
	BLUE	Bx	(0.09)	(0.14)	(0.19)	—		
		By	(0.06)	(0.11)	(0.16)			
THE BRIGHTNESS OF MODULE (CENTER)	B		(380)	(425)	—	cd/m ²	NOTE (6)	
THE BRIGHTNESS OF UNIFORMITY	—		70	—	—	%	NOTE (7)	

NOTE (1) : TEST CONDITION :

AFTER STABILIZING AND LEAVING THE PANEL ALONE AT A GIVEN TEMPERATURE FOR 30 MINUTES. MEASUREMENT SHOULD BE EXECUTED IN A STABLE, WINDLESS, AND DARK ROOM.

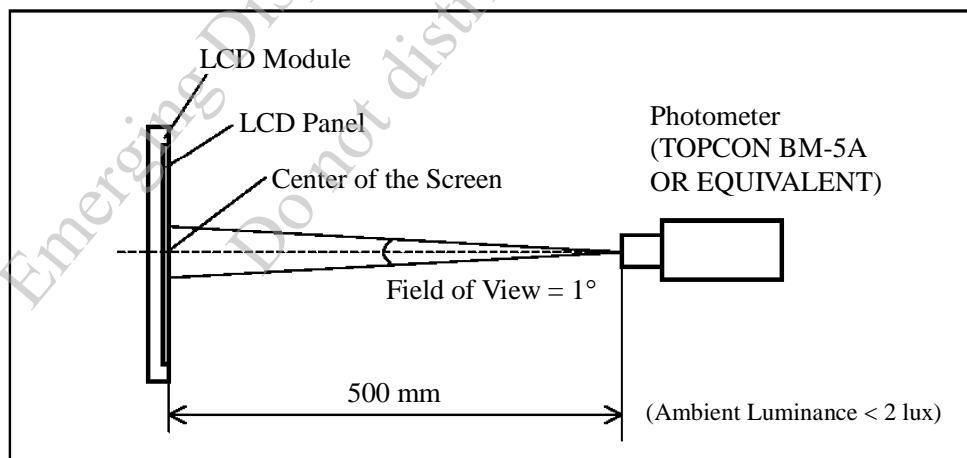

NOTE (2) : DEFINITION OF VIEWING ANGLE :

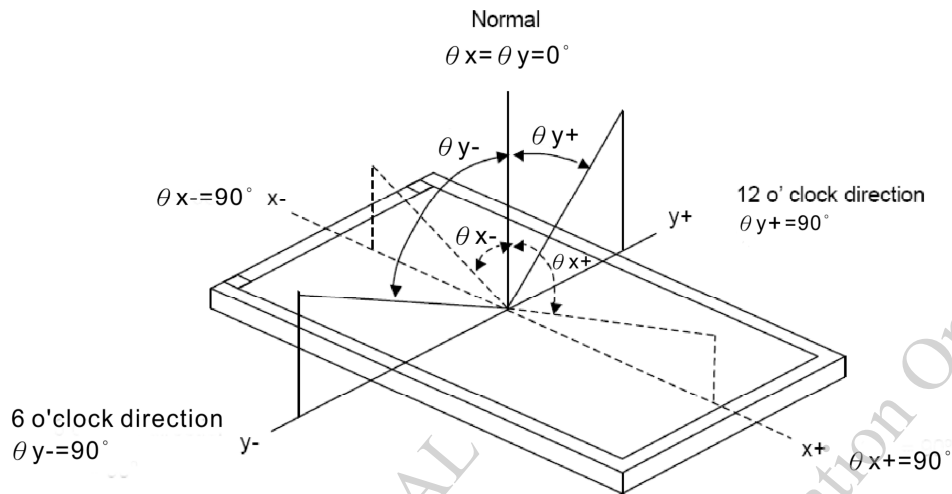

NOTE (3) : DEFINITION OF CONTRAST RATIO (CR) :

MEASURED AT THE CENTER POINT OF MODULE

$$\text{CONTRAST RATIO(CR)} = \frac{\text{BRIGHTNESS MEASURED WHEN LCD IS AT " WHITE STATE" }}{\text{BRIGHTNESS MEASURED WHEN LCD IS AT " BLACK STATE" }}$$

NOTE (4) : DEFINITION OF RESPONSE TIME : T_R AND T_F

THE FIGURE BELOW IS THE OUTPUT SIGNAL OF THE PHOTO DETECTOR.

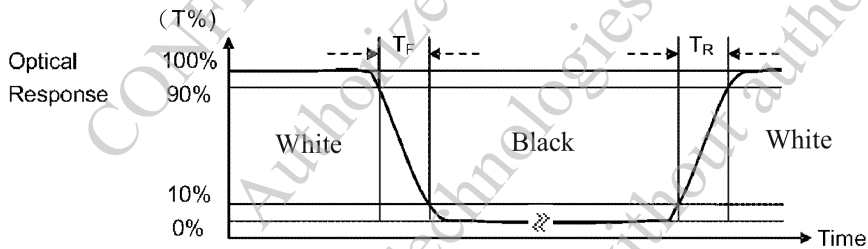

NOTE (5) : DEFINITION OF COLOR CHROMATICITY

(a)100% RGB PIXEL DATA TRANSMISSION WHEN ALL THE INPUT TERMINALS OF MODULE ARE ELECTRICALLY POWERED ON.

(b)MEASURED AT THE CENTER POINT OF MODULE

NOTE (6) : MEASURED THE BRIGHTNESS OF WHITE STATE AT CENTER POINT.

NOTE (7) : (a)DEFINITION OF BRIGHTNESS UNIFORMITY

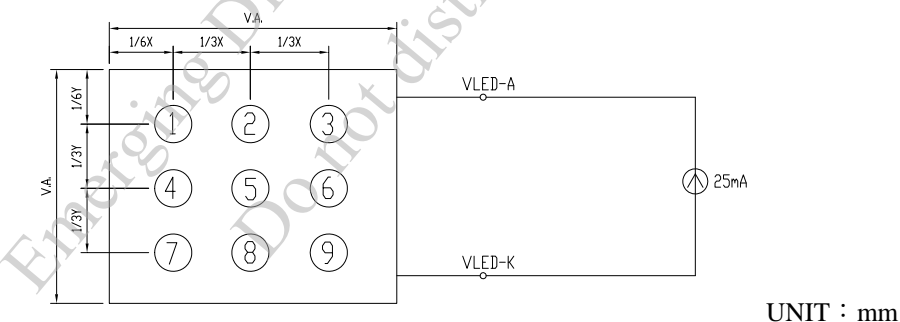

(b)THE BRIGHTNESS UNIFORMITY CALCULATING METHOD

$$\text{UNIFORMITY} : \frac{\text{MINIMUM BRIGHTNESS}}{\text{MAXIMUM BRIGHTNESS}} * 100\%$$

7. OUTLINE DIMENSIONS

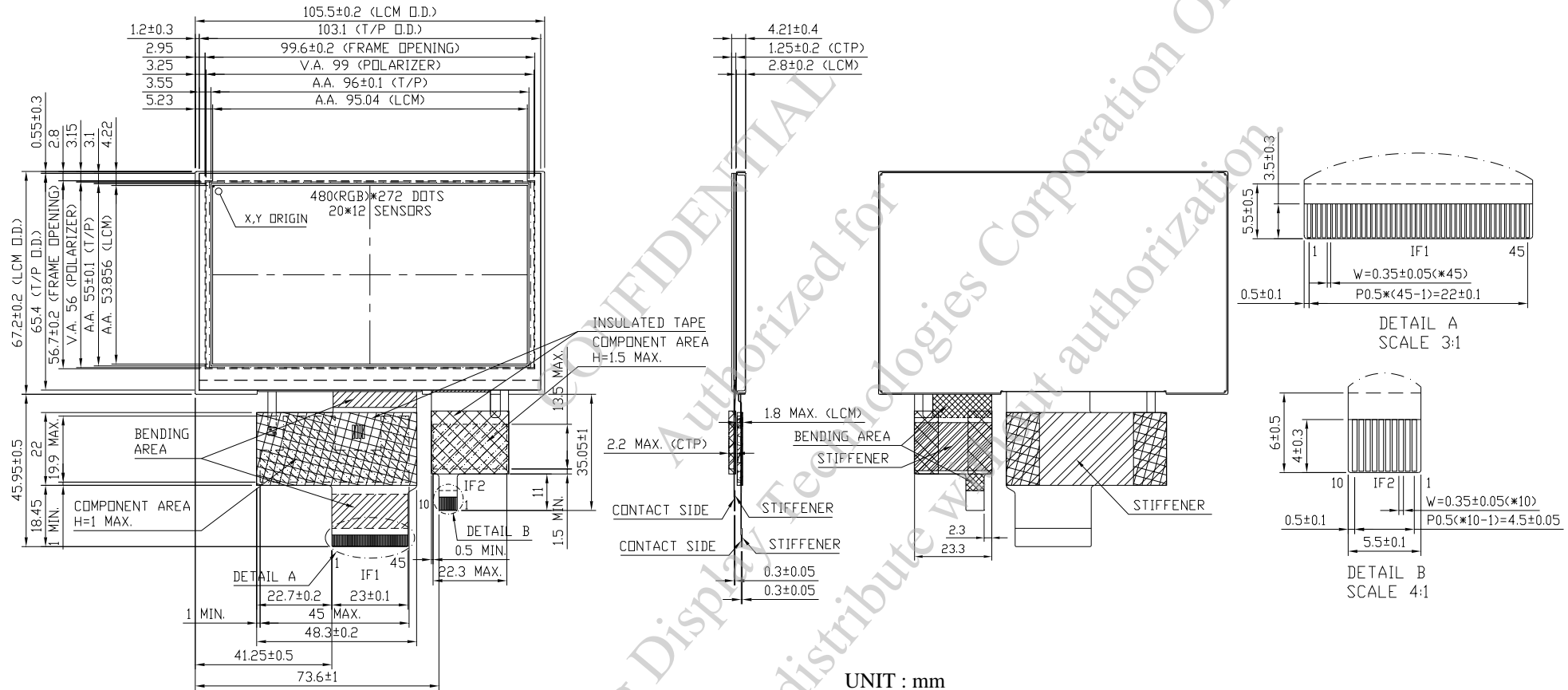

UNIT : mm
SCALE : NTS
NOT SPECIFIED TOLERANCE IS ±0.5mm
NOTE :
1.RECOMMEND MATCH CONNECTOR (IF1) : KYOCERA 04 6240 045 SERIES
2.RECOMMEND MATCH CONNECTOR (IF2) : KYOCERA 04 6240 010 S

8. BLOCK DIAGRAM

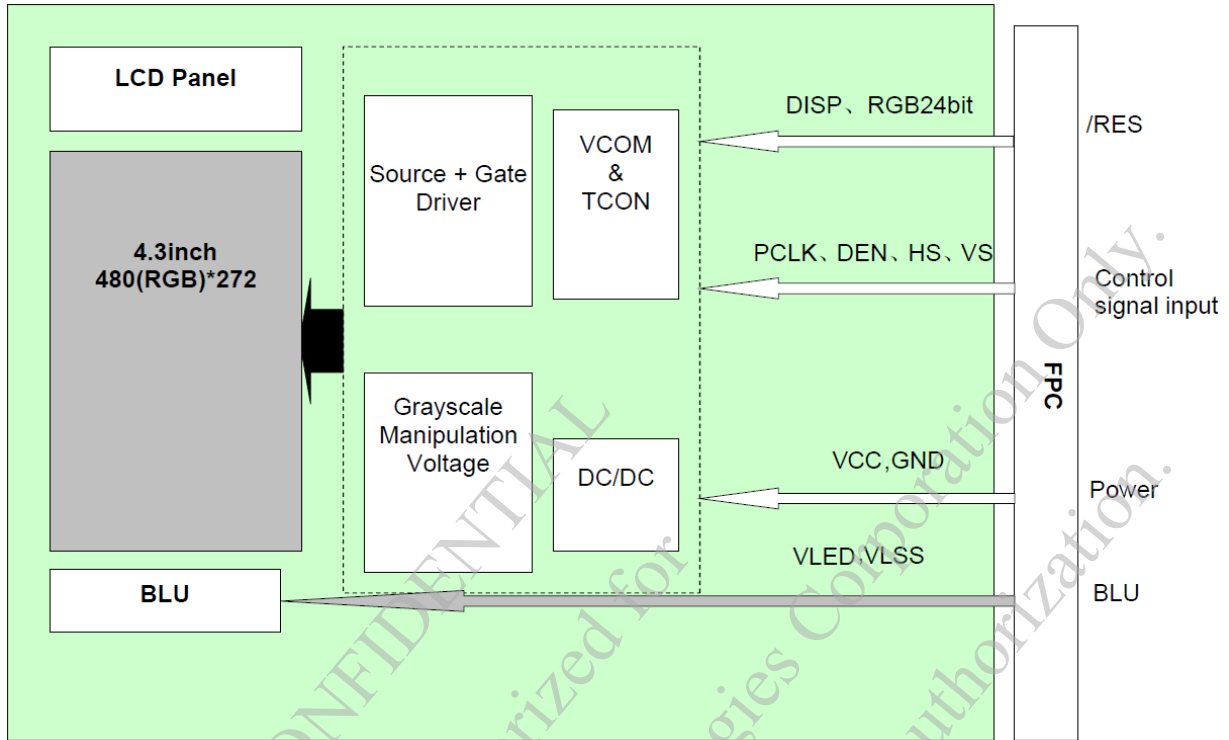

8.2 CTP

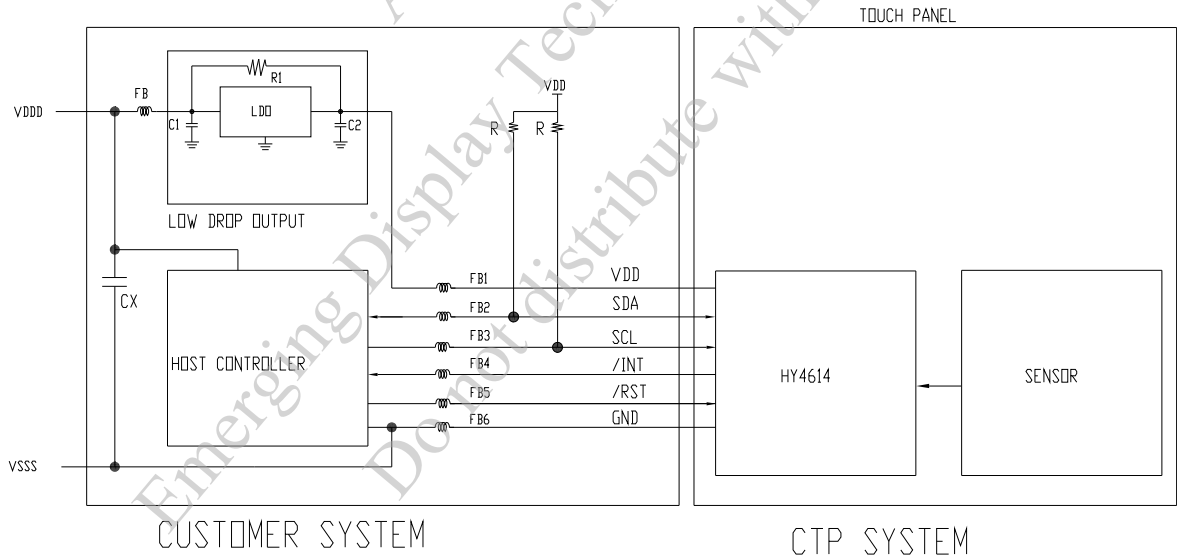

- NOTE (1) : THE STANDARD IIC COMMUNICATION INTERFACE, SUPREME SCL CLOCK IS 400 KHZ, SLAVE ADDRESS CAN BE SET UP, SUPPORTS VDD LEVEL POWER, NEEDS PULL HIGH RESISTANCE AND WE RECOMMEND THE PULL HIGH RESISTANCE IS 2.0K OHM.
- NOTE (2) : POWER SUPPLY SHALL BE CLEAN AND NOISE FREE. ADDITIONAL FILTERING OR A SEPARATE LDO (LOW DROP OUT) REGULATOR CAN BE REQUIRED. C1 AND C2 CAPACITORS RECOMMENDATION : 4.7μF OR 10 μF

9. DETAIL DRAWING OF DOT MATRIX

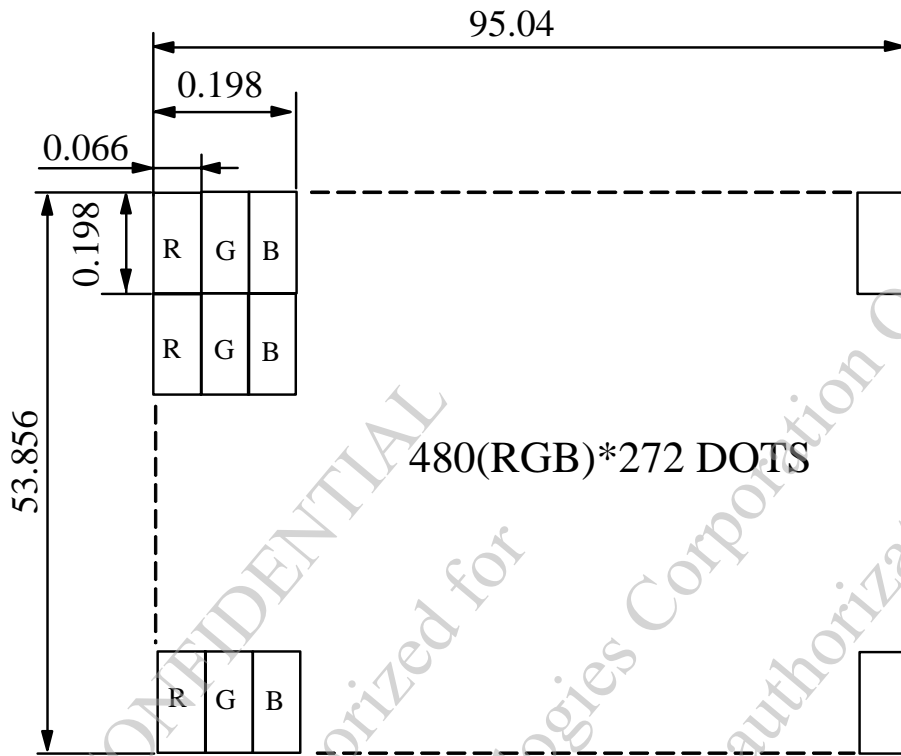

UNIT : mm

SCALE : NTS

NOT SPECIFIED TOLERANCE IS ± 0.1

DOTS MATRIX TOLERANCE IS ± 0.01

CONFIDENTIAL
Authorized for Emerging Display Technologies Corporation Only.
Do not distribute without authorization.

10. INTERFACE SIGNALS

10.1 LCD MODULE

PIN NO.	SYMBOL	FUNCTION
1	VSS	GROUND
2	VSS	GROUND
3	VCC	POWER SUPPLY VOLTAGE
4	VCC	POWER SUPPLY VOLTAGE
5	R0	RED DATA SIGNAL (LSB)
6	R1	RED DATA SIGNAL
7	R2	RED DATA SIGNAL
8	R3	RED DATA SIGNAL
9	R4	RED DATA SIGNAL
10	R5	RED DATA SIGNAL
11	R6	RED DATA SIGNAL
12	R7	RED DATA SIGNAL (MSB)
13	G0	GREEN DATA SIGNAL (LSB)
14	G1	GREEN DATA SIGNAL
15	G2	GREEN DATA SIGNAL
16	G3	GREEN DATA SIGNAL
17	G4	GREEN DATA SIGNAL
18	G5	GREEN DATA SIGNAL
19	G6	GREEN DATA SIGNAL
20	G7	GREEN DATA SIGNAL (MSB)
21	B0	BLUE DATA SIGNAL (LSB)
22	B1	BLUE DATA SIGNAL
23	B2	BLUE DATA SIGNAL
24	B3	BLUE DATA SIGNAL
25	B4	BLUE DATA SIGNAL
26	B5	BLUE DATA SIGNAL
27	B6	BLUE DATA SIGNAL
28	B7	BLUE DATA SIGNAL (MSB)
29	VSS	GROUND
30	DCLK	CLOCK SIGNAL; LATCHING DATA AT THE FALLING EDGE
31	DISP	DISPLAY CONTROL / STANDBY MODE SELECTION. DISP = "LOW" : STANDBY; DISP = "HIGH" : NORMAL DISPLAY(DEFAULT)
32	HSYNC	HORIZONTAL SYNC SIGNAL; NEGATIVE POLARITY

PIN NO.	SYMBOL	FUNCTION
33	VSYNC	VERTICAL SYNC SIGNAL; NEGATIVE POLARITY
34	DE	DATA INPUT ENABLE. ACTIVE HIGH TO ENABLE THE DATA INPUT.
35	CSB	SERIAL COMMUNICATION CHIP SELECT, INTERNAL PULL HIGH.
36	NC	NC
37	NC	NC
38	NC	NC
39	NC	NC
40	NC	NC
41	VSS	GROUND
42	VLSS	LED POWER SOURCE INPUT TERMINAL (CATHODE SIDE)
43	VLED	LED POWER SOURCE INPUT TERMINAL (ANODE SIDE)
44	SCL	SERIAL COMMUNICATION CLOCK INPUT, INTERNAL PULL LOW.
45	SDA	SERIAL COMMUNICATION DATA INPUT AND OUTPUT, INTERNAL PULL LOW.

RGB MODE SELECTION TABLE	DCLK	HSYNC	VSYNC	DE
SYNC-DE MODE	INPUT	INPUT	INPUT	INPUT
SYNC MODE	INPUT	INPUT	INPUT	GND
DE MODE	INPUT	GND	GND	INPUT

NOTE: "INPUT" MEANS THESE SIGNALS ARE DRIVEN BY HOST SIDE.

10.2 CTP MODULE

PIN NO.	SYMBOL	FUNCTION
1	GND	GROUND
2	VDD	POWER SUPPLY VOLTAGE
3	SCL	I2C CLOCK INPUT
4	NC	NON CONNECTION
5	SDA	I2C DATA INPUT AND OUTPUT
6	NC	NON CONNECTION
7	/RST	EXTERNAL RESET, LOW IS ACTIVE
8	NC	NON CONNECTION
9	/INT	EXTERNAL INTERRUPT TO THE HOST
10	GND	GROUND

11. POWER SUPPLY

11.1 POWER SUPPLY FOR LCM

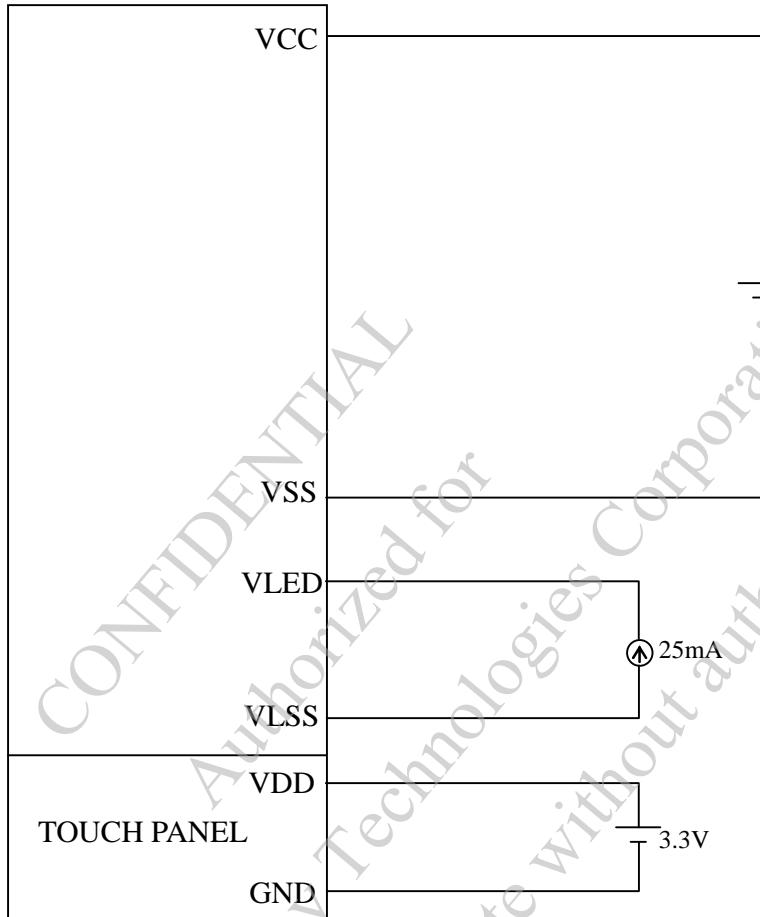

CONFIDENTIAL
Authorized for Emerging Display Technologies Corporation Only.
Do not distribute without authorization.

12. CAPACITIVE TOUCH PANEL SPECIFICATION

12.1 OPTICAL CHARACTERISTICS

ITEM	CONDITION	MIN.	TYP.	MAX.	UNIT
TRANSPARENCY NOTE (1)	Ta = 25°C	85	—	—	%

NOTE (1) : OPTICAL MEASUREMENT SHOULD BE EXECUTED AFTER PANEL IS SECURED.
MEASUREMENT PROCESS SHOULD BE EXECUTED IN A STABLE, WINDLESS, AND
DARK ROOM. OPTICAL SPECIFICATIONS SHOULD BE MEASURED BY
SPECTROPHOTOMETER.

12.2 HARDNESS

ITEM	DESCRIPTION
SURFACE HARDNESS	7H (MIN.)

12.3 DURABILITY

USING STEEL BALL AND FALLING ON TOUCH PANEL SURFACE, FROM THE
HEIGHT MUST PASS BELOW CONDITIONS :

ITEM	CONDITION	INSPECTION METHOD	DESCRIPTION
STEEL BALL DROP TEST	WEIGHT : 67g HEIGHT OF FALL : 30 cm	VISUAL INSPECTION	SIGN OF FRACTURE OR DAMAGE IS NOT ACCEPTABLE 3 TIMES/ 1 POINTS(CENTER), 25°C

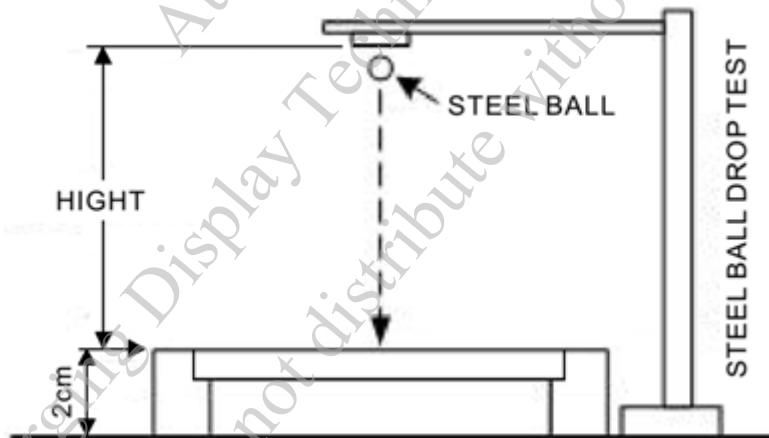

12.4 PROTOCOL

12.4.1 I2C READ

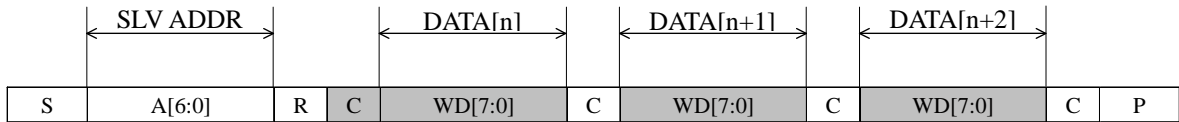

CHARACTER	DESCRIPTION
S	I2C START OR I2C RESTART
A[6:0]	SLAVE ADDRESS, THE VALUE CAN BE CUSTOMIZED
R	OPERATOR BYTE, SHOULD BE 1'b1, STANDS FOR READ
C	ACK SIGNAL
P	STOP SIGNAL (STOP SIGNAL IS OPTIONAL, RESTART SIGNAL IS ALSO OK FOR NEXT PACKET)

SLAVE ADDRESS=0x38

12.4.2 INTERRUPT SIGNAL FOR CTPM TO HOST

AS FOR STANDARD CTPM, HOST NEED TO USE BOTH INTERRUPT CONTROL SIGNAL AND SERIAL DATA INTERFACE TO GET THE TOUCH DATA.

HERE IS THE TIMING TO GET TOUCH DATA

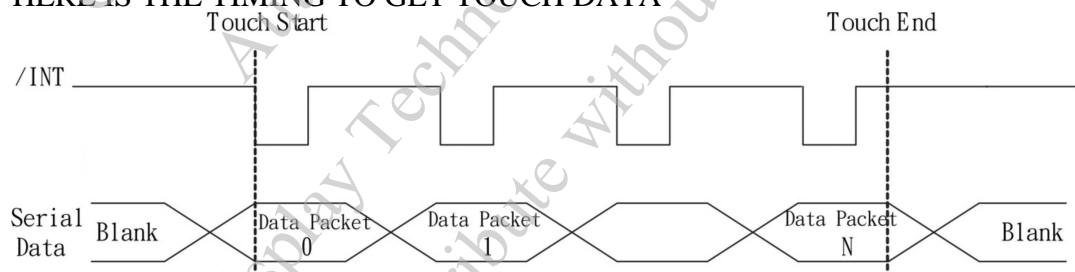

12.4.3 READ TOUCH DATA PACKET

WE DEFINED A CTPM PERIOD AS EACH CAPACITANCE DATA GATHERING AND DATA PROCESS, IN EACH CTPM, IF THERE IS A TOUCH DETECTS, THERE WILL WE A FAME OF TOUCH DATA. HOST CAN GET THE SPECIFIED FORMAT TOUCH DATA BY SERIAL DATA INTERFACE.

TOUCH DATA PACKET

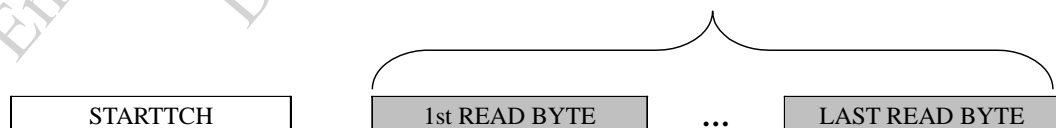

TOUCH DATA FORMAT

TOUCH DATA READ PROTOCOL

IN THIS MODE THE CTP IS FULLY FUNCTIONAL AS A TOUCH SCREEN CONTROLLER. READ AND WRITE ACCESS ADDRESS IS JUST LOGICAL ADDRESS WHICH IS NOT ENFORCED BY HARDWARE OR FIRMWARE. HERE IS THE OPERATING MODE REGISTER MAP.

ADDRESS	NAME	BIT7	BIT6	BIT5	BIT4	BIT3	BIT2	BIT1	BIT0	HOST ACCESS	
02h	TD_STATUS					NUMBER OF TOUCH POINTS[3:0]				R	
03h	TOUCH1_XH	1 st EVENT FLAG				1 st TOUCH X POSITION[11:8]				R	
04h	TOUCH1_XL	1 st TOUCH X POSITION[7:0]									R
05h	TOUCH1_YH	1 st TOUCH ID[3:0]						1 st TOUCH Y POSITION[11:8]			R
06h	TOUCH1_YL	1 st TOUCH Y POSITION[7:0]									R
07h											
08h											
09h	TOUCH2_XH	2 nd EVENT FLAG				2 nd TOUCH X POSITION[11:8]				R	
0Ah	TOUCH2_XL	2 nd TOUCH X POSITION[7:0]									R
0Bh	TOUCH2_YH	2 nd TOUCH ID[3:0]						2 nd TOUCH Y POSITION[11:8]			R
0Ch	TOUCH2_YL	2 nd TOUCH Y POSITION[7:0]									R
0Dh											R
0Eh											R
0Fh	TOUCH3_XH	3 rd EVENT FLAG				3 rd TOUCH X POSITION[11:8]				R	
10h	TOUCH3_XL	3 rd TOUCH X POSITION[7:0]									R
11h	TOUCH3_YH	3 rd TOUCH ID[3:0]						3 rd TOUCH Y POSITION[11:8]			R
12h	TOUCH3_YL	3 rd TOUCH Y POSITION[7:0]									R
13h											R
14h											R
15h	TOUCH4_XH	4 th EVENT FLAG				4 th TOUCH X POSITION[11:8]				R	
16h	TOUCH4_XL	4 th TOUCH X POSITION[7:0]									R
17h	TOUCH4_YH	4 th TOUCH ID[3:0]						4 th TOUCH Y POSITION[11:8]			R
18h	TOUCH4_YL	4 th TOUCH Y POSITION[7:0]									R
19h											R
1Ah											R
1Bh	TOUCH5_XH	5 th EVENT FLAG				5 th TOUCH X POSITION[11:8]				R	
1Ch	TOUCH5_XL	5 th TOUCH X POSITION[7:0]									R
1Dh	TOUCH5_YH	5 th TOUCH ID[3:0]						5 th TOUCH Y POSITION[11:8]			R
1Eh	TOUCH5_YL	5 th TOUCH Y POSITION[7:0]									R
1Fh											R
20h											R
A6h	ID_G_FIRMID	FIRMWARE ID								R	

TD_STATUS

THIS REGISTER IS THE TOUCH DATA STATUS REGISTER.

ADDRESS	BIT ADDRESS	REGISTER NAME	DESCRIPTION
02h	3:0	NUMBER OF TOUCH POINTS [3:0]	HOW MANY POINTS DETECTED. 1-5 IS VALID.
	7:4	NONE	NONE

TOUCHn_XH (n:1-5)

THIS REGISTER DESCRIBES MSB OF THE X COORDINATE OF THE NTH TOUCH POINT AND THE CORRESPONDING EVENT FLAG.

ADDRESS	BIT ADDRESS	REGISTER NAME	DESCRIPTION
03h ~ 1Bh	7:6	EVENT FLAG	00b: PUT DOWN 01b: PUT UP 10b: CONTACT 11b: RESERVED
	5:4	NONE	RESERVED
	3:0	TOUCH X POSITION [11:8]	MSB OF TOUCH X POSITION IN PIXELS

TOUCHn_XL (n:1-5)

THIS REGISTER DESCRIBES LSB OF THE X COORDINATE OF THE NTH TOUCH POINT.

ADDRESS	BIT ADDRESS	REGISTER NAME	DESCRIPTION
04h ~ 1Ch	7:0	TOUCH X POSITION [7:0]	LSB OF THE TOUCH X POSITION IN PIXELS

TOUCHn_YH (n:1-5)

THIS REGISTER DESCRIBES MSB OF THE Y COORDINATE OF THE NTH TOUCH POINT AND CORRESPONDING TOUCH ID.

ADDRESS	BIT ADDRESS	REGISTER NAME	DESCRIPTION
05h ~ 1Dh	7:4	TOUCH ID [3:0]	TOUCH ID OF TOUCH POINT
	3:0	TOUCH X POSITION [11:8]	MSB OF TOUCH Y POSITION IN PIXELS

TOUCHn_YL (n:1-5)

THIS REGISTER DESCRIBES LSB OF THE Y COORDINATE OF THE NTH TOUCH POINT.

ADDRESS	BIT ADDRESS	REGISTER NAME	DESCRIPTION
06h ~ 1Eh	7:0	TOUCH X POSITION [7:0]	LSB OF THE TOUCH Y POSITION IN PIXELS

ID_G_FIRMWARE_ID

THIS REGISTER DESCRIBES THE FIRMWARE ID OF THE APPLICATION

ADDRESS	BIT ADDRESS	REGISTER NAME	DESCRIPTION
A6h	7:0	ID_G_FIRMWARE_ID	FIRMWARE VERSION

13. INSPECTION CRITERION

13.1 APPLICATION

THIS INSPECTION STANDARD IS TO BE APPLIED TO THE LCD MODULE DELIVERED FROM EMERGING DISPLAY TECHNOLOGIES CORP.(E.D.T) TO CUSTOMERS

13.2 INSPECTION CONDITIONS

13.2.1 (1)OBSERVATION DISTANCE : 45±5cm

(2)VIEWING ANGLE : ±45°

±45° (FOR SECTION WITHIN VIEWING AREA), REFER TO FIG.A
90° (FOR SECTION OUTSIDE OF VIEWING AREA), REF TO FIG.B
PERPENDICULAR TO MODULE SURFACE

VIEWING ANGLE SHOULD BE SMALLER THAN 45°

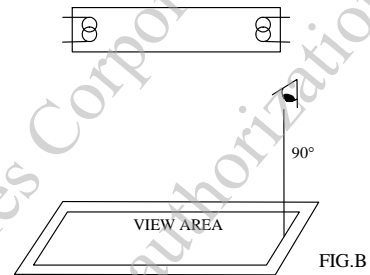
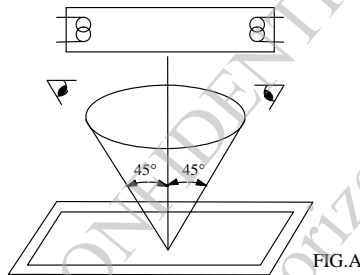

THE INSPECTION CRITERIA IS ACCORDING TO LINE OF SIGHT. INSPECTION SHALL BE MADE WITHIN THE HALF SECTION OF THE VIEWING CONE GENERATED BY LINE SEGMENT OF 45° WITH RESPECTS TO THE VERTICAL AXIS FROM CENTER VERTEX OF LCD, THE FLUORESCENT LAMP AND THE CONE AXIS MUST BE PERPENDICULAR TO THE LCD SURFACE.

IF THE DEFECTS ARE OUTSIDE OF VIEWING AREA, IT SHALL BE INSPECTED BY 90° WITH RESPECTS TO THE VERTICAL AXIS FROM EDGE OF VIEWING AREA.

13.2.2 ENVIRONMENT CONDITIONS :

AMBIENT TEMPERATURE		25±5°C
AMBIENT HUMIDITY		65 ± 20%RH
AMBIENT ILLUMINATION	COSMETIC INSPECTION	600~800 lux
	FUNCTIONAL INSPECTION	300~500 lux
INSPECTION TIME		10 secs

13.2.3 INSPECTION LOT

QUANTITY PER DELIVERY LOT FOR EACH MODEL

13.2.4 A SAMPLING INSPECTION SHALL BE MADE ACCORDING TO THE FOLLOWING PROVISIONS TO JUDGE THE ACCEPTABILITY

(a)APPLICABLE STANDARD :

ANSI/ ASQ Z1.4 NORMAL INSPECTION LEVEL II

(b)AQL : MAJOR DEFECT : AQL 0.65

MINOR DEFECT : AQL 1.0

13.3 DEFECTS CLASSIFICATION

TYPE OF DEFECT	INSPECTION ITEM	DEFECT FEATURE	AQL
MAJOR DEFECT	1.DISPLAY ON	<ul style="list-style-type: none"> • DEFECT TO MISS SPECIFIED DISPLAY FUNCTION, FOR ALL AND SPECIFIED DOTS EX: DISCONNECTION, SHORT CIRCUIT ETC 	0.65
	2.CTP FUNCTION	<ul style="list-style-type: none"> • NO FUNCTION • BROKEN LINE • FALSE TOUCH 	
	3.BACKLIGHT	<ul style="list-style-type: none"> • NO LIGHT • FLICKERING AND OTHER ABNORMAL ILLUMINATION 	
	4.DIMENSIONS	<ul style="list-style-type: none"> • SUBJECT TO INDIVIDUAL ACCEPTANCE SPECIFICATIONS 	
MINOR DEFECT	1.DISPLAY ZONE (VIEWING AREA)	<ul style="list-style-type: none"> • BLACK/WHITE SPOT / CIRCULAR TYPE • BUBBLES ON POLARIZER • NEWTON RING • BLACK/WHITE LINE / LINEAR TYPE • SCRATCH • CONTAMINATION • UNEVEN COLOR SPREAD 	1.0
	2.BEZEL ZONE	<ul style="list-style-type: none"> • STAINS • SCRATCHES • FOREIGN MATTER 	
	3.SOLDERING	<ul style="list-style-type: none"> • INSUFFICIENT SOLDER • SOLDERED IN INCORRECT POSITION • CONVEX SOLDERING SPOT • SOLDER BALLS • SOLDER SCRAPS 	
	4.DISPLAY ON (ALL ON)	<ul style="list-style-type: none"> • LIGHT LINE 	

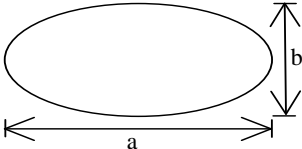
NO.	ITEM	CRITERIA																								
1	DISPLAY ON INSPECTION	1. INCORRECT PATTERN 2. MISSING SEGMENT 3. DIM SEGMENT 4. OPERATING VOLTAGE BEYOND SPEC																								
2	OVERALL DIMENSIONS	1. OVERALL DIMENSION BEYOND SPEC																								
3	DOT DEFECT	<p>1. INSPECTION PATTERN: FULL WHITE, FULL BLACK, RED, GREEN AND BLUE SCREENS.</p> <p>2.</p> <table border="1"> <thead> <tr> <th>ITEMS</th> <th>PERMISSIBLE NO.</th> </tr> </thead> <tbody> <tr> <td>BRIGHT DOT</td> <td>$N \leq 2$</td> </tr> <tr> <td>DARK DOT</td> <td>$N \leq 3$</td> </tr> <tr> <td>TOTAL BRIGHT AND DARK DOTS</td> <td>$N \leq 4$</td> </tr> </tbody> </table> <p>NOTE :</p> <p>(1)THE DEFINITION OF DOT : THE SIZE OF A DEFECTIVE DOT OVER 1/2 OF WHOLE DOT IS REGARDED AS ONE DEFECTIVE DOT.</p> <p>(2)BRIGHT DOT : DOTS APPEAR BRIGHT AND UNCHANGED IN SIZE IN WHICH LCD PANEL IS DISPLAYING UNDER BLACK PATTERN. THE BRIGHT DOT DEFECT MUST BE VISIBLE THROUGH 5% ND FILTER.</p> <p>(3)DARK DOT : DOTS APPEAR DARK AND UNCHANGED IN SIZE IN WHICH LCD PANEL IS DISPLAYING UNDER PURE RED, GREEN, BLUE PICTURE.</p>	ITEMS	PERMISSIBLE NO.	BRIGHT DOT	$N \leq 2$	DARK DOT	$N \leq 3$	TOTAL BRIGHT AND DARK DOTS	$N \leq 4$																
ITEMS	PERMISSIBLE NO.																									
BRIGHT DOT	$N \leq 2$																									
DARK DOT	$N \leq 3$																									
TOTAL BRIGHT AND DARK DOTS	$N \leq 4$																									
4	BUBBLES ON POLARIZER /SURFACE STAINS /DIRT/CF FAIL/SPOT	<table border="1"> <thead> <tr> <th></th> <th>AVERAGE DIAMETER (mm) : D</th> <th>PERMISSIBLE NO.</th> </tr> </thead> <tbody> <tr> <td rowspan="3">BUBBLE ON POLARIZER</td> <td>$D \leq 0.25$</td> <td>IGNORE</td> </tr> <tr> <td>$0.25 < D \leq 0.5$</td> <td>$N \leq 5$</td> </tr> <tr> <td>$0.5 < D$</td> <td>NONE</td> </tr> <tr> <td rowspan="3">SURFACE STAINS / DIRT ON POLARIZER</td> <td>$D < 0.25$</td> <td>IGNORE</td> </tr> <tr> <td>$0.25 < D \leq 0.4$</td> <td>$N \leq 3$</td> </tr> <tr> <td>$D > 0.4$</td> <td>NONE</td> </tr> <tr> <td rowspan="3">CF FAIL / SPOT</td> <td>$D < 0.1$</td> <td>IGNORE</td> </tr> <tr> <td>$0.1 < D \leq 0.3$</td> <td>$N \leq 3$</td> </tr> <tr> <td>$D > 0.3$</td> <td>NONE</td> </tr> </tbody> </table> <p>NOTE : (1)POLARIZER BUBBLE IS DEFINED AS THE BUBBLE APPEARS ON ACTIVE DISPLAY AREA. THE DEFECT OF POLARIZER BUBBLE SHALL BE IGNORED IF THE POLARIZER BUBBLE APPEARS ON THE OUTSIDE OF ACTIVE DISPLAY AREA.</p> <p>(2)THE EXTRANEOUS SUBSTANCE IS DEFINED AS IT CAN BE OBSERVED WHEN THE MODULE IS POWER ON.</p> <p>(3)THE DEFINITION OF AVERAGE DIAMETER, D IS DEFINED AS FOLLOWING. AVERAGE DIAMETER (D)=(a+b)/2</p> 		AVERAGE DIAMETER (mm) : D	PERMISSIBLE NO.	BUBBLE ON POLARIZER	$D \leq 0.25$	IGNORE	$0.25 < D \leq 0.5$	$N \leq 5$	$0.5 < D$	NONE	SURFACE STAINS / DIRT ON POLARIZER	$D < 0.25$	IGNORE	$0.25 < D \leq 0.4$	$N \leq 3$	$D > 0.4$	NONE	CF FAIL / SPOT	$D < 0.1$	IGNORE	$0.1 < D \leq 0.3$	$N \leq 3$	$D > 0.3$	NONE
	AVERAGE DIAMETER (mm) : D	PERMISSIBLE NO.																								
BUBBLE ON POLARIZER	$D \leq 0.25$	IGNORE																								
	$0.25 < D \leq 0.5$	$N \leq 5$																								
	$0.5 < D$	NONE																								
SURFACE STAINS / DIRT ON POLARIZER	$D < 0.25$	IGNORE																								
	$0.25 < D \leq 0.4$	$N \leq 3$																								
	$D > 0.4$	NONE																								
CF FAIL / SPOT	$D < 0.1$	IGNORE																								
	$0.1 < D \leq 0.3$	$N \leq 3$																								
	$D > 0.3$	NONE																								

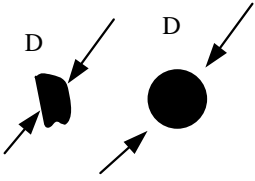
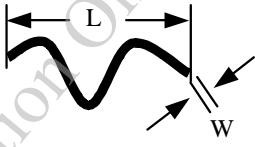
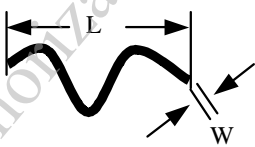
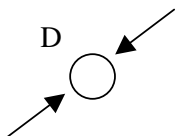
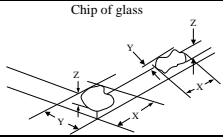
NO.	ITEM	CRITERIA												
5	BLACK/WHITE SPOT CIRCULAR TYPE	<p>THE FOLLOWING BLACK/WHITE SPOT ARE WITHIN THE VIEWING AREA. AVERAGE DIAMETER : D (mm)</p> <table border="1"> <thead> <tr> <th>SIZE D</th> <th>PERMISSIBLE NO.</th> </tr> </thead> <tbody> <tr> <td>D≤0.15</td> <td>IGNORE</td> </tr> <tr> <td>0.15<D≤0.3</td> <td>4</td> </tr> <tr> <td>0.3<D≤0.5</td> <td>2</td> </tr> <tr> <td>D>0.5</td> <td>0</td> </tr> </tbody> </table> <p>NOTE (1) : THE DISTANCE BETWEEN DEFECTS SHOULD BE MORE THAN 10mm APART.</p>		SIZE D	PERMISSIBLE NO.	D≤0.15	IGNORE	0.15<D≤0.3	4	0.3<D≤0.5	2	D>0.5	0	
SIZE D	PERMISSIBLE NO.													
D≤0.15	IGNORE													
0.15<D≤0.3	4													
0.3<D≤0.5	2													
D>0.5	0													
6	SCRATCH	<p>THE FOLLOWING SCRATCH IS WITHIN THE VIEWING AREA. WIDTH : W (mm) , LENGTH : L (mm)</p> <table border="1"> <thead> <tr> <th>SIZE W & L</th> <th>PERMISSIBLE NO.</th> </tr> </thead> <tbody> <tr> <td>W≤0.05</td> <td>IGNORE</td> </tr> <tr> <td>0.05<W≤0.08, L≤8</td> <td>3</td> </tr> <tr> <td>0.08<W≤0.1, L≤5</td> <td>3</td> </tr> <tr> <td>W>0.1</td> <td>0</td> </tr> </tbody> </table> <p>NOTE (1) : THE DISTANCE BETWEEN DEFECTS SHOULD BE MORE THAN 5mm APART.</p>		SIZE W & L	PERMISSIBLE NO.	W≤0.05	IGNORE	0.05<W≤0.08, L≤8	3	0.08<W≤0.1, L≤5	3	W>0.1	0	
SIZE W & L	PERMISSIBLE NO.													
W≤0.05	IGNORE													
0.05<W≤0.08, L≤8	3													
0.08<W≤0.1, L≤5	3													
W>0.1	0													
7	BLACK / WHITE LINE LINEAR TYPE / FOREIGN FIBER	<p>THE FOLLOWING BLACK LINE, WHITE LINE IS WITHIN THE VIEWING AREA. WIDTH : W (mm) , LENGTH : L (mm)</p> <table border="1"> <thead> <tr> <th>SIZE W & L</th> <th>PERMISSIBLE NO.</th> </tr> </thead> <tbody> <tr> <td>W≤0.05</td> <td>IGNORE</td> </tr> <tr> <td>0.05<W≤0.08, L≤8</td> <td>3</td> </tr> <tr> <td>0.08<W≤0.1, L≤5</td> <td>3</td> </tr> <tr> <td>W>0.1</td> <td>0</td> </tr> </tbody> </table> <p>NOTE (1) : THE DISTANCE BETWEEN DEFECTS SHOULD BE MORE THAN 5mm APART.</p>		SIZE W & L	PERMISSIBLE NO.	W≤0.05	IGNORE	0.05<W≤0.08, L≤8	3	0.08<W≤0.1, L≤5	3	W>0.1	0	
SIZE W & L	PERMISSIBLE NO.													
W≤0.05	IGNORE													
0.05<W≤0.08, L≤8	3													
0.08<W≤0.1, L≤5	3													
W>0.1	0													
8	BUBBLE / DENT FOR OPTICAL BONDING	<p>BUBBLES WITHIN VIEWING AREA. AVERAGE DIAMETER : D (mm)</p> <table border="1"> <thead> <tr> <th>SIZE D</th> <th>PERMISSIBLE NO.</th> </tr> </thead> <tbody> <tr> <td>D≤0.2</td> <td>IGNORE</td> </tr> <tr> <td>0.2<D≤0.3</td> <td>3</td> </tr> <tr> <td>0.3<D≤0.5</td> <td>2</td> </tr> <tr> <td>D>0.5</td> <td>0</td> </tr> </tbody> </table> <p>NOTE (1) : THE DISTANCE BETWEEN DEFECTS SHOULD BE MORE THAN 10mm APART.</p>		SIZE D	PERMISSIBLE NO.	D≤0.2	IGNORE	0.2<D≤0.3	3	0.3<D≤0.5	2	D>0.5	0	
SIZE D	PERMISSIBLE NO.													
D≤0.2	IGNORE													
0.2<D≤0.3	3													
0.3<D≤0.5	2													
D>0.5	0													
9	CHIPPING	<table border="1"> <tr> <td>CORNER</td> <td>$X + Y \leq 4mm \cdot Z \leq t$ (t : THICKNESS)</td> </tr> <tr> <td>EDGE</td> <td>$X \leq 6mm, Y \leq 1mm, Z < t$ (t : THICKNESS)</td> </tr> </table>	CORNER	$X + Y \leq 4mm \cdot Z \leq t$ (t : THICKNESS)	EDGE	$X \leq 6mm, Y \leq 1mm, Z < t$ (t : THICKNESS)								
CORNER	$X + Y \leq 4mm \cdot Z \leq t$ (t : THICKNESS)													
EDGE	$X \leq 6mm, Y \leq 1mm, Z < t$ (t : THICKNESS)													
10	CRACKED GLASS	NOT ACCEPTABLE												
11	LINE DEFECT ON DISPLAY	OBVIOUS VERTICAL OR HORIZONTAL LINE DEFECT IS NOT ALLOWED.												
12	MURA ON DISPLAY	IT'S ACCEPTABLE, IF MURA IS SLIGHT VISIBLE THROUGH 6% ND FILTER.												
13	UNEVEN COLOR SPREAD, COLORATION	TO BE DETERMINED BASED UPON THE LIMITED SAMPLE.												
14	BEZEL APPEARANCE	<p>1. BEZEL MAY NOT HAVE RUST, BE DEFORMED OR HAVE FINGER PRINTS STAINS OF OTHER CONTAMINATION.</p> <p>2. BEZEL MUST COMPLY WITH JOB SPECIFICATIONS.</p>												

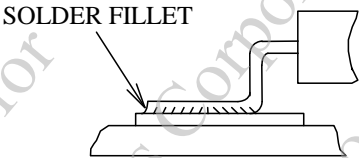
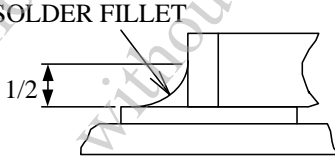
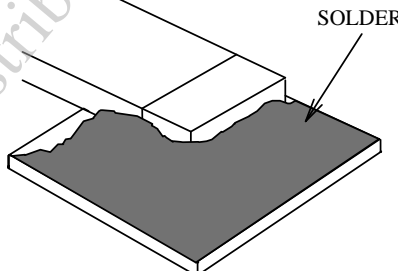
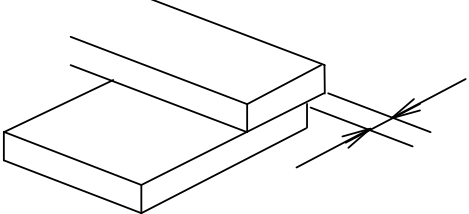
NO.	ITEM	CRITERIA
15	PCB	<ol style="list-style-type: none"> 1. THERE MAY NOT BE MORE THAN 2mm OF SEALANT OUTSIDE THE SEAL AREA ON THE PCB, AND THERE SHOULD BE NO MORE THAN THREE PLACES. 2. NO OXIDATION OR CONTAMINATION ON PCB TERMINALS. 3. PARTS ON PCB MUST BE THE SAME AS ON THE PRODUCTION CHARACTERISTIC CHART. THERE SHOULD BE NO WRONG PARTS, MISSING PARTS OR EXCESS PARTS. 4. THE JUMPER ON THE PCB SHOULD CONFORM TO THE PRODUCT CHARACTERISTIC CHART. 5. IF SOLDER GETS ON BEZEL TAB PADS, LED PAD, ZEBRA PAD OR SCREW HOLD PAD; MAKE SURE IT IS SMOOTHED DOWN.
16	SOLDERING	<ol style="list-style-type: none"> 1. NO SOLDERING FOUND ON THE SPECIFIED PLACE 2. INSUFFICIENT SOLDER <ol style="list-style-type: none"> (a)LSI, IC A POOR WETTING OF SOLDER IS BETWEEN LOWER BEND OR "HEEL" OF LEAD AND PAD  (b)CHIP COMPONENT <ul style="list-style-type: none"> · SOLDER IS LESS THAN 50% OF SIDES AND FRONT FACE WETTING  · SOLDER WETS 3 SIDES OF TERMINAL, BUT LESS THAN 25% OF SIDES AND FRONT SURFACE AREA ARE COVERED  3. PARTS ALIGNMENT <ol style="list-style-type: none"> (a)LSI, IC LEAD WIDTH IS MORE THAN 50% BEYOND PAD OUTLINE 

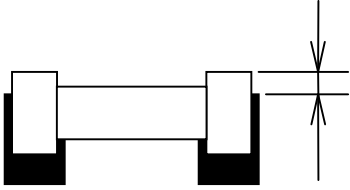
NO.	ITEM	CRITERIA
16	SOLDERING	<p>(b)CHIP COMPONENT COMPONENT IS OFF CENTER, AND MORE THAN 50% OF THE LEADS IS OFF THE PAD OUTLINE</p>  <p>4. NO UNMELTED SOLDER PASTE MAY BE PRESENT ON THE PCB. 5. NO COLD SOLDER JOINTS, MISSING SOLDER CONNECTIONS, OXIDATION OR ICICLE. 6. NO RESIDUE OR SOLDER BALLS ON PCB. 7. NO SHORT CIRCUITS IN COMPONENTS ON PCB.</p>
17	BACKLIGHT	<p>1. NO LIGHT 2. FLICKERING AND OTHER ABNORMAL ILLUMINATION 3. SPOTS OR SCRATCHES THAT APPEAR WHEN LIT MUST BE JUDGED USING LCD SPOT, LINES AND CONTAMINATION STANDARDS. 4. BACKLIGHT DOESN'T LIGHT OR COLOR IS WRONG.</p>
18	GENERAL APPEARANCE	<p>1. NO OXIDATION, CONTAMINATION, CURVES OR, BENDS ON INTERFACE PIN (OLB) OF TCP. 2. NO CRACKS ON INTERFACE PIN (OLB) OF TCP. 3. NO CONTAMINATION, SOLDER RESIDUE OR SOLDER BALLS ON PRODUCT. 4. THE IC ON THE TCP MAY NOT BE DAMAGED, CIRCUITS. 5. THE UPPERMOST EDGE OF THE PROTECTIVE STRIP ON THE INTERFACE PIN MUST BE PRESENT OR LOOK AS IF IT CAUSE THE INTERFACE PIN TO SEVER. 6. THE RESIDUAL ROSIN OR TIN OIL OF SOLDERING (COMPONENT OR CHIP COMPONENT) IS NOT BURNED INTO BROWN OR BLACK COLOR. 7. SEALANT ON TOP OF THE ITO CIRCUIT HAS NOT HARDENED. 8. PIN TYPE MUST MATCH TYPE IN SPECIFICATION SHEET. 9. LCD PIN LOOSE OR MISSING PINS. 10. PRODUCT PACKAGING MUST BE THE SAME AS SPECIFIED ON PACKAGING SPECIFICATION SHEET. 11. PRODUCT DIMENSION AND STRUCTURE MUST CONFORM TO PRODUCT SPECIFICATION SHEET. 12. THE APPEARANCE OF HEAT SEAL SHOULD NOT ADMIT ANY DIRT AND BREAK.</p>

NOTE :

- 1.FOR ANY SPOTS OR LINES, WHICH ARE NOT OBSERVED UNDER APPROPRIATE PANEL OPERATING CONDITION ARE DEEMED ACCEPTABLE.
- 2.THE FOREIGN MATERIALS THAT CAN BE BLOWN OUT BY AIR AND REMOVED BY WET CLEANING ARE NOT REGARDED AS DEFECTS.

14. RELIABILITY TEST

14.1 STANDARD SPECIFICATIONS FOR RELIABILITY OF LCD MODULE

NO.	ITEM	DESCRIPTION
1	HIGH TEMPERATURE OPERATION	THE SAMPLE SHOULD BE ALLOWED TO STAND AT +70°C FOR 240 HRS
2	LOW TEMPERATURE OPERATION	THE SAMPLE SHOULD BE ALLOWED TO STAND AT -20°C FOR 240 HRS
3	HIGH TEMPERATURE STORAGE	THE SAMPLE SHOULD BE ALLOWED TO STAND AT +80°C FOR 240 HRS
4	LOW TEMPERATURE STORAGE	THE SAMPLE SHOULD BE ALLOWED TO STAND AT -30°C FOR 240 HRS
5	HIGH TEMPERATURE /HUMIDITY TEST STORAGE	THE SAMPLE SHOULD BE ALLOWED TO STAND AT 60°C, 90% RH 240 HRS
6	THERMAL SHOCK (NOT OPERATED)	<p>THE SAMPLE SHOULD BE ALLOWED TO STAND THE FOLLOWING 10 CYCLES OF OPERATION:</p> <p>The diagram illustrates a thermal shock cycle. It starts at -30°C, ramps up to +80°C over 30 minutes, dwells at +80°C for 3 minutes, ramps down to -30°C over 30 minutes, and dwells at -30°C for 3 minutes. This sequence is repeated 10 times. The total duration of one cycle is 72 minutes.</p>
7	ESD (ELECTROSTATIC DISCHARGE) (NOT OPERATED)	AIR DISCHARGE ± 12KV CONTACT DISCHARGE ± 8KV ACCORDING TO IEC-61000-4-2

NOTE (1) : THE TEST SAMPLES HAVE RECOVERY TIME FOR 2 HOURS AT ROOM TEMPERATURE BEFORE THE FUNCTION CHECK. IN THE STANDARD CONDITIONS, THERE IS NO DISPLAY FUNCTION NG ISSUE OCCURRED.

14.2 TESTING CONDITIONS AND INSPECTION CRITERIA

FOR THE FINAL TEST THE TESTING SAMPLE MUST BE STORED AT ROOM TEMPERATURE FOR 24 HOURS, AFTER THE TESTS LISTED IN TABLE 14.1, STANDARD SPECIFICATIONS FOR RELIABILITY HAVE BEEN EXECUTED IN ORDER TO ENSURE STABILITY.

NO.	ITEM	TEST MODEL	INSPECTION CRITERIA
1	CURRENT CONSUMPTION	REFER TO SPECIFICATION	THE CURRENT CONSUMPTION SHOULD CONFORM TO THE PRODUCT SPECIFICATION.
2	CONTRAST	REFER TO SPECIFICATION	AFTER THE TESTS HAVE BEEN EXECUTED, THE CONTRAST MUST BE LARGER THAN HALF OF ITS INITIAL VALUE PRIOR TO THE TESTS.
3	APPEARANCE	VISUAL INSPECTION	DEFECT FREE

15. CAUTION

15.1 OPERATION

- 15.1.1 DO NOT CONNECT OR DISCONNECT MODULES TO OR FROM THE MAIN SYSTEM WHILE POWER IS BEING SUPPLIED.
- 15.1.2 USE THE MODULE WITHIN SPECIFIED TEMPERATURE ; LOWER TEMPERATURE CAUSES THE RETARDATION OF BLINKING SPEED OF THE DISPLAY ; HIGHER TEMPERATURE MAKES OVERALL DISPLAY DISCOLOR. WHEN THE TEMPERATURE RETURNS TO NORMALITY, THE DISPLAY WILL OPERATE NORMALLY .
- 15.1.3 ADJUST THE LC DRIVING VOLTAGE TO OBTAIN THE OPTIMUM CONTRAST.
- 15.1.4 POWER ON SEQUENCE INPUT SIGNALS SHOULD NOT BE SUPPLIED TO LCD MODULE BEFORE POWER SUPPLY VOLTAGE IS APPLIED AND REACHES THE SPECIFIED VALUE .
IF ABOVE SEQUENCE IS NOT FOLLOWED , CMOS LSIS OF LCD MODULES MAY BE DAMAGED DUE TO LATCH - UP PROBLEM .
- 15.1.5 NOT ALLOWED TO INFLICT ANY EXTERNAL STRESS AND TO CAUSE ANY MECHANICAL INTERFERENCE ON THE BENDING AREA OF FPC DURING THE TAIL BENDING BACKWARDS!
DO NOT STRESS FPC AND IC ON THE MODULE!

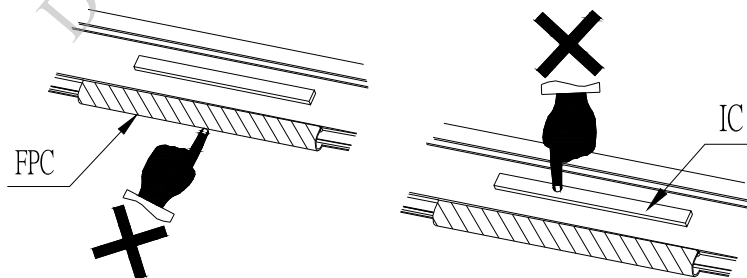

15.2 HANDLING

- 15.2.1 USE A GROUNDED SOLDERING IRON WHEN SOLDERING CONNECTOR I/O TERMINALS . FOR SOLDERING OR REPAIRING, TAKE PRECAUTION AGAINST THE TEMPERATURE OF THE SOLDERING IRON AND THE SOLDERING TIME TO PREVENT PEELING OFF THE THROUGH-HOLE-PAD .
- 15.2.2 DO NOT DISASSEMBLE . EDT SHALL NOT BE HELD RESPONSIBLE IF THE MODULE IS DISASSEMBLED AND UPON THE REASSEMBLY THE MODULE FAILED .
- 15.2.3 DO NOT CHARGE STATIC ELECTRICITY , AS THE CIRCUIT OF THIS MODULE CONTAINS CMOS LSIS. A WORKMAN'S BODY SHOULD ALWAYS BE STATIC-PROTECTED BY USE OF AN ESD STRAP. WORKING CLOTHES FOR SUCH PERSONNEL SHOULD BE OF STATIC-PROTECTED MATERIAL .
- 15.2.4 ALWAYS GROUND THE ELECTRICALLY-POWERED DRIVER BEFORE USING IT TO INSTALL THE LCD MODULE. WHILE CLEANING THE WORK STATION BY VACUUM CLEANER, DO NOT BRING THE SUCKING MOUTH NEAR THE MODULE ; STATIC ELECTRICITY OF THE ELECTRICALLY-POWERED DRIVER OR THE VACUUM CLEANER MAY DESTROY THE MODULE .
- 15.2.5 DON'T GIVE EXTERNAL SHOCK.
- 15.2.6 DON'T APPLY EXCESSIVE FORCE ON THE SURFACE.
- 15.2.7 LIQUID CRYSTAL IN LCD IS HAZARDOUS SUBSTANCE. MUST NOT LICK AND SWALLOW.
WHEN THE LIQUID IS ATTACH TO YOUR, SKIN, CLOTH ETC.
WASH IT OUT THOROUGHLY AND IMMEDIATELY.
- 15.2.8 DON'T OPERATE IT ABOVE THE ABSOLUTE MAXIMUM RATING.
- 15.2.9 STORAGE IN A CLEAN ENVIRONMENT, FREE FROM DUST, ACTIVE GAS, AND SOLVENT.
- 15.2.10 STORE WITHOUT ANY PHYSICAL LOAD.
- 15.2.11 REWIRING: NO MORE THAN 3 TIMES.