

EXAMINED BY : <i>Dan Kao</i>	EMERGING DISPLAY TECHNOLOGIES CORPORATION	FILE NO . CAS-0009508
APPROVED BY: <i>Justin Horng</i>		ISSUE :OCT.03, 2023
		TOTAL PAGE : 22
		VERSION : 4

CUSTOMER ACCEPTANCE SPECIFICATIONS

MODEL NO. :

ET156025LDXA

(RoHS)

FOR MESSRS :

CUSTOMER'S APPROVAL

DATE :

BY :

DOC . FIRST ISSUE

FEB.22, 2023

RECORDS OF REVISION

DATE	REVISED PAGE NO.	SUMMARY																																																															
APR.21, 2023	1	1.1 DATA SHEETS FOR LCD MODULE CONTROLLER/DRIVER PLEASE REFER TO:TBD→HX-8255B																																																															
		2. MECHANICAL SPECIFICATIONS (3)MODULE SIZE:363.8W * 215.9H * 15.35D(MAX.) mm→ 363.8W * 215.9H * 13D(MAX.) mm																																																															
	9	7. OUTLINE DIMENSIONS MARK△: MODIFY B/L FPC C/N & FRAME & PCB1 NOTE ADD TOP VIEW																																																															
SEP.21, 2023	1	2. MECHANICAL SPECIFICATIONS (12) INTERFACE MODE: LVDS→LVDS(VESA) (13) WEIGHT: TBD→755g																																																															
	2	3.1 ELECTRICAL ABSOLUTE MAXIMUM RATINGS <table border="1" style="width:100%; border-collapse: collapse;"> <thead> <tr> <th>ITEM</th> <th>SYMBOL</th> <th>MIN.</th> <th>MAX.</th> </tr> </thead> <tbody> <tr> <td>POWER SUPPLY VOLTAGE</td> <td>VDD-VSS</td> <td>(-0.3)</td> <td>(4.0)</td> </tr> <tr> <td>POWER SUPPLY VOLTAGE FOR LED DRIVER</td> <td>VBL+-VSS</td> <td>(-0.3)</td> <td>(27)</td> </tr> </tbody> </table> <p style="text-align:center;">↓</p> <table border="1" style="width:100%; border-collapse: collapse;"> <thead> <tr> <th>ITEM</th> <th>SYMBOL</th> <th>MIN.</th> <th>MAX.</th> </tr> </thead> <tbody> <tr> <td>POWER SUPPLY VOLTAGE</td> <td>VDD-VSS</td> <td>-0.3</td> <td>4.0</td> </tr> <tr> <td>POWER SUPPLY VOLTAGE FOR LED DRIVER</td> <td>VBL+-VSS</td> <td>-0.3</td> <td>27</td> </tr> </tbody> </table>	ITEM	SYMBOL	MIN.	MAX.	POWER SUPPLY VOLTAGE	VDD-VSS	(-0.3)	(4.0)	POWER SUPPLY VOLTAGE FOR LED DRIVER	VBL+-VSS	(-0.3)	(27)	ITEM	SYMBOL	MIN.	MAX.	POWER SUPPLY VOLTAGE	VDD-VSS	-0.3	4.0	POWER SUPPLY VOLTAGE FOR LED DRIVER	VBL+-VSS	-0.3	27																																							
	ITEM	SYMBOL	MIN.	MAX.																																																													
POWER SUPPLY VOLTAGE	VDD-VSS	(-0.3)	(4.0)																																																														
POWER SUPPLY VOLTAGE FOR LED DRIVER	VBL+-VSS	(-0.3)	(27)																																																														
ITEM	SYMBOL	MIN.	MAX.																																																														
POWER SUPPLY VOLTAGE	VDD-VSS	-0.3	4.0																																																														
POWER SUPPLY VOLTAGE FOR LED DRIVER	VBL+-VSS	-0.3	27																																																														
	3.2 ENVIRONMENTAL ABSOLUTE MAXIMUM RATINGS NOTE(4): WHEN THE LCD MODULE IS OPERATED AT AMBIENT TEMPERATURE 80°C, THE PWM DUTY CYCLE OF THE LED BACKLIGHT SHOULD BE ADJUSTED TO BE LESS THAN TBD. IF THE MODULE IS OPERATED AT A HIGHER DUTY CYCLE THAN TBD, THEN THERE IS A POSSIBILITY OF DISTORTION AND IRREGULARITY OF THE PICTURE DUE TO LIQUID CRYSTAL BEHAVIOR.→ WHEN THE LCD MODULE IS OPERATED AT AMBIENT TEMPERATURE 60°C, THE PWM DUTY CYCLE OF THE LED BACKLIGHT SHOULD BE ADJUSTED TO BE LESS THAN 50%. IF THE MODULE IS OPERATED AT A HIGHER DUTY CYCLE THAN 50%, THEN THERE IS A POSSIBILITY OF DISTORTION AND IRREGULARITY OF THE PICTURE DUE TO LIQUID CRYSTAL BEHAVIOR.																																																																
3	4.1 ELECTRICAL CHARACTERISTICS <table border="1" style="width:100%; border-collapse: collapse;"> <thead> <tr> <th>ITEM</th> <th>MIN.</th> <th>TYP.</th> <th>MAX.</th> </tr> </thead> <tbody> <tr> <td>POWER SUPPLY VOLTAGE</td> <td>(3.0)</td> <td>(3.3)</td> <td>(3.6)</td> </tr> <tr> <td>RUSH CURRENT</td> <td>—</td> <td>—</td> <td>(1.5)</td> </tr> <tr> <td>ALLOWABLE LOGIC/LCD DRIVE RIPPLE VOLTAGE</td> <td>—</td> <td>—</td> <td>(200)</td> </tr> <tr> <td>POWER SUPPLY CURRENT</td> <td>—</td> <td>—</td> <td>(454)</td> </tr> <tr> <td>POWER SUPPLY VOLTAGE FOR LED DRIVER</td> <td>(10.8)</td> <td>(12)</td> <td>(13.2)</td> </tr> <tr> <td>POWER SUPPLY CURRENT FOR LED DRIVER</td> <td>—</td> <td>(2)</td> <td>(3)</td> </tr> <tr> <td>LED LIFE TIME</td> <td>(50K)</td> <td>—</td> <td>—</td> </tr> </tbody> </table> <p style="text-align:center;">↓</p> <table border="1" style="width:100%; border-collapse: collapse;"> <thead> <tr> <th>ITEM</th> <th>MIN.</th> <th>TYP.</th> <th>MAX.</th> </tr> </thead> <tbody> <tr> <td>POWER SUPPLY VOLTAGE</td> <td>3.0</td> <td>3.3</td> <td>3.6</td> </tr> <tr> <td>RUSH CURRENT</td> <td>—</td> <td>—</td> <td>1.5</td> </tr> <tr> <td>ALLOWABLE LOGIC/LCD DRIVE RIPPLE VOLTAGE</td> <td>—</td> <td>—</td> <td>200</td> </tr> <tr> <td>POWER SUPPLY CURRENT</td> <td>—</td> <td>350</td> <td>454</td> </tr> <tr> <td>POWER SUPPLY VOLTAGE FOR LED DRIVER</td> <td>10.8</td> <td>12</td> <td>13.2</td> </tr> <tr> <td>POWER SUPPLY CURRENT FOR LED DRIVER</td> <td>—</td> <td>2</td> <td>2.6</td> </tr> <tr> <td>LED LIFE TIME</td> <td>50K</td> <td>—</td> <td>—</td> </tr> </tbody> </table>	ITEM	MIN.	TYP.	MAX.	POWER SUPPLY VOLTAGE	(3.0)	(3.3)	(3.6)	RUSH CURRENT	—	—	(1.5)	ALLOWABLE LOGIC/LCD DRIVE RIPPLE VOLTAGE	—	—	(200)	POWER SUPPLY CURRENT	—	—	(454)	POWER SUPPLY VOLTAGE FOR LED DRIVER	(10.8)	(12)	(13.2)	POWER SUPPLY CURRENT FOR LED DRIVER	—	(2)	(3)	LED LIFE TIME	(50K)	—	—	ITEM	MIN.	TYP.	MAX.	POWER SUPPLY VOLTAGE	3.0	3.3	3.6	RUSH CURRENT	—	—	1.5	ALLOWABLE LOGIC/LCD DRIVE RIPPLE VOLTAGE	—	—	200	POWER SUPPLY CURRENT	—	350	454	POWER SUPPLY VOLTAGE FOR LED DRIVER	10.8	12	13.2	POWER SUPPLY CURRENT FOR LED DRIVER	—	2	2.6	LED LIFE TIME	50K	—	—
ITEM	MIN.	TYP.	MAX.																																																														
POWER SUPPLY VOLTAGE	(3.0)	(3.3)	(3.6)																																																														
RUSH CURRENT	—	—	(1.5)																																																														
ALLOWABLE LOGIC/LCD DRIVE RIPPLE VOLTAGE	—	—	(200)																																																														
POWER SUPPLY CURRENT	—	—	(454)																																																														
POWER SUPPLY VOLTAGE FOR LED DRIVER	(10.8)	(12)	(13.2)																																																														
POWER SUPPLY CURRENT FOR LED DRIVER	—	(2)	(3)																																																														
LED LIFE TIME	(50K)	—	—																																																														
ITEM	MIN.	TYP.	MAX.																																																														
POWER SUPPLY VOLTAGE	3.0	3.3	3.6																																																														
RUSH CURRENT	—	—	1.5																																																														
ALLOWABLE LOGIC/LCD DRIVE RIPPLE VOLTAGE	—	—	200																																																														
POWER SUPPLY CURRENT	—	350	454																																																														
POWER SUPPLY VOLTAGE FOR LED DRIVER	10.8	12	13.2																																																														
POWER SUPPLY CURRENT FOR LED DRIVER	—	2	2.6																																																														
LED LIFE TIME	50K	—	—																																																														

RECORDS OF REVISION

FEB.22, 2023

DATE

REVISED
PAGE
NO.

SUMMARY

SEP.21, 2023

5

5.1.2 LVDS INTERFACE DATA MAPPING

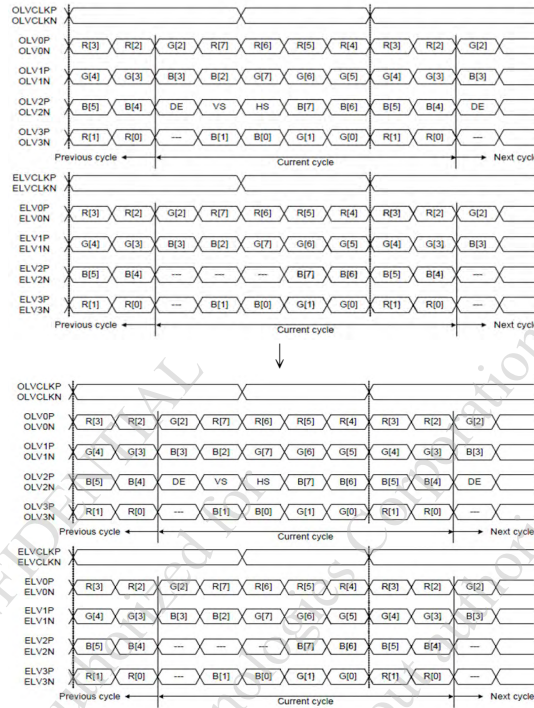

6

5.4 POWER SEQUENCE

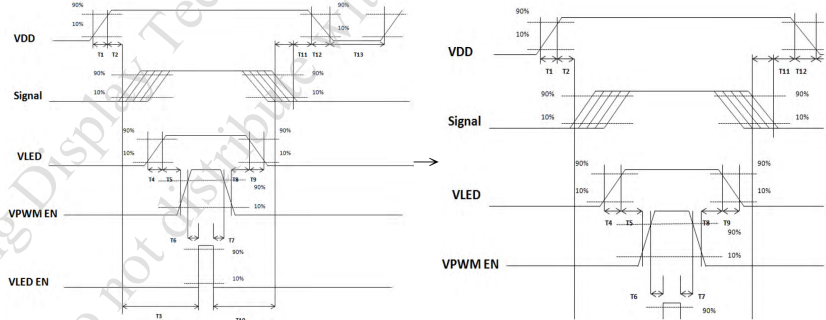

DOC . FIRST ISSUE

RECORDS OF REVISION

FEB.22, 2023

DATE	REVISED PAGE NO.	SUMMARY																																																																																																																														
SEP.21, 2023	7	<p>6.1 OPTICAL CHARACTERISTICS</p> <table border="1"> <thead> <tr> <th>ITEM</th> <th>CONDITION</th> <th>MIN.</th> <th>TYP.</th> <th>MAX.</th> </tr> </thead> <tbody> <tr> <td rowspan="4">VIEWING ANGLE</td> <td rowspan="4">CR ≥ 10</td> <td rowspan="2">θ_x=0°</td> <td>(80)</td> <td>(85)</td> <td>—</td> </tr> <tr> <td>(80)</td> <td>(85)</td> <td>—</td> </tr> <tr> <td rowspan="2">θ_y=0°</td> <td>(80)</td> <td>(85)</td> <td>—</td> </tr> <tr> <td>(80)</td> <td>(85)</td> <td>—</td> </tr> <tr> <td>CONTRAST RATIO (CENTER)</td> <td>θ_x=0°, θ_y=0°</td> <td>(700)</td> <td>(1000)</td> <td>—</td> </tr> <tr> <td>RESPONSE TIME</td> <td>θ_x=0°, θ_y=0°</td> <td>—</td> <td>(25)</td> <td>(35)</td> </tr> <tr> <td rowspan="8">COLOR CHROMATICITY (CENTER)</td> <td rowspan="8">WHITE RED GREEN BLUE</td> <td rowspan="8">θ_x=0°, θ_y=0° VDD-VSS=3.3V VBL+-VBL=-12V LED B/L=ON PWM=100%</td> <td>(0.26)</td> <td>(0.31)</td> <td>(0.36)</td> </tr> <tr> <td>(0.27)</td> <td>(0.32)</td> <td>(0.37)</td> </tr> <tr> <td>(0.59)</td> <td>(0.64)</td> <td>(0.69)</td> </tr> <tr> <td>(0.27)</td> <td>(0.32)</td> <td>(0.37)</td> </tr> <tr> <td>(0.23)</td> <td>(0.28)</td> <td>(0.33)</td> </tr> <tr> <td>(0.54)</td> <td>(0.59)</td> <td>(0.64)</td> </tr> <tr> <td>(0.08)</td> <td>(0.14)</td> <td>(0.18)</td> </tr> <tr> <td>(0.05)</td> <td>(0.10)</td> <td>(0.15)</td> </tr> <tr> <td>THE BRIGHTNESS OF MODULE (CENTER)</td> <td></td> <td>(1500)</td> <td>(1600)</td> <td>—</td> </tr> </tbody> </table> <p style="text-align: center;">↓</p> <table border="1"> <thead> <tr> <th>ITEM</th> <th>CONDITION</th> <th>MIN.</th> <th>TYP.</th> <th>MAX.</th> </tr> </thead> <tbody> <tr> <td rowspan="4">VIEWING ANGLE</td> <td rowspan="4">CR ≥ 10</td> <td rowspan="2">θ_x=0°</td> <td>80</td> <td>85</td> <td>—</td> </tr> <tr> <td>80</td> <td>85</td> <td>—</td> </tr> <tr> <td rowspan="2">θ_y=0°</td> <td>80</td> <td>85</td> <td>—</td> </tr> <tr> <td>80</td> <td>85</td> <td>—</td> </tr> <tr> <td>CONTRAST RATIO (CENTER)</td> <td>θ_x=0°, θ_y=0°</td> <td>700</td> <td>1000</td> <td>—</td> </tr> <tr> <td>RESPONSE TIME</td> <td>θ_x=0°, θ_y=0°</td> <td>—</td> <td>25</td> <td>35</td> </tr> <tr> <td rowspan="8">COLOR CHROMATICITY (CENTER)</td> <td rowspan="8">WHITE RED GREEN BLUE</td> <td rowspan="8">θ_x=0°, θ_y=0° VDD-VSS=3.30V VBL+-VBL=-12V LED B/L=ON PWM=100%</td> <td>0.27</td> <td>0.32</td> <td>0.37</td> </tr> <tr> <td>0.32</td> <td>0.37</td> <td>0.42</td> </tr> <tr> <td>0.59</td> <td>0.64</td> <td>0.69</td> </tr> <tr> <td>0.28</td> <td>0.33</td> <td>0.38</td> </tr> <tr> <td>0.25</td> <td>0.30</td> <td>0.35</td> </tr> <tr> <td>0.61</td> <td>0.66</td> <td>0.71</td> </tr> <tr> <td>0.09</td> <td>0.14</td> <td>0.19</td> </tr> <tr> <td>0.05</td> <td>0.10</td> <td>0.15</td> </tr> <tr> <td>THE BRIGHTNESS OF MODULE (CENTER)</td> <td></td> <td>1500</td> <td>1600</td> <td>—</td> </tr> </tbody> </table>	ITEM	CONDITION	MIN.	TYP.	MAX.	VIEWING ANGLE	CR ≥ 10	θ _x =0°	(80)	(85)	—	(80)	(85)	—	θ _y =0°	(80)	(85)	—	(80)	(85)	—	CONTRAST RATIO (CENTER)	θ _x =0°, θ _y =0°	(700)	(1000)	—	RESPONSE TIME	θ _x =0°, θ _y =0°	—	(25)	(35)	COLOR CHROMATICITY (CENTER)	WHITE RED GREEN BLUE	θ _x =0°, θ _y =0° VDD-VSS=3.3V VBL+-VBL=-12V LED B/L=ON PWM=100%	(0.26)	(0.31)	(0.36)	(0.27)	(0.32)	(0.37)	(0.59)	(0.64)	(0.69)	(0.27)	(0.32)	(0.37)	(0.23)	(0.28)	(0.33)	(0.54)	(0.59)	(0.64)	(0.08)	(0.14)	(0.18)	(0.05)	(0.10)	(0.15)	THE BRIGHTNESS OF MODULE (CENTER)		(1500)	(1600)	—	ITEM	CONDITION	MIN.	TYP.	MAX.	VIEWING ANGLE	CR ≥ 10	θ _x =0°	80	85	—	80	85	—	θ _y =0°	80	85	—	80	85	—	CONTRAST RATIO (CENTER)	θ _x =0°, θ _y =0°	700	1000	—	RESPONSE TIME	θ _x =0°, θ _y =0°	—	25	35	COLOR CHROMATICITY (CENTER)	WHITE RED GREEN BLUE	θ _x =0°, θ _y =0° VDD-VSS=3.30V VBL+-VBL=-12V LED B/L=ON PWM=100%	0.27	0.32	0.37	0.32	0.37	0.42	0.59	0.64	0.69	0.28	0.33	0.38	0.25	0.30	0.35	0.61	0.66	0.71	0.09	0.14	0.19	0.05	0.10	0.15	THE BRIGHTNESS OF MODULE (CENTER)		1500	1600	—
ITEM	CONDITION	MIN.	TYP.	MAX.																																																																																																																												
VIEWING ANGLE	CR ≥ 10	θ _x =0°	(80)	(85)	—																																																																																																																											
			(80)	(85)	—																																																																																																																											
		θ _y =0°	(80)	(85)	—																																																																																																																											
			(80)	(85)	—																																																																																																																											
CONTRAST RATIO (CENTER)	θ _x =0°, θ _y =0°	(700)	(1000)	—																																																																																																																												
RESPONSE TIME	θ _x =0°, θ _y =0°	—	(25)	(35)																																																																																																																												
COLOR CHROMATICITY (CENTER)	WHITE RED GREEN BLUE	θ _x =0°, θ _y =0° VDD-VSS=3.3V VBL+-VBL=-12V LED B/L=ON PWM=100%	(0.26)	(0.31)	(0.36)																																																																																																																											
			(0.27)	(0.32)	(0.37)																																																																																																																											
			(0.59)	(0.64)	(0.69)																																																																																																																											
			(0.27)	(0.32)	(0.37)																																																																																																																											
			(0.23)	(0.28)	(0.33)																																																																																																																											
			(0.54)	(0.59)	(0.64)																																																																																																																											
			(0.08)	(0.14)	(0.18)																																																																																																																											
			(0.05)	(0.10)	(0.15)																																																																																																																											
THE BRIGHTNESS OF MODULE (CENTER)		(1500)	(1600)	—																																																																																																																												
ITEM	CONDITION	MIN.	TYP.	MAX.																																																																																																																												
VIEWING ANGLE	CR ≥ 10	θ _x =0°	80	85	—																																																																																																																											
			80	85	—																																																																																																																											
		θ _y =0°	80	85	—																																																																																																																											
			80	85	—																																																																																																																											
CONTRAST RATIO (CENTER)	θ _x =0°, θ _y =0°	700	1000	—																																																																																																																												
RESPONSE TIME	θ _x =0°, θ _y =0°	—	25	35																																																																																																																												
COLOR CHROMATICITY (CENTER)	WHITE RED GREEN BLUE	θ _x =0°, θ _y =0° VDD-VSS=3.30V VBL+-VBL=-12V LED B/L=ON PWM=100%	0.27	0.32	0.37																																																																																																																											
			0.32	0.37	0.42																																																																																																																											
			0.59	0.64	0.69																																																																																																																											
			0.28	0.33	0.38																																																																																																																											
			0.25	0.30	0.35																																																																																																																											
			0.61	0.66	0.71																																																																																																																											
			0.09	0.14	0.19																																																																																																																											
			0.05	0.10	0.15																																																																																																																											
THE BRIGHTNESS OF MODULE (CENTER)		1500	1600	—																																																																																																																												
	20	<p>13.1 STANDARD SPECIFICATIONS FOR RELIABILITY OF LCD MODULE</p> <p>NOTE(2): WHEN THE LCD MODULE IS OPERATED AT AMBIENT TEMPERATURE 80°C, THE PWM DUTY CYCLE OF THE LED BACKLIGHT SHOULD BE ADJUSTED TO BE LESS THAN TBD.</p> <p>IF THE MODULE IS OPERATED AT A HIGHER DUTY CYCLE THAN TBD, THEN THERE IS A POSSIBILITY OF DISTORTION AND IRREGULARITY OF THE PICTURE DUE TO LIQUID CRYSTAL BEHAVIOR.→</p> <p>WHEN THE LCD MODULE IS OPERATED AT AMBIENT TEMPERATURE 60°C, THE PWM DUTY CYCLE OF THE LED BACKLIGHT SHOULD BE ADJUSTED TO BE LESS THAN 50%.</p> <p>IF THE MODULE IS OPERATED AT A HIGHER DUTY CYCLE THAN 50%, THEN THERE IS A POSSIBILITY OF DISTORTION AND IRREGULARITY OF THE PICTURE DUE TO LIQUID CRYSTAL BEHAVIOR.</p>																																																																																																																														

TABLE OF CONTENTS

NO.	ITEM	PAGE
1.	GENERAL SPECIFICATIONS -----	1
2.	MECHANICAL SPECIFICATIONS -----	1
3.	ABSOLUTE MAXIMUM RATINGS -----	2
4.	ELECTRICAL CHARACTERISTICS -----	3
5.	TIMING CHARACTERISTICS -----	4 ~ 6
6.	OPTICAL CHARACTERISTICS -----	7, 8
7.	OUTLINE DIMENSIONS -----	9
8.	BLOCK DIAGRAM -----	10
9.	DETAIL DRAWING OF DOT MATRIX -----	11
10.	INTERFACE SIGNALS -----	12
11.	POWER SUPPLY -----	13
12.	INSPECTION CRITERIA -----	14 ~ 19
13.	RELIABILITY TEST -----	20
14.	CAUTION -----	21, 22

CONFIDENTIAL
Authorized for Emerging Display Technologies Corporation Only.
Do not distribute without authorization.

1. GENERAL SPECIFICATIONS

1.1 DATA SHEETS FOR LCD MODULE CONTROLLER/DRIVER

PLEASE REFER TO :

HX-8255B

1.2 MATERIAL SAFETY DESCRIPTION

ASSEMBLIES SHALL COMPLY WITH EUROPEAN ROHS REQUIREMENTS, INCLUDING PROHIBITED MATERIALS/COMPONENTS CONTAINING LEAD, MERCURY, CADMIUM, HEXAVALENT CHROMIUM, POLYBROMINATED BIPHENYLS (PBB) AND POLYBROMINATED DIPHENYL ETHERS (PBDE), BIS(2-ETHYLHEXYL) PHTHALATE (DEHP), BUTYL BENZYL PHTHALATE (BBP), DIBUTYL PHTHALATE (DBP), DIISOBUTYL PHTHALATE (DIBP).

2. MECHANICAL SPECIFICATIONS

(1) DISPLAY SIZE	-----	15.6 inch
(2) NUMBER OF DOTS	-----	1920(RGB)W * 1080H DOTS
(3) MODULE SIZE	-----	363.8W * 215.9H * 13D(MAX.) mm
(4) VIEWING AREA	-----	347.16W * 196.59H mm
(5) ACTIVE AREA	-----	344.16W * 193.59H mm
(6) DOT SIZE	-----	0.05975W * 0.17925H mm
(7) PIXEL SIZE	-----	0.17925W * 0.17925H mm
(8) LCD TYPE	-----	TFT, IPS, TRANSMISSIVE, NORMALLY BLACK, AG-3H
(9) COLOR	-----	16.7M
(10) VIEWING DIRECTION	-----	SUPER WIDE VIEW
(11) BACK LIGHT	-----	LED , COLOR : WHITE
(12) INTERFACE MODE	-----	LVDS(VESA)
(13) WEIGHT	-----	755g

3. ABSOLUTE MAXIMUM RATINGS

3.1 ELECTRICAL ABSOLUTE MAXIMUM RATINGS

ITEM	SYMBOL	MIN.	MAX.	UNIT	REMARK
POWER SUPPLY VOLTAGE	VDD-VSS	-0.3	4.0	V	
POWER SUPPLY VOLTAGE FOR LED DRIVER	VBL+-VSS	-0.3	27	V	

3.2 ENVIRONMENTAL ABSOLUTE MAXIMUM RATINGS

ITEM	OPERATING		STORAGE		REMARK
	MIN.	MAX.	MIN.	MAX.	
AMBIENT TEMPERATURE	-30°C	85°C	-30°C	85°C	NOTE (1), (2), (3), (4)
HUMIDITY	NOTE (3)		NOTE (3)		WITHOUT CONDENSATION
VIBRATION	—	2.45 m/s ² (0.25 G)	—	11.76m/s ² (1.2 G)	10~100 Hz XYZ DIRECTIONS 1 HR EACH
SHOCK	—	29.4 m/s ² (3 G)	—	490.0 m/s ² (50 G)	10 ms XYZ DIRECTIONS 1 TIME EACH
CORROSIVE GAS	NOT ACCEPTABLE		NOT ACCEPTABLE		

NOTE (1) : THE ABSOLUTE MAXIMUM RATINGS OF THIS PRODUCT SHOULD NOT BE EXCEEDED AT ANY TIME. IF THESE RATINGS ARE EXCEEDED, THE PRODUCT'S PERFORMANCE IS NOT GUARANTEED AND THE PRODUCT MAY EXPERIENCE PERMANENT DAMAGE.

NOTE (2) : BACKGROUND COLOR CHANGES SLIGHTLY DEPENDING ON AMBIENT TEMPERATURE THIS PHENOMENON IS REVERSIBLE.

NOTE (3) : Ta ≤ 40°C : 90%RH MAX. (96HRS MAX).

Ta > 40°C : ABSOLUTE HUMIDITY MUST BE LOWER THAN THE HUMIDITY OF 90%RH AT 40°C (96HRS MAX).

NOTE (4) : WHEN THE LCD MODULE IS OPERATED AT AMBIENT TEMPERATURE 60°C, THE PWM DUTY CYCLE OF THE LED BACKLIGHT SHOULD BE ADJUSTED TO BE LESS THAN 50%. IF THE MODULE IS OPERATED AT A HIGHER DUTY CYCLE THAN 50%, THEN THERE IS A POSSIBILITY OF DISTORTION AND IRREGULARITY OF THE PICTURE DUE TO LIQUID CRYSTAL BEHAVIOR.

4. ELECTRICAL CHARACTERISTICS

4.1 ELECTRICAL CHARACTERISTICS

Ta = 25 °C

ITEM	SYMBOL	CONDITION	MIN.	TYP.	MAX.	UNIT	REMARK
POWER SUPPLY VOLTAGE	VDD-VSS	—	3.0	3.3	3.6	V	
RUSH CURRENT	I _{Rush}	—	—	—	1.5	A	NOTE (4)
ALLOWABLE LOGIC/LCD DRIVE RIPPLE VOLTAGE	V _{VDD-RP}	—	—	—	200	mV	NOTE (3)
POWER SUPPLY CURRENT	IDD	VDD-VSS = 3.3V	—	350	454	mA	NOTE (1)
POWER SUPPLY VOLTAGE FOR LED DRIVER	VBL+-VBL-	—	10.8	12	13.2	V	NOTE (2)
POWER SUPPLY VOLTAGE FOR LED DRIVER	BL_PWM	V _{IH}	1.6	—	—	V	
		V _{IL}	—	—	0.8	V	
	BL_EN	V _{IH}	1.6	—	—	V	
		V _{IL}	—	—	0.8	V	
POWER SUPPLY CURRENT FOR LED DRIVER	IBL+	VBL+-VBL- = 12V LED B/L=ON PWM=100%	—	2	2.6	A	
LED LIFE TIME	—	IF=60mA (PER LED)	50K	—	—	HRS	NOTE (5) NOTE (6)

NOTE (1) : THE DISPLAY PATTERN IS ALL “WHITE”.

NOTE (2) : INTERNAL CIRCUIT DIAGRAM OF BACKLIGHT

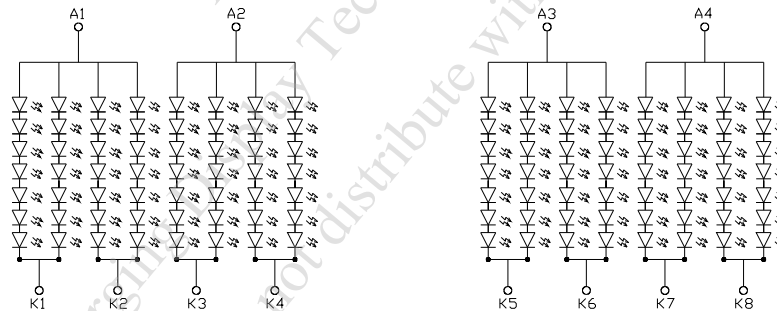

NOTE (3) : THE SPECIFIED V_{CC} CURRENT AND POWER CONSUMPTION ARE MEASURED UNDER THE V_{DD} = 3.3 V, F_V = 60 Hz CONDITION AND WHITE PATTERN.

NOTE (4) : THE FIGURES BELOW IS THE MEASURING CONDITION OF V_{DD}. RUSH CURRENT CAN BE MEASURED WHEN T_{RUSH} IS 0.5 ms.

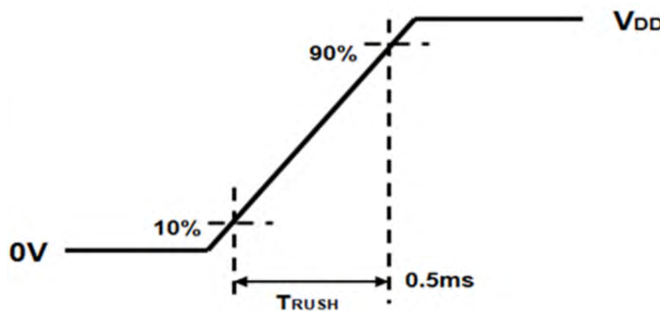

NOTE (5) : CONDITIONS; Ta=25 °C, CONTINUOUS LIGHTING

NOTE (6) : DEFINITIONS OF LIFE TIME :

5. TIMING CHARACTERISTICS

5.1 SIGNAL ELECTRICAL CHARACTERISTICS

5.1.1 SIGNAL ELECTRICAL CHARACTERISTICS FOR LVDS RECEIVER
THE BUILT-IN LVDS RECEIVER IS COMPATIBLE WITH (ANSI/TIA/TIA-644)
STANDARD.

LVDS RECEIVER ELECTRICAL CHARACTERISTICS

ITEM	SYMBOL	MIN.	TYP.	MAX.	UNIT	CONDITIONS
DIFFERENTIAL INPUT HIGH THRESHOLD	V_{th}	—	—	(+100)	mV	$V_{CM} = 1.2V$
DIFFERENTIAL INPUT LOW THRESHOLD	V_{tl}	(-100)	—	—	mV	$V_{CM} = 1.2V$
MAGNITUDE DIFFERENTIAL INPUT VOLTAGE	$ V_{ID} $	(150)	—	(600)	mV	
COMMON MODE VOLTAGE	V_{CM}	(0.7)	—	(1.6)	V	

NOTE (1) : INPUT SIGNALS SHALL BE LOW OR HI- RESISTANCE STATE WHEN VDD IS OFF.

NOTE (2) : ALL ELECTRICAL CHARACTERISTICS FOR LVDS SIGNAL ARE DEFINED AND SHALL BE MEASURED AT THE INTERFACE CONNECTOR OF LCD.

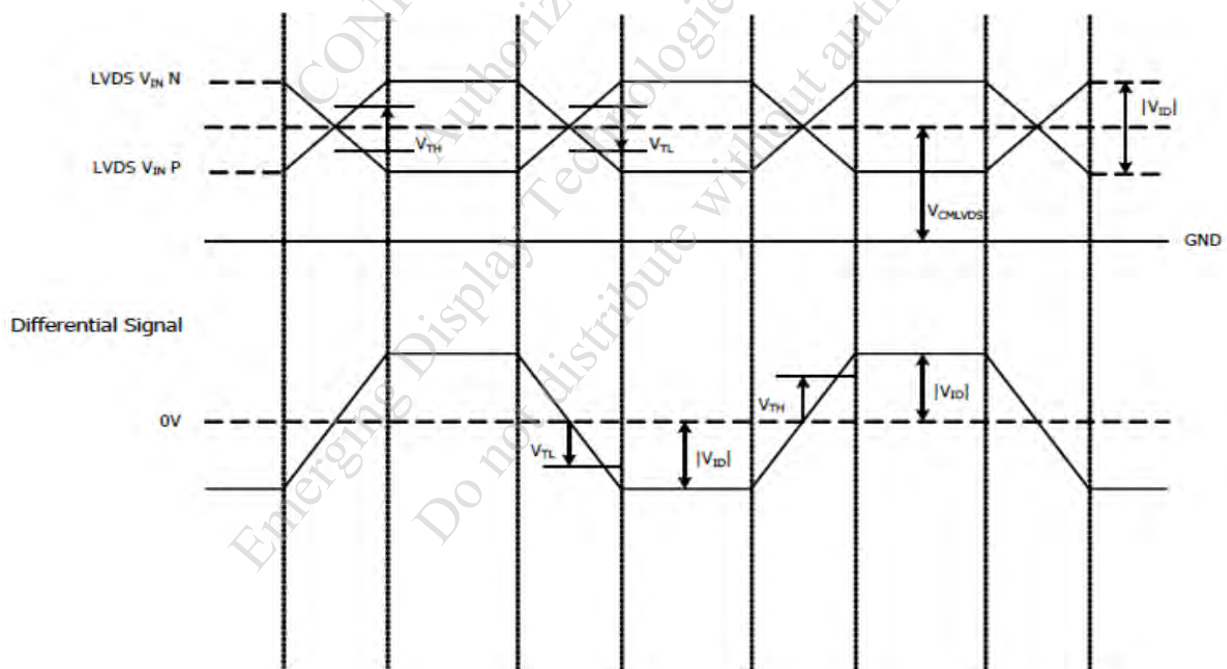

VOLTAGE DEFINITIONS

LVDS AC ELECTRICAL CHARACTERISTICS

ITEM	SYMBOL	MIN.	TYP.	MAX.	UNIT	CONDITIONS
CLOCK PERIOD	TLVCP	—	(T)	—	ns	
CLOCK HIGH TIME	TLVCH	—	(4T/7)	—	ns	
CLOCK LOW TIME	TLVCL	—	(3T/7)	—	ns	

NOTE : $T = 1/F_{clk}$

5.1.2 LVDS INTERFACE DATA MAPPING

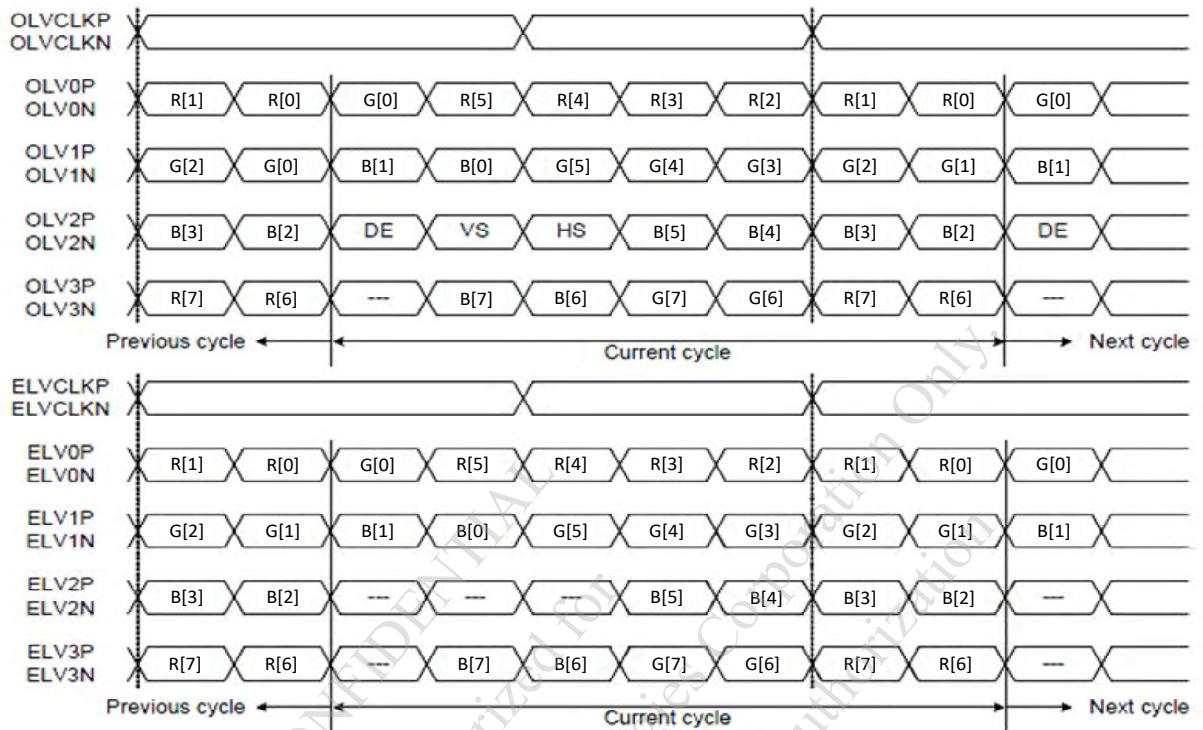

DATA MAPPING

5.2 LVDS RECEIVER INTERNAL CIRCUIT

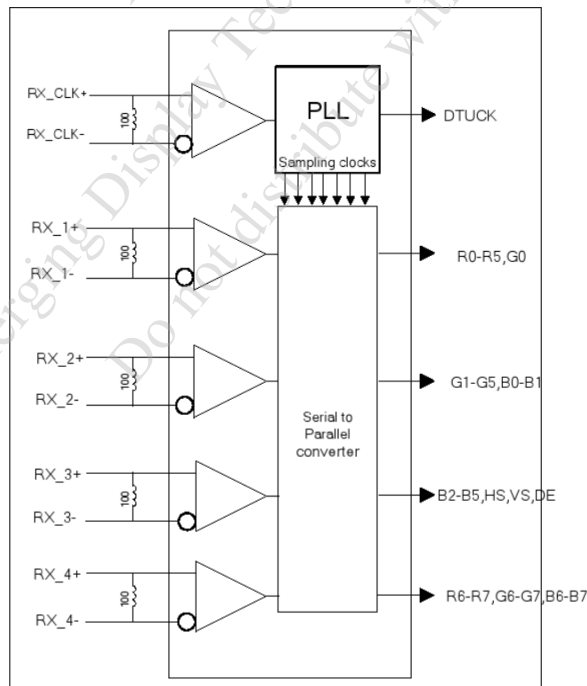

LVDS RECEIVER INTERNAL CIRCUIT

5.3 LVDS INTERFACE TIMING

ITEM	SYMBOL	MIN.	TYP.	MAX.	UNIT	REMARK
LVDS CLOCK FREQUENCY	Fclk	(69.5)	(70.5)	(73)	Mhz	
V TOTAL TIME	VT	(1104)	(1116)	(1080+A)	Clocks	
V ACTIVE TIME	VA	1080			—	
H TOTAL TIME	HT	(1050)	(1052)	(1920+B)	Lines	
H ACTIVE TIME	HA	1920			—	
FRAME RATE	FV	—	(60)	—	Hz	

NOTE (1) : SSC CAN ONLY BE DRIVEN TO 2%

NOTE (2) : THE MAXIMUM CLOCK FREQUENCY= $[(1920+B)*(1080+A)*60]<73\text{MHz}$

5.4 POWER SEQUENCE

INTERFACE SIGNALS ARE ALSO SHOWN IN THE CHART. SIGNALS FROM ANY SYSTEM SHALL BE HI- RESISTANCE STATE OR LOW LEVEL WHEN VDD VOLTAGE IS OFF.

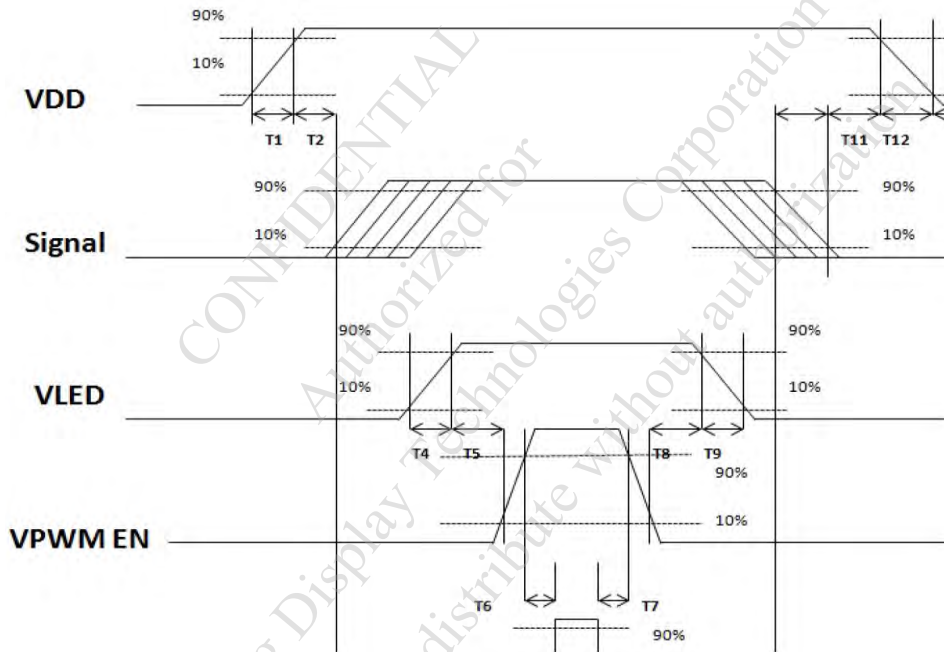

POWER SEQUENCE

POWER SEQUENCING REQUIREMENTS

ITEM	MIN.	TYP.	MAX.	UNIT	REMARK
T1	(0.5)	—	(10)	ms	
T2	(30)	(40)	(50)	ms	
T3	(200)	—	—	ms	
T4	(0.5)	—	(10)	ms	
T5	(10)	—	—	ms	
T6	(10)	—	—	ms	
T7	(0)	—	—	ms	
T8	(10)	—	—	ms	
T9	—	—	(10)	ms	
T10	(110)	—	—	ms	
T11	(0)	(16)	(50)	ms	
T12	—	—	(10)	ms	
T13	(1000)	—	—	ms	

6. OPTICAL CHARACTERISTICS

6.1 OPTICAL CHARACTERISTICS

Ta = 25 ± 2 °C

ITEM	SYMBOL	CONDITION	MIN.	TYP.	MAX.	UNIT	REMARK	
VIEWING ANGLE	θ_{y+}	CR ≥ 10	$\theta_x=0^\circ$	80	85	—	deg	NOTE (2) NOTE (3)
	θ_{y-}			80	85	—	deg	
	θ_{x+}		$\theta_y=0^\circ$	80	85	—	deg	
	θ_{x-}			80	85	—	deg	
CONTRAST RATIO (CENTER)	CR	$\theta_x=0^\circ, \theta_y=0^\circ$	700	1000	—	—	NOTE (3)	
RESPONSE TIME	TR+TF	$\theta_x=0^\circ, \theta_y=0^\circ$	—	25	35	msec	NOTE (4)	
COLOR CHROMATICITY (CENTER)	WHITE	Wx	$\theta_x=0^\circ, \theta_y=0^\circ$ VDD-VSS=3.30V VBL+ -VBL- =12V LED B/L=ON PWM=100%	0.27	0.32	0.37	—	NOTE (5)
		Wy		0.32	0.37	0.42		
	RED	Rx		0.59	0.64	0.69	—	
		Ry		0.28	0.33	0.38		
	GREEN	Gx		0.25	0.30	0.35	—	
		Gy		0.61	0.66	0.71		
	BLUE	Bx		0.09	0.14	0.19	—	
		By		0.05	0.10	0.15		
THE BRIGHTNESS OF MODULE (CENTER)	B		1500	1600	—	cd/m ²	NOTE (6)	
THE UNIFORMITY OF MODULE	—		70	—	—	%	NOTE (7)	

NOTE (1) : TEST CONDITION :

AFTER STABILIZING AND LEAVING THE PANEL ALONE AT A GIVEN TEMPERATURE FOR 30 MINUTES. MEASUREMENT SHOULD BE EXECUTED IN A STABLE, WINDLESS, AND DARK ROOM.

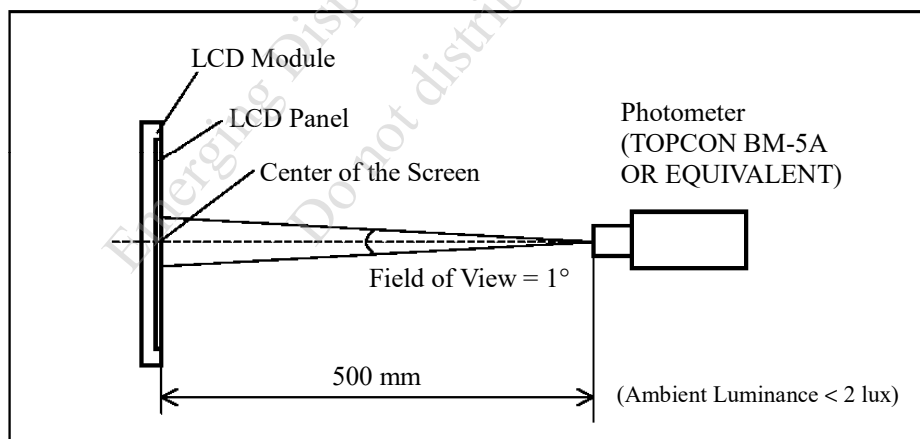

NOTE (2) : DEFINITION OF VIEWING ANGLE :

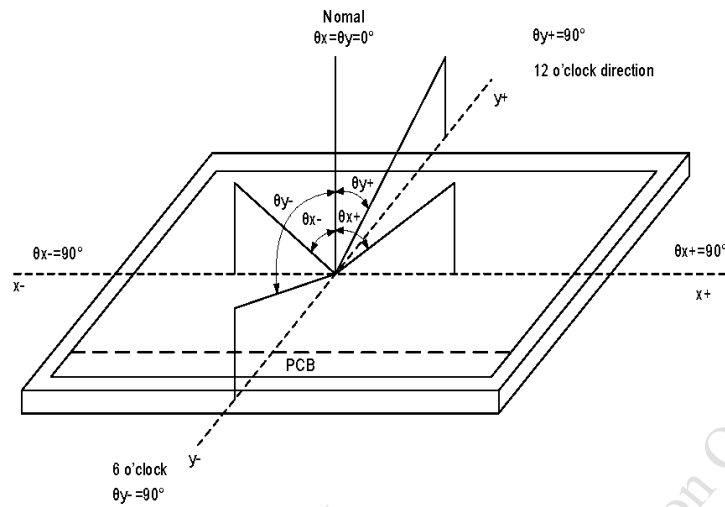

NOTE (3) : DEFINITION OF CONTRAST RATIO (CR) :
MEASURED AT THE CENTER POINT OF MODULE

$$\text{CONTRAST RATIO (CR)} = \frac{\text{BRIGHTNESS MEASURED WHEN LCD IS AT "WHITE STATE"}}{\text{BRIGHTNESS MEASURED WHEN LCD IS AT "BLACK STATE"}}$$

NOTE (4) : DEFINITION OF RESPONSE TIME : T_R AND T_F
THE FIGURE BELOW IS THE OUTPUT SIGNAL OF THE PHOTO DETECTOR.

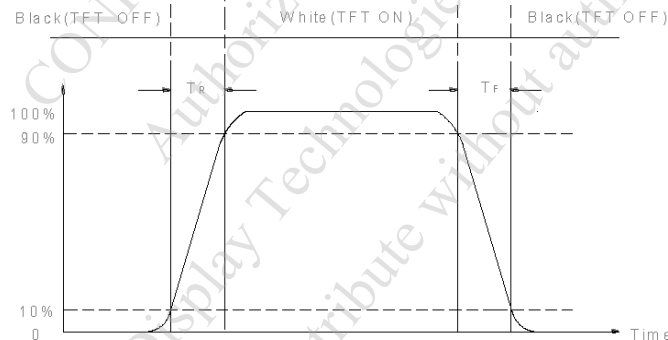

NOTE (5) : DEFINITION OF COLOR CHROMATICITY

(a) 100% RGB PIXEL DATA TRANSMISSION WHEN ALL THE INPUT TERMINALS OF MODULE ARE ELECTRICALLY POWERED ON.

(b) MEASURED AT THE CENTER POINT OF MODULE

NOTE (6) : MEASURED THE BRIGHTNESS OF WHITE STATE AT CENTER POINT.

NOTE (7) : (a) DEFINITION OF BRIGHTNESS UNIFORMITY

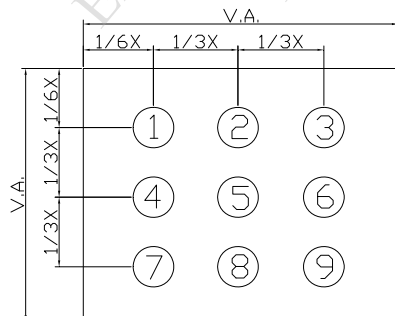



UNIT : mm

(b) THE BRIGHTNESS UNIFORMITY CALCULATING METHOD

$$\text{UNIFORMITY} = \frac{\text{MINIMUM BRIGHTNESS}}{\text{MAXIMUM BRIGHTNESS}} * 100\%$$

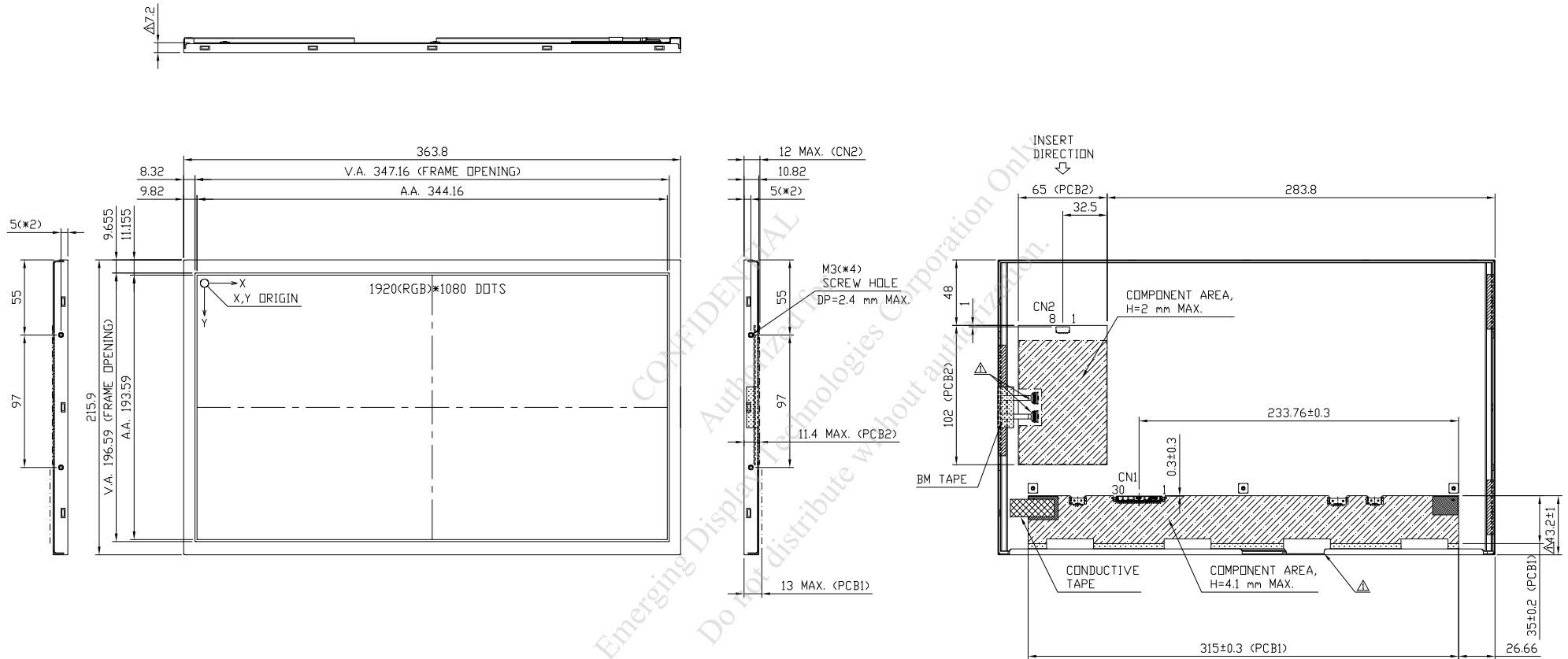
7. OUTLINE DIMENSIONS



UNIT : mm
 SCALE : NTS
 THIRD ANGLE PROJECTION
 NOT SPECIFIED TOLERANCE IS ± 0.5
 MARK△MODIFY (NUMBER NOTE MODIFY VERSION)
 NOTE :
 1.CN1 : STM MSBKT2407P30HB OR EQUIVALENT.
 2.CN2 : JST SM08B-SRSS-TB OR EQUIVALENT.

8. BLOCK DIAGRAM

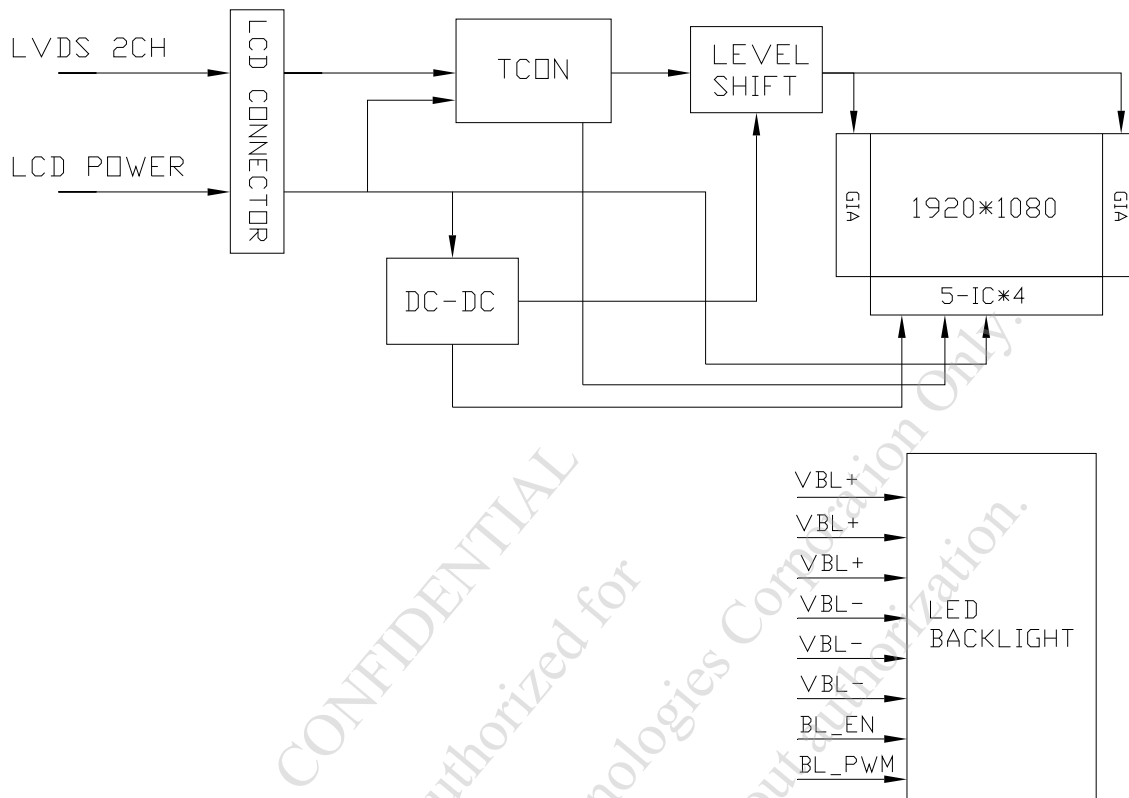

CONFIDENTIAL
Authorized for
Emerging Display Technologies Corporation Only.
Do not distribute without authorization.

9. DETAIL DRAWING OF DOT MATRIX

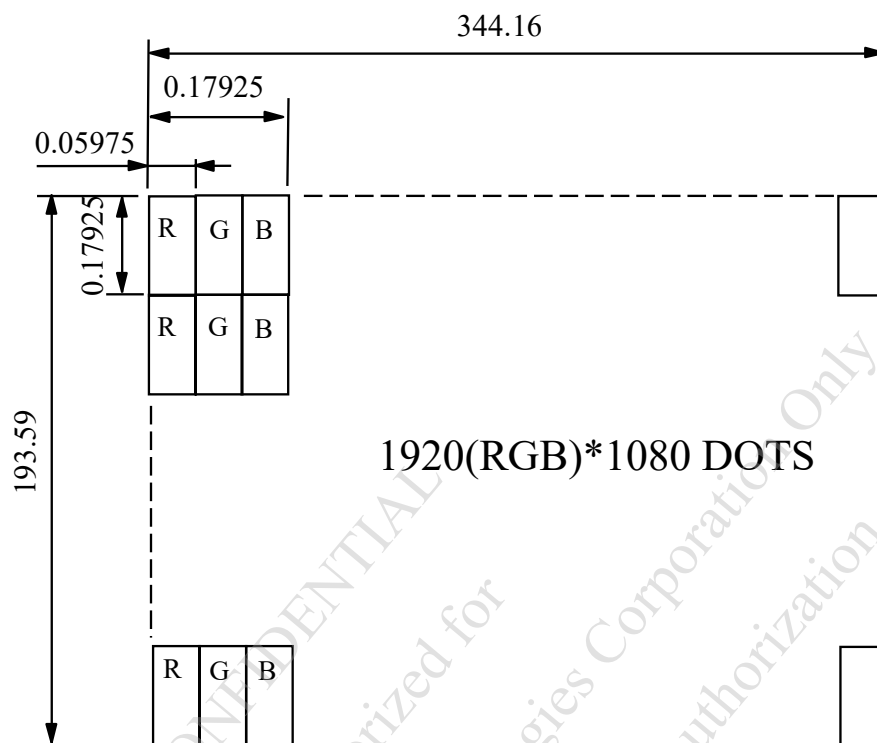

UNIT : mm
SCALE : NTS
NOT SPECIFIED TOLERANCE IS ± 0.1
DOTS MATRIX TOLERANCE IS ± 0.01

CONFIDENTIAL
Authorized for Emerging Display Technologies Corporation Only
Do not distribute without authorization

10. INTERFACE SIGNALS

10.1 CN1

PIN NO.	SYMBOL	FUNCTION	REMARKS
1	RxO0-	NEGATIVE LVDS DIFFERENTIAL DATA INPUT (ODD DATA)	
2	RxO0+	POSITIVE LVDS DIFFERENTIAL DATA INPUT (ODD DATA)	
3	RxO1-	NEGATIVE LVDS DIFFERENTIAL DATA INPUT (ODD DATA)	
4	RxO1+	POSITIVE LVDS DIFFERENTIAL DATA INPUT (ODD DATA)	
5	RxO2-	NEGATIVE LVDS DIFFERENTIAL DATA INPUT (ODD DATA)	
6	RxO2+	POSITIVE LVDS DIFFERENTIAL DATA INPUT (ODD DATA)	
7	VSS	GROUND	
8	RxOCLK-	NEGATIVE LVDS DIFFERENTIAL CLOCK INPUT (ODD CLOCK)	
9	RxOCLK+	POSITIVE LVDS DIFFERENTIAL CLOCK INPUT (ODD CLOCK)	
10	RxO3-	NEGATIVE LVDS DIFFERENTIAL DATA INPUT (ODD DATA)	
11	RxO3+	POSITIVE LVDS DIFFERENTIAL DATA INPUT (ODD DATA)	
12	RxE0-	NEGATIVE LVDS DIFFERENTIAL DATA INPUT (EVEN DATA)	
13	RxE0+	POSITIVE LVDS DIFFERENTIAL DATA INPUT (EVEN DATA)	
14	VSS	GROUND	
15	RxE1-	NEGATIVE LVDS DIFFERENTIAL DATA INPUT (EVEN DATA)	
16	RxE1+	POSITIVE LVDS DIFFERENTIAL DATA INPUT (EVEN DATA)	
17	VSS	GROUND	
18	RxE2-	NEGATIVE LVDS DIFFERENTIAL DATA INPUT (EVEN DATA)	
19	RxE2+	POSITIVE LVDS DIFFERENTIAL DATA INPUT (EVEN DATA)	
20	RxECLK-	NEGATIVE LVDS DIFFERENTIAL CLOCK INPUT (EVEN DATA)	
21	RxECLK+	POSITIVE LVDS DIFFERENTIAL CLOCK INPUT (EVEN DATA)	
22	RxE3-	NEGATIVE LVDS DIFFERENTIAL DATA INPUT (EVEN DATA)	
23	RxE3+	POSITIVE LVDS DIFFERENTIAL DATA INPUT (EVEN DATA)	
24	VSS	GROUND	
25	BIST	LCD PANEL SELF TEST ENABLE(3.3V TYP) FOR EDT USE, WHEN IT IS NOT USED, CONNECTING TO GND OR FLOATING IS RECOMMENDED	
26	SDA	I2C-COMPATIBLE SERIAL-DATA INPUT FOR EDT USE , FLOATING IS RECOMMENDED IN THE COSTUMER	
27	SCL	I2C-COMPATIBLE SERIAL-CLOCK INPUT FOR EDT USE , FLOATING IS RECOMMENDED IN THE COSTUMER	
28	VDD	POWER SUPPLY INPUT VOLTAGE(3.3V)	
29	VDD	POWER SUPPLY INPUT VOLTAGE(3.3V)	
30	VDD	POWER SUPPLY INPUT VOLTAGE(3.3V)	

10.2 CN2

PIN NO.	SYMBOL	FUNCTION
1	VBL+	POWER SUPPLY VOLTAGE FOR LED DRIVER(+)
2	VBL+	POWER SUPPLY VOLTAGE FOR LED DRIVER(+)
3	VBL+	POWER SUPPLY VOLTAGE FOR LED DRIVER(+)
4	VBL-	POWER SUPPLY VOLTAGE FOR LED DRIVER(-)
5	VBL-	POWER SUPPLY VOLTAGE FOR LED DRIVER(-)
6	VBL-	POWER SUPPLY VOLTAGE FOR LED DRIVER(-)
7	BL EN	BACKLIGHT LED ON/OFF CONTROL
8	BL PWM	BACKLIGHT LED BRIGHTNESS CONTROL

11. POWER SUPPLY

11.1 POWER SUPPLY FOR LCM

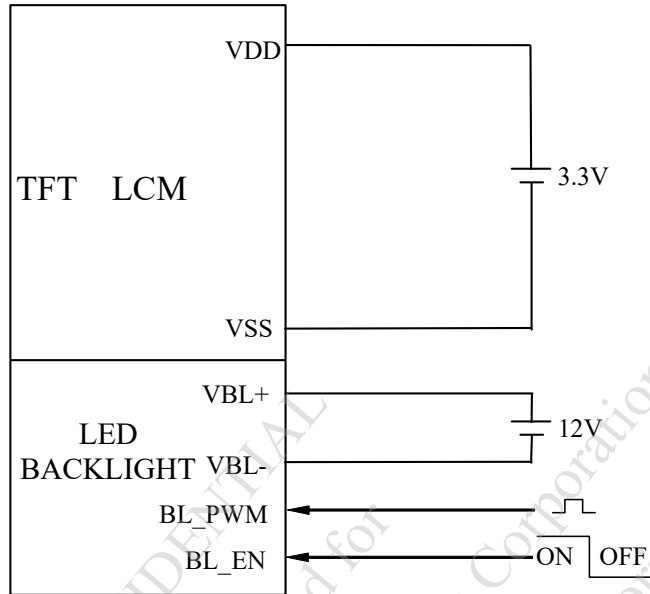

NOTE (1) : ADJUST THE PWM SIGNAL IN ORDER TO CONTROL LED BACKLIGHT'S BRIGHTNESS. THE HIGHER THE DUTY CYCLE, THE HIGHER THE BRIGHTNESS

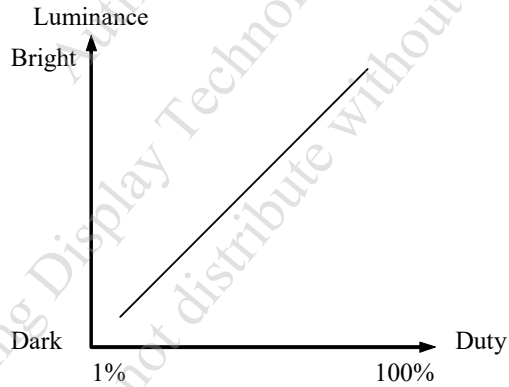

NOTE (2) : PWM SIGNAL OPERATION FREQUENCY IS 100~2000 Hz AND DIMMING DUTY.

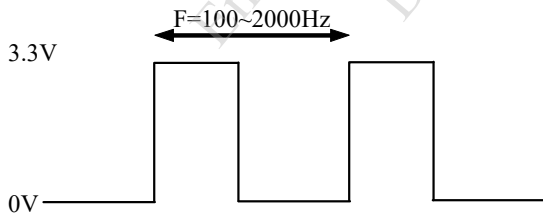

PWM Dimming Frequency[Hz]	Dimming Duty	
	Min[%]	Max[%]
100 <math>< F_{DIM} < 200</math>	0.1	100
200 <math>< F_{DIM} < 500</math>	0.4	100
500 <math>< F_{DIM} < 1K</math>	0.8	100
1K <math>< F_{DIM} < 2K</math>	1.5	100

12. INSPECTION CRITERIA

12.1 APPLICATION

THIS INSPECTION STANDARD IS TO BE APPLIED TO THE LCD MODULE DELIVERED FROM EMERGING DISPLAY TECHNOLOGIES CORP.(E.D.T) TO CUSTOMERS

12.2 INSPECTION CONDITIONS

12.2.1 (1)OBSERVATION DISTANCE : 45 ± 5 cm

(2)VIEWING ANGLE : $\pm 45^\circ$

$\pm 45^\circ$ (FOR SECTION WITHIN VIEWING AREA), REFER TO FIG.A
 90° (FOR SECTION OUTSIDE OF VIEWING AREA), REF TO FIG.B
 PERPENDICULAR TO MODULE SURFACE

VIEWING ANGLE SHOULD BE SMALLER THAN 45°

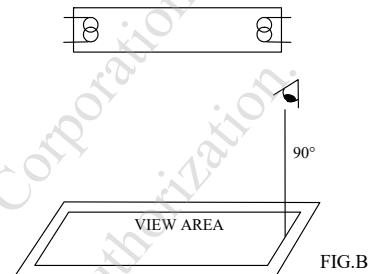
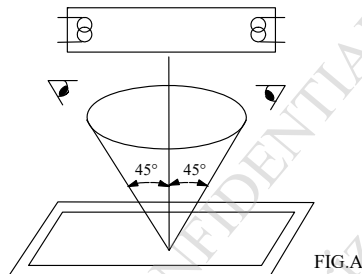

THE INSPECTION CRITERIA IS ACCORDING TO LINE OF SIGHT. INSPECTION SHALL BE MADE WITHIN THE HALF SECTION OF THE VIEWING CONE GENERATED BY LINE SEGMENT OF 45° WITH RESPECT TO THE VERTICAL AXIS FROM CENTER VERTEX OF LCD, THE FLUORESCENT LAMP AND THE CONE AXIS MUST BE PERPENDICULAR TO THE LCD SURFACE.

IF THE DEFECTS ARE OUTSIDE OF VIEWING AREA, IT SHALL BE INSPECTED BY 90° WITH RESPECT TO THE VERTICAL AXIS FROM EDGE OF VIEWING AREA.

12.2.2 ENVIRONMENT CONDITIONS :

AMBIENT TEMPERATURE		$20 \pm 5^\circ\text{C}$
AMBIENT HUMIDITY		$55 \pm 20\% \text{RH}$
AMBIENT ILLUMINATION	COSMETIC INSPECTION	600~800 lux
	FUNCTIONAL INSPECTION	300~500 lux
INSPECTION TIME		15 secs

12.2.3 INSPECTION LOT

QUANTITY PER DELIVERY LOT FOR EACH MODEL

12.2.4 INSPECTION METHOD

A SAMPLING INSPECTION SHALL BE MADE ACCORDING TO THE FOLLOWING PROVISIONS TO JUDGE THE ACCEPTABILITY

(a)APPLICABLE STANDARD :





ANSI/ ASQ Z1.4 NORMAL INSPECTION LEVEL II

(b)AQL : MAJOR DEFECT : AQL 0.65

MINOR DEFECT : AQL 1.5

12.3 DEFECTS CLASSIFICATION

TYPE OF DEFECT	INSPECTION ITEM	DEFECT FEATURE	AQL
MAJOR DEFECT	DISPLAY ON	<ul style="list-style-type: none"> • DEFECT TO MISS SPECIFIED DISPLAY FUNCTION, FOR ALL AND SPECIFIED DOTS EX: DISCONNECTION, SHORT CIRCUIT ETC 	0.65
	BACKLIGHT	<ul style="list-style-type: none"> • NO LIGHT • FLICKERING AND OTHER ABNORMAL ILLUMINATION 	
	DIMENSIONS	<ul style="list-style-type: none"> • SUBJECT TO INDIVIDUAL ACCEPTANCE SPECIFICATIONS 	
MINOR DEFECT	DISPLAY ZONE (VIEWING AREA)	<ul style="list-style-type: none"> • BLACK/WHITE SPOT / CIRCULAR TYPE • BUBBLES ON POLARIZER • NEWTON RING • BLACK/WHITE LINE / LINEAR TYPE • SCRATCH • CONTAMINATION • UNEVEN COLOR SPREAD 	1.5
	BEZEL ZONE	<ul style="list-style-type: none"> • STAINS • SCRATCHES • FOREIGN MATTER 	
	SOLDERING	<ul style="list-style-type: none"> • INSUFFICIENT SOLDER • SOLDERED IN INCORRECT POSITION • CONVEX SOLDERING SPOT • SOLDER BALLS • SOLDER SCRAPS 	
	DISPLAY ON (ALL ON)	<ul style="list-style-type: none"> • LIGHT LINE 	

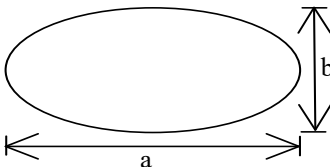
NO.	ITEM	CRITERIA																																								
1	DISPLAY ON INSPECTION	(1) INCORRECT PATTERN (2) MISSING SEGMENT (3) DIM SEGMENT (4) OPERATING VOLTAGE BEYOND SPEC																																								
2	OVERALL DIMENSIONS	OVERALL DIMENSION BEYOND SPEC																																								
3	DOT DEFECT	<p>(1) INSPECTION PATTERN: FULL WHITE, FULL BLACK, RED, GREEN AND BLUE SCREENS.</p> <p>(2)</p> <table border="1"> <thead> <tr> <th colspan="2">ITEM</th> <th>STANDARD</th> </tr> <tr> <th colspan="2"></th> <th>Z</th> </tr> </thead> <tbody> <tr> <td rowspan="3">BRIGHT DOT</td> <td>RANDOM</td> <td>N≤2</td> </tr> <tr> <td>2 DOTS ADJACENT (PAIR)</td> <td>N=0</td> </tr> <tr> <td>3 DOTS ADJACENT OR MORE</td> <td>N=0</td> </tr> <tr> <td rowspan="3">DARK DOT</td> <td>RANDOM</td> <td>N≤4</td> </tr> <tr> <td>2 DOTS ADJACENT (PAIR)</td> <td>N=0</td> </tr> <tr> <td>3 DOTS ADJACENT OR MORE</td> <td>N=0</td> </tr> <tr> <td rowspan="2">DISTANCE</td> <td>MINIMUM DISTANCE BETWEEN BRIGHT DOTS</td> <td>—</td> </tr> <tr> <td>MINIMUM DISTANCE BETWEEN DARK DOTS</td> <td>L≥5mm</td> </tr> <tr> <td colspan="2">TOTAL BRIGHT AND DARK DOT</td> <td>N≤6</td> </tr> <tr> <td colspan="2">SMALL BRIGHT DOT</td> <td>N≤3 DISTANCE≤5mm N≤5 DISTANCE≥5mm</td> </tr> <tr> <td colspan="2">MICRO BRIGHT DOT(ND 8% NOT OBSERVED)</td> <td>N=0</td> </tr> <tr> <td colspan="2">DISPLAY FAILURE (V-LINE/H-LINE/CROSS LINE ETC.)</td> <td>NOT ALLOWABLE</td> </tr> <tr> <td>MURA</td> <td>JUDGE BY LIMIT SAMPLE OR NOT VISIBLE THROUGH ND FILTER</td> <td>ND 5%</td> </tr> </tbody> </table> <p>NOTE :</p> <p>(1)THE DEFINITION OF DOT: DOTS THAT CAN BE SEEN THROUGH A 8% ND FILTER,AND THE SIZE OF A DEFECTIVE DOT OVER IS 1/2 OF WHOLE DOT.</p> <p>(2)BRIGHT DOT: DOTS THAT CAN BE SEEN THROUGH A 8% ND FILTER, AND THE SIZE OF A DEFECTIVE DOT IS THE WHOLE DOT.</p> <p>(3)DARK DOT: DOTS APPEAR DARK AND UNCHANGED IN SIZE IN WHICH LCD PANEL IS DISPLAYING UNDER PURE RED, GREEN, BLUE PICTURE.</p> <p>(4)MICRO BRIGHT DOT: DOTS THAT CANNOT BE SEEN THROUGH A 8% ND FILTER, AND THE SIZE OF A DEFECTIVE DOT IS THE WHOLE DOT.</p> <p>(5)SMALL BRIGHT DOT: THE SIZE OF A DEFECTIVE DOT IS LESS THAN 1/2 OF WHOLE DOT.</p> <p>(6)2 DOT ADJACENT=1PAIR=2DOTS.</p> <div style="display: flex; justify-content: space-around; align-items: center;"> <div style="text-align: center;">  <p>2 dot adjacent</p> </div> <div style="text-align: center;">  <p>2 dot adjacent</p> </div> <div style="text-align: center;">  <p>2 dot adjacent(vertical)</p> </div> <div style="text-align: center;">  <p>2 dot adjacent(slant)</p> </div> </div>	ITEM		STANDARD			Z	BRIGHT DOT	RANDOM	N≤2	2 DOTS ADJACENT (PAIR)	N=0	3 DOTS ADJACENT OR MORE	N=0	DARK DOT	RANDOM	N≤4	2 DOTS ADJACENT (PAIR)	N=0	3 DOTS ADJACENT OR MORE	N=0	DISTANCE	MINIMUM DISTANCE BETWEEN BRIGHT DOTS	—	MINIMUM DISTANCE BETWEEN DARK DOTS	L≥5mm	TOTAL BRIGHT AND DARK DOT		N≤6	SMALL BRIGHT DOT		N≤3 DISTANCE≤5mm N≤5 DISTANCE≥5mm	MICRO BRIGHT DOT(ND 8% NOT OBSERVED)		N=0	DISPLAY FAILURE (V-LINE/H-LINE/CROSS LINE ETC.)		NOT ALLOWABLE	MURA	JUDGE BY LIMIT SAMPLE OR NOT VISIBLE THROUGH ND FILTER	ND 5%
ITEM		STANDARD																																								
		Z																																								
BRIGHT DOT	RANDOM	N≤2																																								
	2 DOTS ADJACENT (PAIR)	N=0																																								
	3 DOTS ADJACENT OR MORE	N=0																																								
DARK DOT	RANDOM	N≤4																																								
	2 DOTS ADJACENT (PAIR)	N=0																																								
	3 DOTS ADJACENT OR MORE	N=0																																								
DISTANCE	MINIMUM DISTANCE BETWEEN BRIGHT DOTS	—																																								
	MINIMUM DISTANCE BETWEEN DARK DOTS	L≥5mm																																								
TOTAL BRIGHT AND DARK DOT		N≤6																																								
SMALL BRIGHT DOT		N≤3 DISTANCE≤5mm N≤5 DISTANCE≥5mm																																								
MICRO BRIGHT DOT(ND 8% NOT OBSERVED)		N=0																																								
DISPLAY FAILURE (V-LINE/H-LINE/CROSS LINE ETC.)		NOT ALLOWABLE																																								
MURA	JUDGE BY LIMIT SAMPLE OR NOT VISIBLE THROUGH ND FILTER	ND 5%																																								
4	FOREIGN BLACK/WHITE/ BRIGHT LINE/ OF VIEWING AREA	<table border="1"> <thead> <tr> <th>LENGTH : L</th> <th>WIDTH : W</th> <th>PERMISSIBLE NO.</th> </tr> </thead> <tbody> <tr> <td>L ≤ 5</td> <td>W ≤ 0.05</td> <td>IGNORE</td> </tr> <tr> <td>L ≤ 5</td> <td>0.05 < W ≤ 0.1</td> <td>4</td> </tr> <tr> <td>L > 5</td> <td>W > 0.1</td> <td>NONE</td> </tr> </tbody> </table> <p>WIDTH : W mm, LENGTH : L mm</p>	LENGTH : L	WIDTH : W	PERMISSIBLE NO.	L ≤ 5	W ≤ 0.05	IGNORE	L ≤ 5	0.05 < W ≤ 0.1	4	L > 5	W > 0.1	NONE																												
LENGTH : L	WIDTH : W	PERMISSIBLE NO.																																								
L ≤ 5	W ≤ 0.05	IGNORE																																								
L ≤ 5	0.05 < W ≤ 0.1	4																																								
L > 5	W > 0.1	NONE																																								
5	FOREIGN MATTER \ BLACK SPOTS \ WHITE SPOTS \ DENT (INCLUDING LIGHT LEAKAGE DUE TO POLARIZING PLATES PINHOLES, ETC.)	<table border="1"> <thead> <tr> <th>AVERAGE DIAMETER (mm): D</th> <th>NUMBER OF PIECES PERMITTED</th> </tr> </thead> <tbody> <tr> <td>D ≤ 0.25</td> <td>IGNORE</td> </tr> <tr> <td>0.25 < D ≤ 0.5</td> <td>4</td> </tr> <tr> <td>0.5 < D</td> <td>NONE</td> </tr> </tbody> </table> <p>NOTE : DIAMETER D=(a+b)/2</p> 	AVERAGE DIAMETER (mm): D	NUMBER OF PIECES PERMITTED	D ≤ 0.25	IGNORE	0.25 < D ≤ 0.5	4	0.5 < D	NONE																																
AVERAGE DIAMETER (mm): D	NUMBER OF PIECES PERMITTED																																									
D ≤ 0.25	IGNORE																																									
0.25 < D ≤ 0.5	4																																									
0.5 < D	NONE																																									

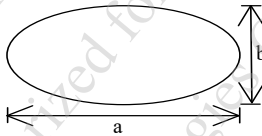
NO.	ITEM	CRITERIA		
			AVERAGE DIAMETER (mm) : D	NUMBER OF PIECES PERMITTED
6	BUBBLES ON POLARIZER /SURFACE STAINS /DIRT/CF FAIL/SPOT	BUBBLE ON THE POLARIZER	$D \leq 0.25$	IGNORE
			$0.25 < D \leq 0.5$	4
			$D > 0.5$	0
		POLARIZER SCRATCH	$W < 0.05$	IGNORE
			$0.05 < W \leq 0.1, 2 < L \leq 5$	4
			$W > 0.1$	0
		CF FAIL / SPOT	$D < 0.25$	IGNORE
			$0.25 < D \leq 0.5$	4
			$D > 0.5$	0
<p>NOTE : (1)POLARIZER BUBBLE IS DEFINED AS THE BUBBLE APPEARS ON ACTIVE DISPLAY AREA. THE DEFECT OF POLARIZER BUBBLE SHALL BE IGNORED IF THE POLARIZER BUBBLE APPEARS ON THE OUTSIDE OF ACTIVE DISPLAY AREA.</p> <p>(2)THE EXTRANEIOUS SUBSTANCE IS DEFINED AS IT CAN BE OBSERVED WHEN THE MODULE IS POWER ON.</p> <p>(3)THE DEFINITION OF AVERAGE DIAMETER, D IS DEFINED AS FOLLOWING.</p> <p>AVERAGE DIAMETER (D)=(a+b)/2</p> 				
7	LINE DEFECT ON DISPLAY	OBVIOUS VERTICAL OR HORIZONTAL LINE DEFECT IS NOT ALLOWED		
8	MURA ON DISPLAY	IT'S OK IF MURA IS SLIGHT VISIBLE THROUGH 5% ND FILTER		
9	UNEVEN COLOR SPREAD, COLORATION	TO BE DETERMINED BASED UPON THE LIMITED SAMPLE.		
10	BEZEL APPEARANCE	<p>(1)BEZEL MAY NOT HAVE RUST, BE DEFORMED OR HAVE FINGER PRINTS STAINS OF OTHER CONTAMINATION.</p> <p>(2)BEZEL MUST COMPLY WITH JOB SPECIFICATIONS.</p>		
11	PCB	<p>(1)THERE MAY NOT BE MORE THAN 2mm OF SEALANT OUTSIDE THE SEAL AREA ON THE PCB, AND THERE SHOULD BE NO MORE THAN THREE PLACES.</p> <p>(2)NO OXIDATION OR CONTAMINATION PCB TERMINALS.</p> <p>(3)PARTS ON PCB MUST BE THE SAME AS ON THE PRODUCTION CHARACTERISTIC CHART. THERE SHOULD BE NO WRONG PARTS, MISSING PARTS OR EXCESS PARTS.</p> <p>(4)THE JUMPER ON THE PCB SHOULD CONFORM TO THE PRODUCT CHARACTERISTIC CHART.</p> <p>(5)IF SOLDER GETS ON BEZEL TAB PADS, LED PAD, ZEBRA PAD OR SCREW HOLD PAD; MAKE SURE IT IS SMOOTHED DOWN.</p>		

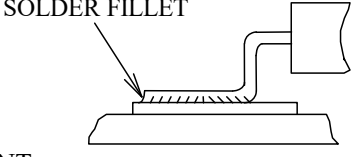
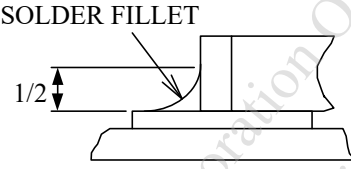
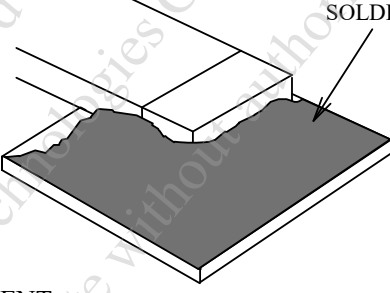
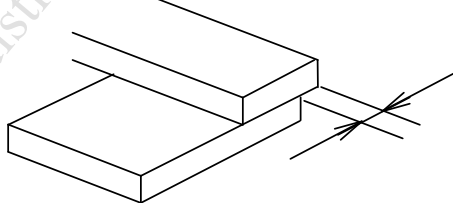
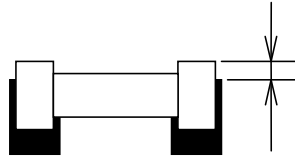
NO.	ITEM	CRITERIA
12	SOLDERING	<p>(1)NO SOLDERING FOUND ON THE SPECIFIED PLACE</p> <p>(2)INSUFFICIENT SOLDER</p> <p>(a)LSI, IC A POOR WETTING OF SOLDER IS BETWEEN LOWER BEND OR "HEEL" OF LEAD AND PAD</p>  <p>(b)CHIP COMPONENT · SOLDER IS LESS THAN 50% OF SIDES AND FRONT FACE WETTING</p>  <p>· SOLDER WETS 3 SIDES OF TERMINAL, BUT LESS THAN 25% OF SIDES AND FRONT SURFACE AREA ARE COVERED</p>  <p>(3)PARTS ALIGNMENT</p> <p>(a)LSI, IC LEAD WIDTH IS MORE THAN 50% BEYOND PAD OUTLINE</p>  <p>(b)CHIP COMPONENT COMPONENT IS OFF CENTER, AND MORE THAN 50% OF THE LEADS IS OFF THE PAD OUTLINE</p>  <p>(4)NO UNMELTED SOLDER PASTE MAY BE PRESENT ON THE PCB. (5)NO COLD SOLDER JOINTS, MISSING SOLDER CONNECTIONS, OXIDATION OR ICICLE. (6)NO RESIDUE OR SOLDER BALLS ON PCB. (7)NO SHORT CIRCUITS IN COMPONENTS ON PCB.</p>

NO.	ITEM	CRITERIA
13	BACKLIGHT	(1)NO LIGHT (2)FLICKERING AND OTHER ABNORMAL ILLUMINATION (3)SPOTS OR SCRATCHES THAT APPEAR WHEN LIT MUST BE JUDGED USING LCD SPOT, LINES AND CONTAMINATION STANDARDS. (4)BACKLIGHT DOESN'T LIGHT OR COLOR IS WRONG.
14	GENERAL APPEARANCE	(1)NO OXIDATION, CONTAMINATION, CURVES OR, BENDS ON INTERFACE PIN (OLB) OF TCP. (2)NO CRACKS ON INTERFACE PIN (OLB) OF TCP. (3)NO CONTAMINATION, SOLDER RESIDUE OR SOLDER BALLS ON PRODUCT. (4)THE IC ON THE TCP MAY NOT BE DAMAGED, CIRCUITS. (5)THE UPPERMOST EDGE OF THE PROTECTIVE STRIP ON THE INTERFACE PIN MUST BE PRESENT OR LOOK AS IF IT CAUSE THE INTERFACE PIN TO SEVER. (6)THE RESIDUAL ROSIN OR TIN OIL OF SOLDERING (COMPONENT OR CHIP COMPONENT) IS NOT BURNED INTO BROWN OR BLACK COLOR. (7)SEALANT ON TOP OF THE ITO CIRCUIT HAS NOT HARDENED. (8)PIN TYPE MUST MATCH TYPE IN SPECIFICATION SHEET. (9)LCD PIN LOOSE OR MISSING PINS. (10)PRODUCT PACKAGING MUST BE THE SAME AS SPECIFIED ON PACKAGING SPECIFICATION SHEET. (11)PRODUCT DIMENSION AND STRUCTURE MUST CONFORM TO PRODUCT SPECIFICATION SHEET. (12)THE APPEARANCE OF HEAT SEAL SHOULD NOT ADMIT ANY DIRT AND BREAK.

CONFIDENTIAL
 Emerging Display Technologies Corporation
 Do not distribute without authorization

13. RELIABILITY TEST

13.1 STANDARD SPECIFICATIONS FOR RELIABILITY OF LCD MODULE

NO.	ITEM	DESCRIPTION
1	HIGH TEMPERATURE TEST (OPERATION)	THE SAMPLE SHOULD BE ALLOWED TO STAND AT +85°C FOR 240 HRS
2	LOW TEMPERATURE TEST (OPERATION)	THE SAMPLE SHOULD BE ALLOWED TO STAND AT -30°C FOR 240 HRS
3	HIGH TEMPERATURE TEST (STORAGE)	THE SAMPLE SHOULD BE ALLOWED TO STAND AT +85°C FOR 240 HRS
4	LOW TEMP TEST (STORAGE)	THE SAMPLE SHOULD BE ALLOWED TO STAND AT -30°C FOR 240 HRS
5	HIGH TEMPERATURE /HUMIDITY TEST (STORAGE)	THE SAMPLE SHOULD BE ALLOWED TO STAND AT 40°C , 90% RH 240 HRS
6	THERMAL SHOCK (NOT OPERATED)	<p>THE SAMPLE SHOULD BE ALLOWED TO STAND THE FOLLOWING 10 CYCLES OF OPERATION:</p> <p>The diagram shows a temperature profile for one cycle of thermal shock. It starts at -30°C, ramps up to +85°C (30 min ramp), stays at +85°C (3 min dwell), ramps down to -30°C (30 min ramp), and stays at -30°C (3 min dwell). This sequence is labeled as '1 CYCLE'.</p>
7	ESD (ELECTROSTATIC DISCHARGE) (NOT OPERATED)	AIR DISCHARGE ± 12KV CONTACT DISCHARGE ± 8KV (ACCORDING TO IEC-61000-4-2)

NOTE (1) : THE TEST SAMPLES HAVE RECOVERY TIME FOR 2 HOURS AT ROOM TEMPERATURE BEFORE THE FUNCTION CHECK. IN THE STANDARD CONDITIONS, THERE IS NO DISPLAY FUNCTION NG ISSUE OCCURRED.

NOTE (2) : WHEN THE LCD MODULE IS OPERATED AT AMBIENT TEMPERATURE 60°C, THE PWM DUTY CYCLE OF THE LED BACKLIGHT SHOULD BE ADJUSTED TO BE LESS THAN 50%. IF THE MODULE IS OPERATED AT A HIGHER DUTY CYCLE THAN 50%, THEN THERE IS A POSSIBILITY OF DISTORTION AND IRREGULARITY OF THE PICTURE DUE TO LIQUID CRYSTAL BEHAVIOR.

NOTE (3) : TESTING CONDITIONS AND INSPECTION CRITERIA

NO.	ITEM	TEST MODEL	INSPECTION CRITERIA
1	CURRENT CONSUMPTION	REFER TO SPECIFICATION	THE CURRENT CONSUMPTION SHOULD CONFORM TO THE PRODUCT SPECIFICATION.
2	CONTRAST	REFER TO SPECIFICATION	AFTER THE TESTS HAVE BEEN EXECUTED, THE CONTRAST MUST BE LARGER THAN HALF OF ITS INITIAL VALUE PRIOR TO THE TESTS.
3	APPEARANCE	VISUAL INSPECTION	DEFECT FREE

14. CAUTION

14.1 OPERATION

- 14.1.1 DO NOT CONNECT OR DISCONNECT MODULES TO OR FROM THE MAIN SYSTEM WHILE POWER IS BEING SUPPLIED .
- 14.1.2 USE THE MODULE WITHIN SPECIFIED TEMPERATURE ; LOWER TEMPERATURE CAUSES THE RETARDATION OF BLINKING SPEED OF THE DISPLAY ; HIGHER TEMPERATURE MAKES OVERALL DISPLAY DISCOLOR . WHEN THE TEMPERATURE RETURNS TO NORMALITY, THE DISPLAY WILL OPERATE NORMALLY.
- 14.1.3 ADJUST THE LC DRIVING VOLTAGE TO OBTAIN THE OPTIMUM CONTRAST .
- 14.1.4 POWER ON SEQUENCE INPUT SIGNALS SHOULD NOT BE SUPPLIED TO LCD MODULE BEFORE POWER SUPPLY VOLTAGE IS APPLIED AND REACHES THE SPECIFIED VALUE.
IF ABOVE SEQUENCE IS NOT FOLLOWED , CMOS LSIS OF LCD MODULES MAY BE DAMAGED DUE TO LATCH - UP PROBLEM.
- 14.1.5 NOT ALLOWED TO INFLICT ANY EXTERNAL STRESS AND TO CAUSE ANY MECHANICAL INTERFERENCE ON THE BENDING AREA OF FPC DURING THE TAIL BENDING BACKWARDS!
DO NOT STRESS FPC AND IC ON THE MODULE!

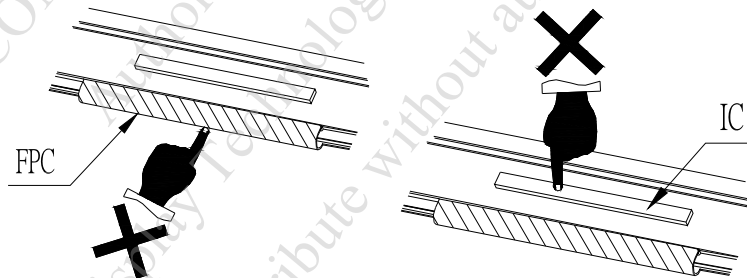

14.2 NOTICE

- 14.2.1 USE A GROUNDED SOLDERING IRON WHEN SOLDERING CONNECTOR I/O TERMINALS . FOR SOLDERING OR REPAIRING, TAKE PRECAUTION AGAINST THE TEMPERATURE OF THE SOLDERING IRON AND THE SOLDERING TIME TO PREVENT PEELING OFF THE THROUGH-HOLE-PAD .
- 14.2.2 DO NOT DISASSEMBLE . EDT SHALL NOT BE HELD RESPONSIBLE IF THE MODULE IS DISASSEMBLED AND UPON THE REASSEMBLY THE MODULE FAILED.
- 14.2.3 DO NOT CHARGE STATIC ELECTRICITY, AS THE CIRCUIT OF THIS MODULE CONTAINS CMOS LSIS. A WORKMAN'S BODY SHOULD ALWAYS BE STATIC-PROTECTED BY USE OF AN ESD STRAP. WORKING CLOTHES FOR SUCH PERSONNEL SHOULD BE OF STATIC-PROTECTED MATERIAL.
- 14.2.4 ALWAYS GROUND THE ELECTRICALLY-POWERED DRIVER BEFORE USING IT TO INSTALL THE LCD MODULE. WHILE CLEANING THE WORK STATION BY VACUUM CLEANER, DO NOT BRING THE SUCKING MOUTH NEAR THE MODULE ; STATIC ELECTRICITY OF THE ELECTRICALLY-POWERED DRIVER OR THE VACUUM CLEANER MAY DESTROY THE MODULE.
- 14.2.5 DON'T GIVE EXTERNAL SHOCK.
- 14.2.6 DON'T APPLY EXCESSIVE FORCE ON THE SURFACE.
- 14.2.7 LIQUID IN LCD IS HAZARDOUS SUBSTANCE. MUST NOT LICK AND SWALLOW.
WHEN THE LIQUID IS ATTACH TO YOUR, SKIN, CLOTH ETC. WASH IT OUT THOROUGHLY AND IMMEDIATELY.
- 14.2.8 DON'T OPERATE IT ABOVE THE ABSOLUTE MAXIMUM RATING.
- 14.2.9 STORAGE IN A CLEAN ENVIRONMENT, FREE FROM DUST, ACTIVE GAS, AND SOLVENT.
- 14.2.10 STORE WITHOUT ANY PHYSICAL LOAD.
- 14.2.11 REWIRING: NO MORE THAN 3 TIMES.