

EXAMINED BY :  <i>Dan Kao</i>	EMERGING DISPLAY  TECHNOLOGIES CORPORATION	FILE NO . CAS-P00824
APPROVED BY :  <i>Justin Horng</i>		ISSUE : MAY.22, 2020
		TOTAL PAGE : 25
		VERSION : P

CUSTOMER                      ACCEPTANCE                      SPECIFICATIONS

MODEL NO. :

ET070017ADM6

(RoHS)

FOR MESSRS :  
\_\_\_\_\_

CUSTOMER'S APPROVAL

DATE :  
\_\_\_\_\_

BY :  
\_\_\_\_\_

EMERGING DISPLAY  
TECHNOLOGIES CORPORATION

MODEL NO.	VERSION	PAGE
ET070017ADM6	P	0-1

RECORDS OF REVISION	DOC . FIRST ISSUE	MAY.22, 2020
---------------------	-------------------	--------------

DATE	REVISED PAGE NO.	SUMMARY
		<p style="text-align: center; opacity: 0.5; font-size: 2em;">CONFIDENTIAL</p> <p style="text-align: center; opacity: 0.5; font-size: 1.5em;">Authorized for Emerging Display Technologies Corporation Only. Do not distribute without authorization.</p>

TABLE OF CONTENTS

NO.	ITEM	PAGE
1.	GENERAL SPECIFICATIONS -----	1
2.	MECHANICAL SPECIFICATIONS -----	1
3.	ABSOLUTE MAXIMUM RATINGS -----	2
4.	ELECTRICAL CHARACTERISTICS -----	3
5.	TIMING CHARACTERISTICS -----	4 ~ 6
6.	OPTICAL CHARACTERISTICS -----	7, 8
7.	OUTLINE DIMENSIONS -----	9
8.	BLOCK DIAGRAM -----	10
9.	DETAIL DRAWING OF DOT MATRIX -----	11
10.	INTERFACE SIGNALS -----	12, 13
11.	POWER SUPPLY -----	14
12.	INSPECTION CRITERIA -----	15 ~ 25

CONFIDENTIAL  
 Authorized for  
 Emerging Display Technologies Corporation Only.  
 Do not distribute without authorization.

## 1. GENERAL SPECIFICATIONS

### 1.1 DATA SHEETS FOR CONTROLLER / DRIVER PLEASE REFER TO :

EK9713B  
EK73002AB2

### 1.2 MATERIAL SAFETY DESCRIPTION

ASSEMBLIES SHALL COMPLY WITH EUROPEAN ROHS REQUIREMENTS, INCLUDING PROHIBITED MATERIALS/COMPONENTS CONTAINING LEAD, MERCURY, CADMIUM, HEXAVALENT CHROMIUM, POLYBROMINATED BIPHENYLS (PBB) AND POLYBROMINATED DIPHENYL ETHERS (PBDE), BIS(2-ETHYLHEXYL) PHTHALATE (DEHP), BUTYL BENZYL PHTHALATE (BBP), DIBUTYL PHTHALATE (DBP), DIISOBUTYL PHTHALATE (DIBP).

## 2. MECHANICAL SPECIFICATIONS

( 1 ) DISPLAY SIZE	-----	7 inch
( 2 ) NUMBER OF DOTS	-----	800W * (RGB) * 480H DOTS
( 3 ) MODULE SIZE	-----	164.9W * 100H * 10D (MAX.) mm (WITHOUT FPC)
( 4 ) EFFECTIVE AREA	-----	156.08W * 88.53H mm
( 5 ) ACTIVE AREA	-----	154.08W * 85.92H mm
( 6 ) DOT SIZE	-----	0.0642W * 0.179H mm
( 7 ) PIXEL SIZE	-----	0.1926W * 0.179H mm
( 8 ) LCD TYPE	-----	TFT , TRANSMISSIVE, ANTE-GLARE
( 9 ) COLOR	-----	16.7M
( 10 ) VIEWING DIRECTION	-----	6 O'CLOCK (GRAY LEVEL INVERSION)
( 11 ) BACK LIGHT	-----	LED , COLOR : WHITE
( 12 ) INTERFACE MODE	-----	RGB(24BIT) PARALLEL (SYNC / DE MODE)

### 3. ABSOLUTE MAXIMUM RATINGS

#### 3.1 LCD MODULE ELECTRICAL ABSOLUTE MAXIMUM RATINGS

ITEM	SYMBOL	MIN.	MAX.	UNIT	REMARK
POWER SUPPLY VOLTAGE	VDD-VSS	-0.3	5	V	—

#### 3.2 ENVIRONMENTAL ABSOLUTE MAXIMUM RATINGS

ITEM	OPERATING		STORAGE		REMARK
	MIN.	MAX.	MIN.	MAX.	
AMBIENT TEMPERATURE	-20°C	70°C	-30°C	80°C	NOTE ( 1 ) , ( 2 ) , ( 3 )
HUMIDITY	NOTE ( 3 )		NOTE ( 3 )		WITHOUT CONDENSATION
VIBRATION	—	2.45 m/s <sup>2</sup> ( 0.25 G )	—	11.76 m/s <sup>2</sup> ( 1.2 G )	10~100 Hz XYZ DIRECTIONS 1 HR EACH
SHOCK	—	29.4 m/s <sup>2</sup> ( 3 G )	—	490 m/s <sup>2</sup> ( 50 G )	10 ms XYZ DIRECTIONS 1 TIME EACH
CORROSIVE GAS	NOT ACCEPTABLE		NOT ACCEPTABLE		

NOTE ( 1 ) : THE ABSOLUTE MAXIMUM RATINGS OF THIS PRODUCT SHOULD NOT BE EXCEEDED AT ANY TIME. IF THESE RATINGS ARE EXCEEDED, THE PRODUCT'S PERFORMANCE IS NOT GUARANTEED AND THE PRODUCT MAY EXPERIENCE PERMANENT DAMAGE.

NOTE ( 2 ) : BACKGROUND COLOR CHANGES SLIGHTLY DEPENDING ON AMBIENT TEMPERATURE THIS PHENOMENON IS REVERSIBLE.

NOTE ( 3 ) : Ta ≤ 50°C : 85%RH MAX. (48HRS MAX).

Ta > 50°C : ABSOLUTE HUMIDITY MUST BE LOWER THAN THE HUMIDITY OF 85%RH AT 50°C(48HRS MAX).

#### 4. ELECTRICAL CHARACTERISTICS

##### 4.1 LCD MODULE ELECTRICAL CHARACTERISTICS

Ta = 25 °C

ITEM	SYMBOL	CONDITION	MIN.	TYP.	MAX.	UNIT	REMARK
POWER SUPPLY VOLTAGE	VDD-VSS	—	3.15	3.3	3.45	V	
POWER SUPPLY VOLTAGE FOR LED DRIVER	VBL+VBL-	—	4.7	5	5.3	V	
LOGIC LOW INPUT VOLTAGE	VIL	—	VSS	—	0.3*VDD	V	
LOGIC HIGH INPUT VOLTAGE	VIH	—	0.7*VDD	—	VDD	V	
POWER SUPPLY CURRENT	IDD	VDD-VSS = 3.3V	—	(100)	(150)	mA	NOTE ( 1 )
POWER SUPPLY CURRENT FOR LED DRIVER	IBL	VBL+ - VBL- = 5V LED B/L=ON	—	(400)	(450)	mA	
LED LIFE TIME	—	IF=20mA (PER LED)	30K	—	—	HRS	NOTE ( 2 ) NOTE ( 3 )

NOTE ( 1 ) : TYP. SPECIFICATION : GRAY-LEVEL TEST PATTERN  
MAX. SPECIFICATION : BLACK TEST PATTERN.



(a) GRAY-LEVEL PATTERN



(b) BLACK PATTERN

NOTE ( 2 ) : CONDITIONS; Ta=25 °C, CONTINUOUS LIGHTING

NOTE ( 3 ) : DEFINITIONS OF LIFE TIME :

LCD LUMINANCE BECOMES HALF OF THE INITIAL VALUE.

## 5. TIMING CHARACTERISTICS

### 5.1 LCD MODULE AC ELECTRICAL CHARACTERISTICS

ITEM	SYMBOL	MIN.	TYP.	MAX.	UNIT	CONDITIONS
VDD POWER ON SLEW RATE	T <sub>POR</sub>	1	10	20	ms	FROM 0V to 90% VDD
RESET PULSE WIDTH	T <sub>RST</sub>	1	2	5	ms	Clkin=40MHz
DCLK CYCLE TIME	T <sub>cph</sub>	20	30	40	ns	
DCLK PULSE DUTY	T <sub>cwh</sub>	40	50	60	%	
VSYNC SETUP TIME	T <sub>vst</sub>	8	10	20	ns	
VSYNC HOLD TIME	T <sub>vhd</sub>	8	96000	64000	ns	
HSYNC SETUP TIME	T <sub>hst</sub>	8	10	20	ns	
HSYNC HOLD TIME	T <sub>hhd</sub>	8	120	800	ns	
DATA SETUP TIME	T <sub>dsu</sub>	8	10	20	ns	D[7:0], D1[7:0], D2[7:0] to Clkin
DATA HOLD TIME	T <sub>dhd</sub>	8	15	20	ns	D[7:0], D1[7:0], D2[7:0] to Clkin
DE SETUP TIME	T <sub>esu</sub>	8	15	20	ns	
DE HOLD TIME	T <sub>ehd</sub>	8	15	20	ns	
OUTPUT STABLE TIME	T <sub>sst</sub>	—	—	6	us	10% TO 90% TARGET VOLTAGE. CL=120pF, R=10Kohm
DCLK CYCLE TIME	T <sub>clk</sub>	20	30	40	ns	
DCLK PULSE DUTY	T <sub>cwh</sub>	40	50	60	%	T <sub>clk</sub>
TIME FROM HSYNC TO SOURCE OUTPUT	T <sub>hso</sub>	—	64	—	DCLK	

INPUT CLOCK AND DATA TIMING DIAGRAM

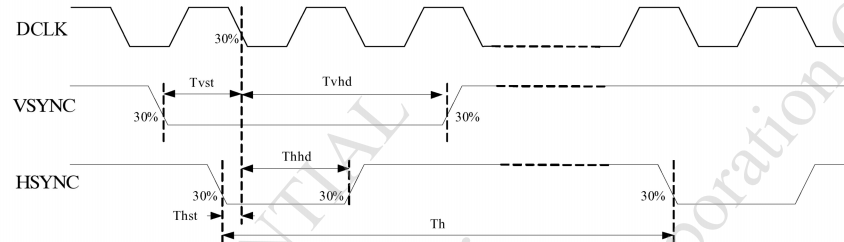
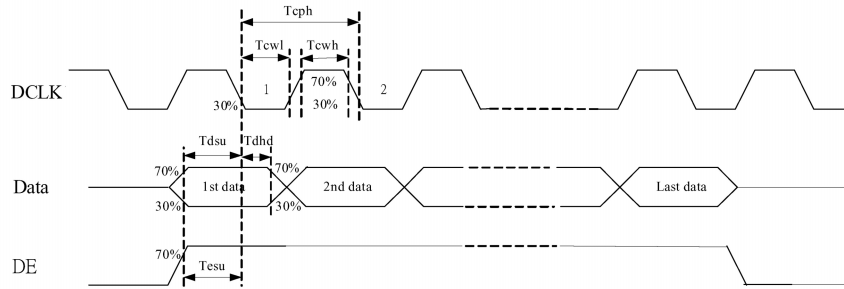

SOURCE OUTPUT TIMING DIAGRAM

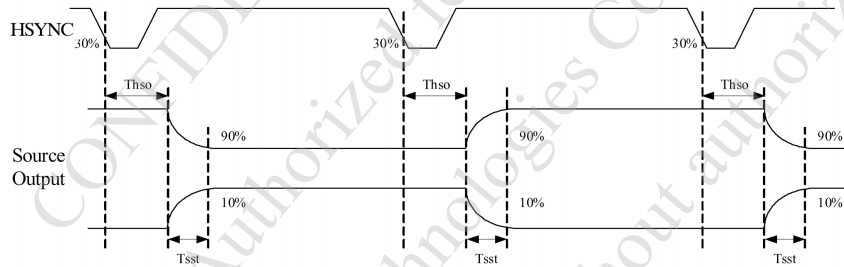

VERTICAL TIMING DIAGRAM SYNC (TCON + SOURCE MODE)

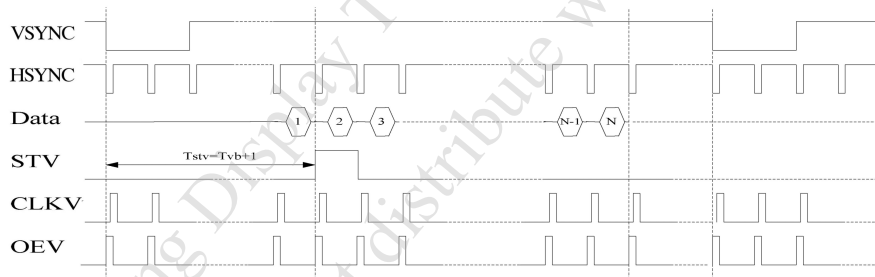

VERTICAL TIMING DIAGRAM DE (TCON + SOURCE MODE)

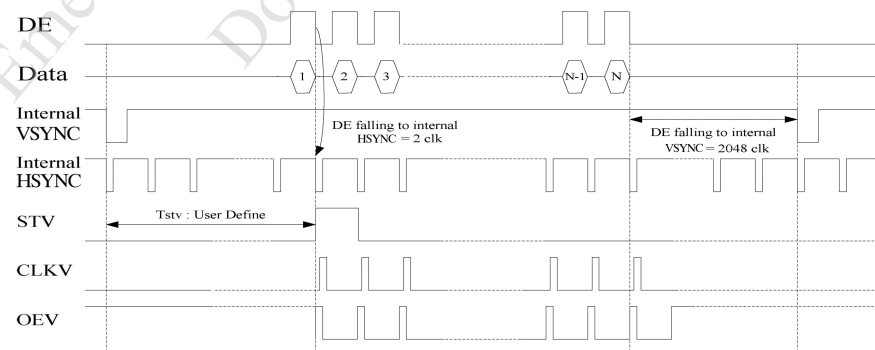

5.2 LCD MODULE TIMING CHARACTERISTICS

ITEM	SYMBOL	MIN.	TYP.	MAX.	UNIT	REMARK
HORIZONTAL DISPLAY AREA	thd	800			DCLK	
DCLK FREQUENCY	fclk	26.4	33.3	46.8	MHz	
ONE HORIZONTAL LINE	th	862	1056	1200	DCLK	
HSYNC PULSE WIDTH	thpw	1	6	40	DCLK	NOTE ( 1 )
HSYNC BACK PORCH (BLANKING)	thb	46			DCLK	NOTE ( 1 )
HSYNC FRONT PORCH	thfb	16	210	354	DCLK	
DE MODE BLANKING	th-thd	62	256	400	DCLK	
VERTICAL DISPLAY AREA	tvd	480			H	
VSYNC PERIOD TIME	tv	510	525	650	H	
VSYNC PULSE WIDTH	tvpw	1	3	20	H	NOTE ( 2 )
VSYNC BACK PORCH (BLANKING)	tvb	23			H	NOTE ( 2 )
VSYNC FRONT PORCH	tvfb	7	22	147	H	
DE MODE BLANKING	tv-tvd	30	45	170	H	

NOTE ( 1 ) : HS BLANKING HAS INCLUDED HS PULSE WIDTH.

NOTE ( 2 ) : VS BLANKING HAS INCLUDED VS PULSE WIDTH.

VERTICAL INPUT TIMING

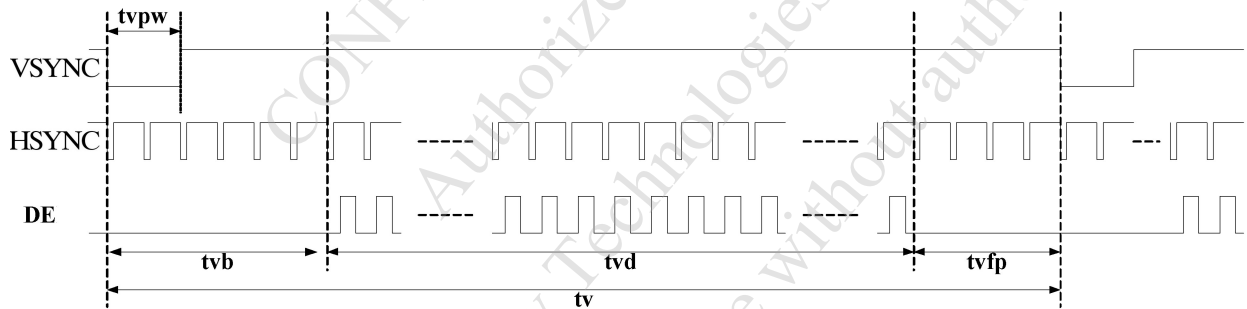

HORIZONTAL INPUT TIMING

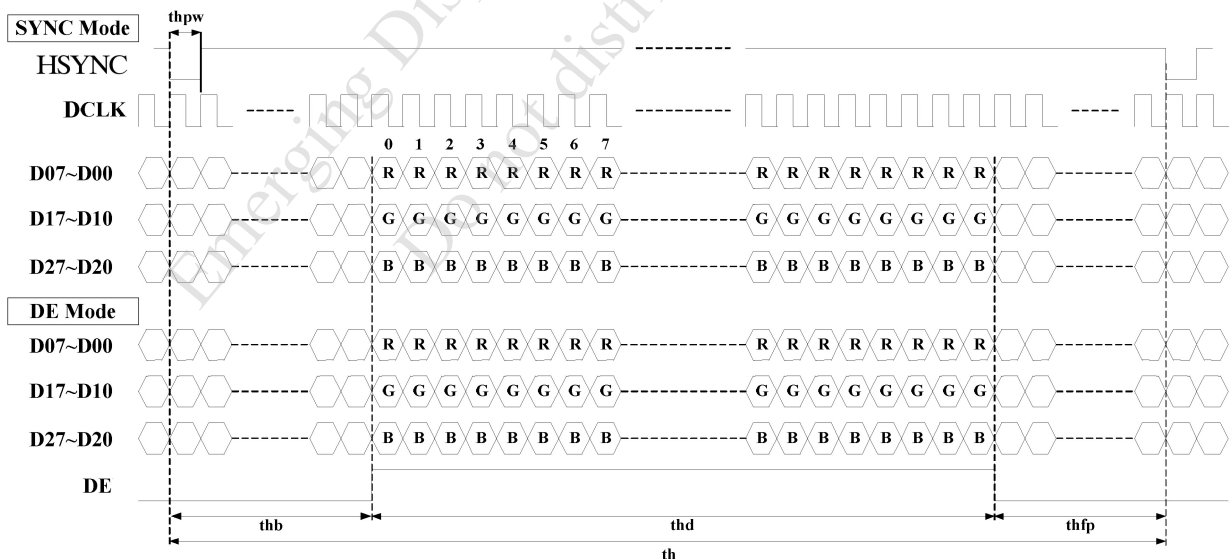

6. OPTICAL CHARACTERISTICS (NOTE 1)

6.1 OPTICAL CHARACTERISTICS

Ta=25±2°C

ITEM	SYMBOL	CONDITION	MIN.	TYP.	MAX.	UNIT	REMARK	
VIEWING ANGLE	$\theta_{y+}$	$CR \geq 10$	$\theta_x=0^\circ$	(40)	(50)	—	deg.	NOTE ( 2 ) NOTE ( 3 )
	$\theta_{y-}$			(60)	(70)	—		
	$\theta_{x+}$		$\theta_y=0^\circ$	(60)	(70)	—		
	$\theta_{x-}$			(60)	(70)	—		
CONTRAST RATIO (CENTER)	CR	$\theta_x=0^\circ, \theta_y=0^\circ$	400	500	—	—	NOTE ( 3 )	
RESPONSE TIME	Tr + Tf		—	25	50	msec	NOTE ( 4 )	
COLOR CHROMATICITY (CENTER)	WHITE	Wx	$\theta_x=0^\circ, \theta_y=0^\circ$ VBL+—VBL-=5V	(0.26)	(0.31)	(0.36)	—	NOTE ( 5 )
		Wy		(0.29)	(0.34)	(0.39)		
	RED	Rx		TBD	TBD	TBD	—	
		Ry		TBD	TBD	TBD		
	GREEN	Gx		TBD	TBD	TBD	—	
		Gy		TBD	TBD	TBD		
	BLUE	Bx		TBD	TBD	TBD	—	
		By		TBD	TBD	TBD		
THE BRIGHTNESS OF MODULE (CENTER)	B	$\theta_x=0^\circ, \theta_y=0^\circ$	(297)	(340)	—	cd/m <sup>2</sup>	NOTE ( 6 )	
THE UNIFORMITY OF MODULE	—	VBL+—VBL-=5V	70	75	—	%	NOTE ( 7 )	

NOTE ( 1 ) : TEST CONDITION :

AFTER STABILIZING AND LEAVING THE PANEL ALONE AT A GIVEN TEMPERATURE FOR 30 MINUTES. MEASUREMENT SHOULD BE EXECUTED IN A STABLE, WINDLESS, AND DARK ROOM.

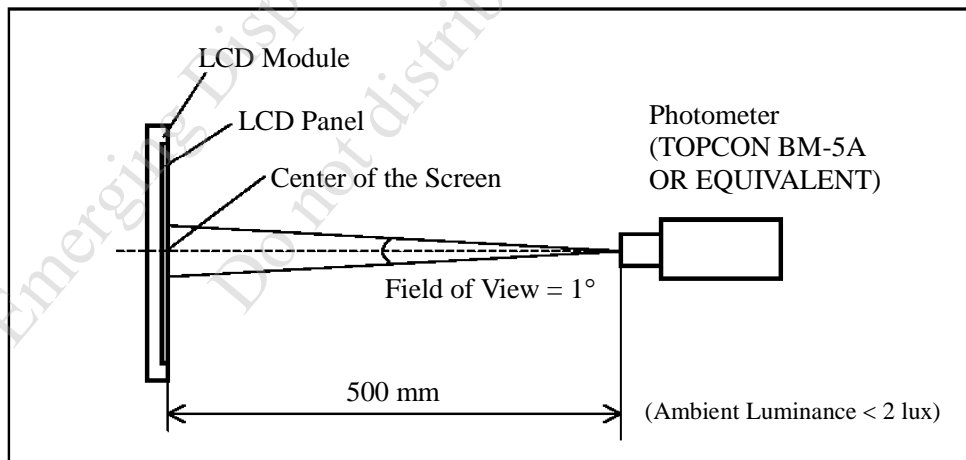

NOTE ( 2 ) : DEFINITION OF VIEWING ANGLE :

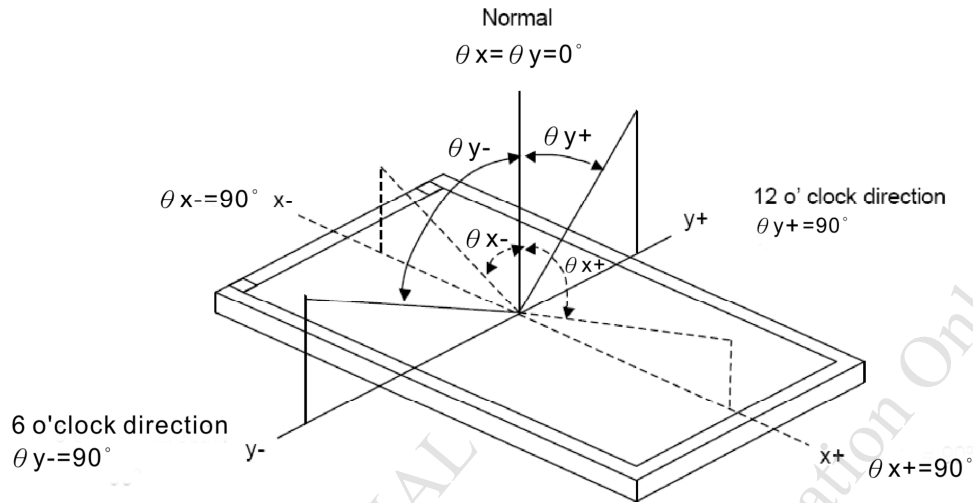

NOTE ( 3 ) : DEFINITION OF CONTRAST RATIO (CR) :  
MEASURED AT THE CENTER POINT OF MODULE

$$\text{CONTRAST RATIO(CR)} = \frac{\text{BRIGHTNESS MEASURED WHEN LCD IS AT "WHITE STATE"}}{\text{BRIGHTNESS MEASURED WHEN LCD IS AT "BLACK STATE"}}$$

NOTE ( 4 ) : DEFINITION OF RESPONSE TIME :  $T_R$  AND  $T_F$

THE FIGURE BELOW IS THE OUTPUT SIGNAL OF THE PHOTO DETECTOR.

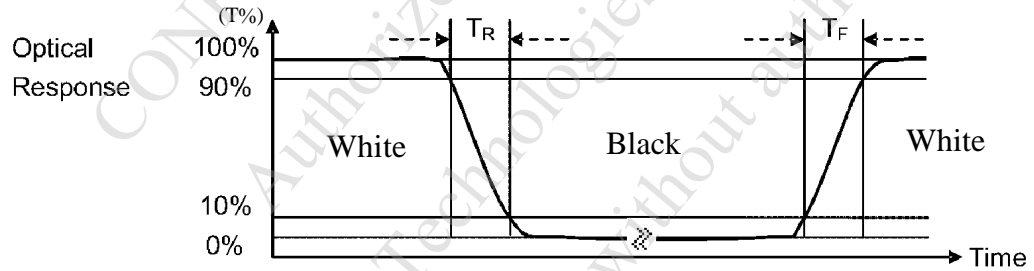

NOTE ( 5 ) : DEFINITION OF COLOR CHROMATICITY

(a)100% RGB PIXEL DATA TRANSMISSION WHEN ALL THE INPUT TERMINALS OF MODULE ARE ELECTRICALLY POWERED ON.

(b)MEASURED AT THE CENTER POINT OF MODULE

NOTE ( 6 ) : MEASURED THE BRIGHTNESS OF WHITE STATE AT CENTER POINT.

NOTE ( 7 ) : (a)DEFINITION OF BRIGHTNESS UNIFORMITY

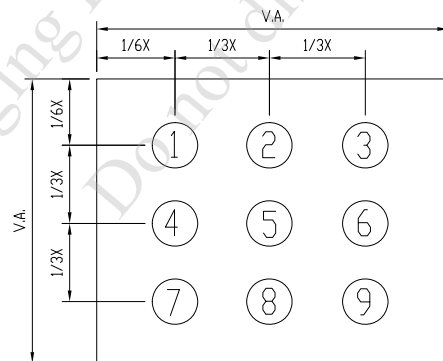

UNIT : mm

(b)THE BRIGHTNESS UNIFORMITY CALCULATING METHOD

$$\text{UNIFORMITY} : \frac{\text{MINIMUM BRIGHTNESS}}{\text{MAXIMUM BRIGHTNESS}} * 100\%$$

7. OUTLINE DIMENSIONS

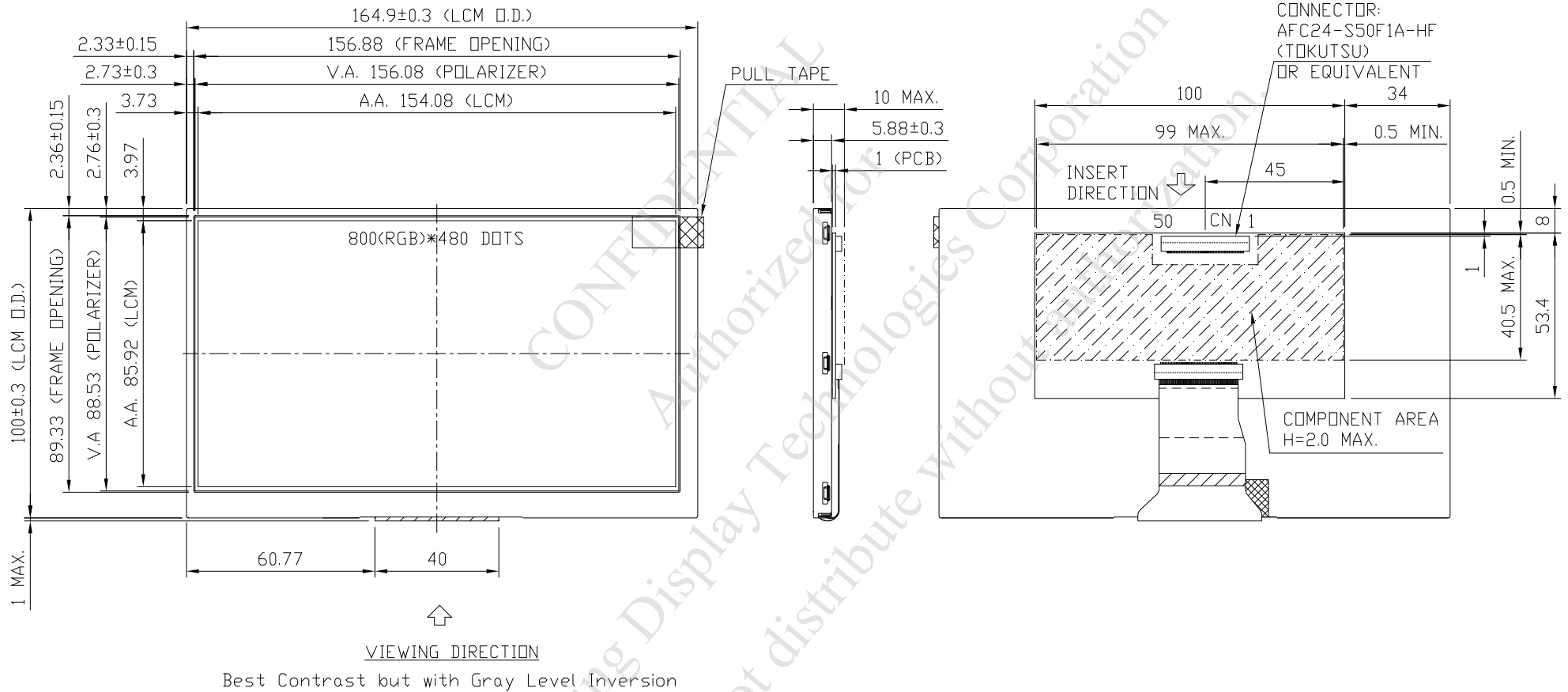

UNIT : mm  
 SCALE : NTS  
 NOT SPECIFIED TOLERANCE IS ± 0.5

8. BLOCK DIAGRAM

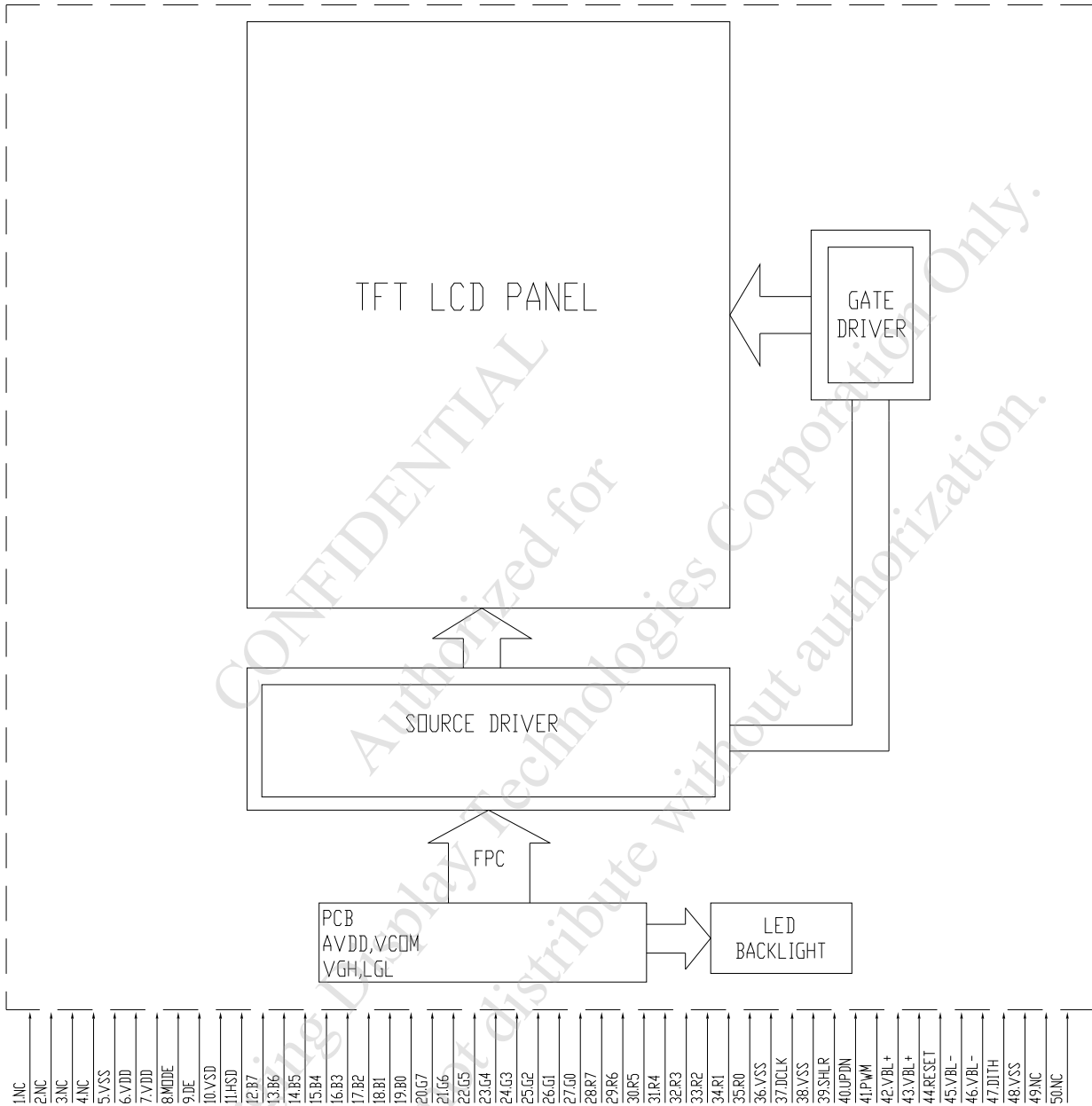

9. DETAIL DRAWING OF DOT MATRIX

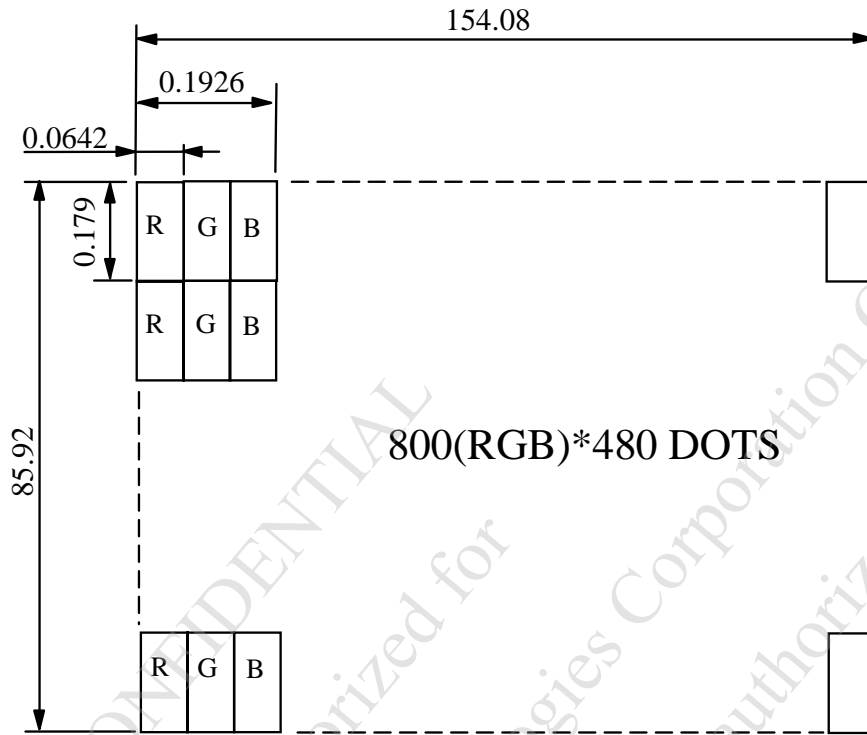

UNIT : mm  
SCALE : NTS  
NOT SPECIFIED TOLERANCE IS  $\pm 0.1$   
DOTS MATRIX TOLERANCE IS  $\pm 0.01$

10. INTERFACE SIGNALS

PIN NO.	SYMBOL	I/O/P	FUNCTION
1	NC	P	NO CONNECTION
2	NC	P	NO CONNECTION
3	NC	P	NO CONNECTION
4	NC	P	NO CONNECTION
5	VSS	P	POWER GROUND
6	VDD	P	POWER SUPPLY
7	VDD	P	POWER SUPPLY
8	MODE	I	DE/SYNC MODE SELECT. NORMALLY PULL HIGH H: DE MODE. L: HSD/VSD MODE
9	DE	I	DATA INPUT ENABLE
10	VSD	I	VERTICAL SYNC INPUT. NEGATIVE POLARITY
11	HSD	I	HORIZONTAL SYNC INPUT. NEGATIVE POLARITY
12	B7	I	BLUE DATA(MSB)
13	B6	I	BLUE DATA
14	B5	I	BLUE DATA
15	B4	I	BLUE DATA
16	B3	I	BLUE DATA
17	B2	I	BLUE DATA
18	B1	I	BLUE DATA
19	B0	I	BLUE DATA(LSB)
20	G7	I	GREEN DATA(MSB)
21	G6	I	GREEN DATA
22	G5	I	GREEN DATA
23	G4	I	GREEN DATA
24	G3	I	GREEN DATA
25	G2	I	GREEN DATA
26	G1	I	GREEN DATA
27	G0	I	GREEN DATA(LSB)
28	R7	I	RED DATA(MSB)
29	R6	I	RED DATA
30	R5	I	RED DATA
31	R4	I	RED DATA
32	R3	I	RED DATA
33	R2	I	RED DATA
34	R1	I	RED DATA
35	R0	I	RED DATA(LSB)
36	VSS	P	POWER GROUND
37	DCLK	I	CLOCK INPUT
38	VSS	P	POWER GROUND
39	SHLR	I	LEFT OR RIGHT DISPLAY CONTROL
40	UPDN	I	UP / DOWN DISPLAY CONTROL
41	PWM	P	ADJUST FOR LED BRIGHTNESS
42	VBL+	P	POWER SUPPLY VOLTAGE FOR LED BACKLIGHT
43	VBL+	P	POWER SUPPLY VOLTAGE FOR LED BACKLIGHT

PIN NO.	SYMBOL	I/O/P	FUNCTION
44	RESET	I	GLOBAL RESET PIN. ACTIVE LOW TO ENTER RESET STATE. SUGGEST TO CONNECTING WITH AN RC RESET CIRCUIT FOR STABILITY. NORMALLY PULL HIGH. (R=10KΩ, C=1μF)
45	VBL-	P	LED BACKLIGHT GROUND
46	VBL-	P	LED BACKLIGHT GROUND
47	DITH	I	DITHERING SETTING DITH=" H " 6BIT RESOLUTION (LAST 2 BIT OF INPUT DATA TRUNCATED) DITH=" L " 8BIT RESOLUTION (DEFAULT SETTING)
48	VSS	P	POWER GROUND
49	NC	P	NO CONNECTION
50	NC	P	NO CONNECTION

NOTE (1) : SHLR : LEFT OR RIGHT SETTING  
UPDN : UP OR DOWN SETTING

SHLR	UPDN	DATA SHIFTING
VDD	VSS	LEFT TO RIGHT, UP TO DOWN (DEFAULT)
VSS	VSS	RIGHT TO LEFT, UP TO DOWN
VDD	VDD	LEFT TO RIGHT, DOWN TO UP
VSS	VDD	RIGHT TO LEFT, DOWN TO UP

NOTE (2) : DEFINITION OF SCANNING DIRECTION.  
REFER TO THE FIGURE AS BELOW :

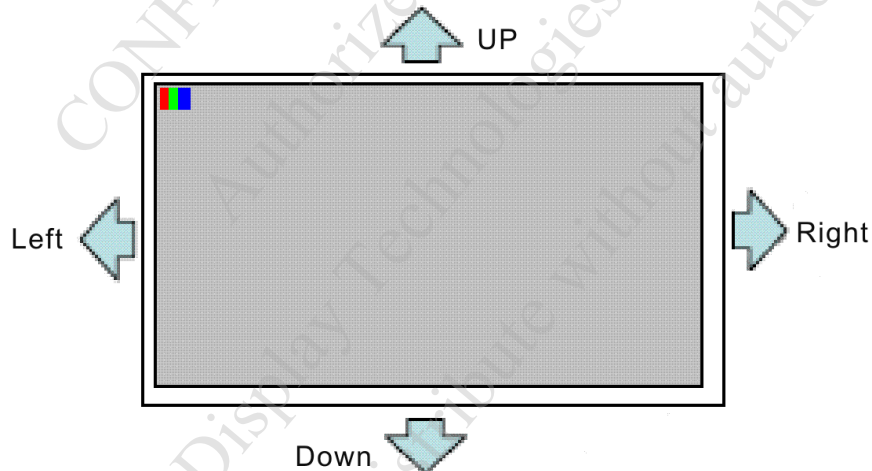

11. POWER SUPPLY

11.1 POWER SUPPLY FOR LCM

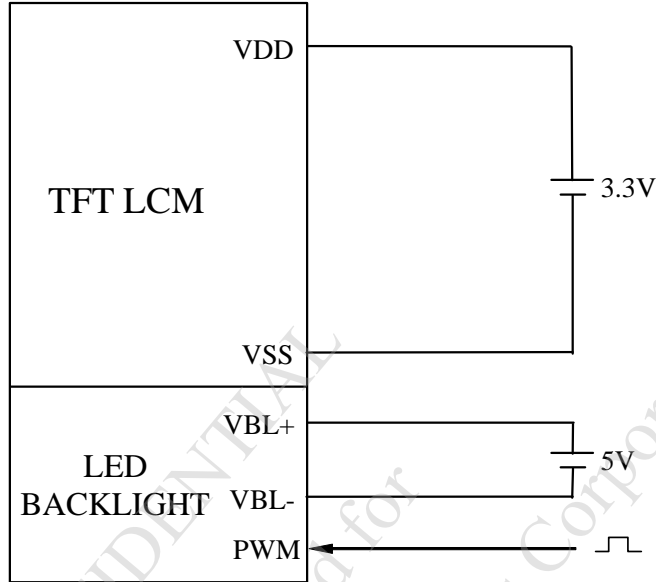

NOTE ( 1 ) : ADJUST THE PWM SIGNAL IN ORDER TO CONTROL LED BACKLIGHT'S BRIGHTNESS. THE HIGHER THE DUTY CYCLE, THE HIGHER THE BRIGHTNESS

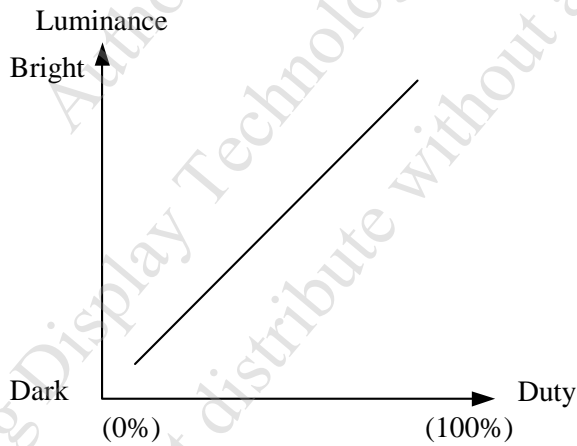

NOTE ( 2 ) : PWM SIGNAL OPERATION FREQUENCY IS 100~10KHz.

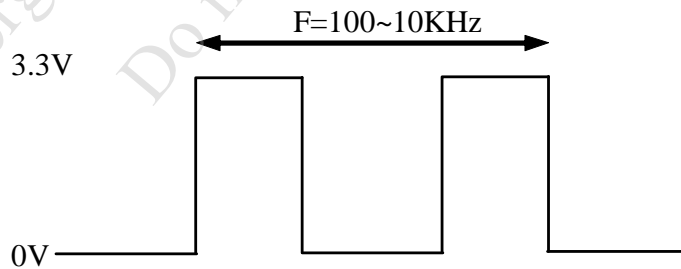

12. INSPECTION CRITERIA

12.1 APPLICATION

THIS INSPECTION STANDARD IS TO BE APPLIED TO THE LCD MODULE DELIVERED FROM EMERGING DISPLAY TECHNOLOGIES CORP.( E.D.T ) TO CUSTOMERS

12.2 INSPECTION CONDITIONS

12.2.1 (1)OBSERVATION DISTANCE : 45±5cm

(2)VIEWING ANGLE : ±45°

±45° (FOR SECTION WITHIN VIEWING AREA), REFER TO FIG.A  
90° (FOR SECTION OUTSIDE OF VIEWING AREA), REF TO FIG.B  
PERPENDICULAR TO MODULE SURFACE

VIEWING ANGLE SHOULD BE SMALLER THAN 45°

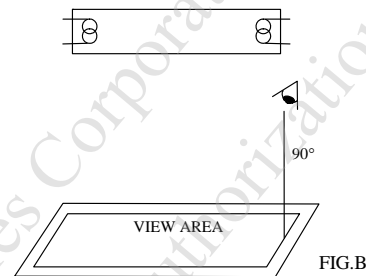
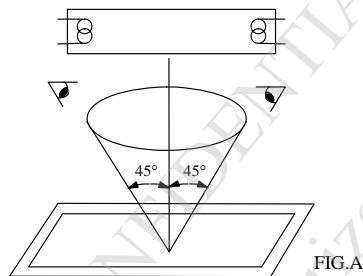

THE INSPECTION CRITERIA IS ACCORDING TO LINE OF SIGHT. INSPECTION SHALL BE MADE WITHIN THE HALF SECTION OF THE VIEWING CONE GENERATED BY LINE SEGMENT OF 45° WITH RESPECT TO THE VERTICAL AXIS FROM CENTER VERTEX OF LCD, THE FLUORESCENT LAMP AND THE CONE AXIS MUST BE PERPENDICULAR TO THE LCD SURFACE.

IF THE DEFECTS ARE OUTSIDE OF VIEWING AREA, IT SHALL BE INSPECTED BY 90° WITH RESPECT TO THE VERTICAL AXIS FROM EDGE OF VIEWING AREA.

12.2.2 ENVIRONMENT CONDITIONS :

AMBIENT TEMPERATURE		25±5°C
AMBIENT HUMIDITY		65 ± 20%RH
AMBIENT ILLUMINATION	COSMETIC INSPECTION	600~800 lux
	FUNCTIONAL INSPECTION	300~500 lux
INSPECTION TIME		15 secs

12.2.3 INSPECTION LOT

QUANTITY PER DELIVERY LOT FOR EACH MODEL

12.2.4 INSPECTION METHOD

A SAMPLING INSPECTION SHALL BE MADE ACCORDING TO THE FOLLOWING PROVISIONS TO JUDGE THE ACCEPTABILITY

(a)APPLICABLE STANDARD :

ANSI/ ASQ Z1.4 NORMAL INSPECTION LEVEL II

(b)AQL : MAJOR DEFECT : AQL 0.65

MINOR DEFECT : AQL 1.0

12.3 INSPECTION STANDARDS

12.3.1 VISUAL DEFECTS CLASSIFICATION

TYPE OF DEFECT	INSPECTION ITEM	DEFECT FEATURE	AQL
MAJOR DEFECT	1.DISPLAY ON	<ul style="list-style-type: none"> <li>• DEFECT TO MISS SPECIFIED DISPLAY FUNCTION, FOR ALL AND SPECIFIED DOTS</li> <li>EX: DISCONNECTION, SHORT CIRCUIT ETC</li> </ul>	0.65
	2.BACKLIGHT	<ul style="list-style-type: none"> <li>• NO LIGHT</li> <li>• FLICKERING AND OTHER ABNORMAL ILLUMINATION</li> </ul>	
	3.DIMENSIONS	<ul style="list-style-type: none"> <li>• SUBJECT TO INDIVIDUAL ACCEPTANCE SPECIFICATIONS</li> </ul>	
MINOR DEFECT	1.DISPLAY ZONE	<ul style="list-style-type: none"> <li>• BLACK/WHITE SPOT</li> <li>• BUBBLES ON POLARIZER</li> <li>• NEWTON RING</li> <li>• BLACK/WHITE LINE</li> <li>• SCRATCH</li> <li>• CONTAMINATION</li> <li>• LEVER COLOR SPREAD</li> </ul>	1.0
	2.BEZEL ZONE	<ul style="list-style-type: none"> <li>• STAINS</li> <li>• SCRATCHES</li> <li>• FOREIGN MATTER</li> </ul>	
	3.SOLDERING	<ul style="list-style-type: none"> <li>• INSUFFICIENT SOLDER</li> <li>• SOLDERED IN INCORRECT POSITION</li> <li>• CONVEX SOLDERING SPOT</li> <li>• SOLDER BALLS</li> <li>• SOLDER SCRAPS</li> </ul>	
	4.DISPLAY ON (ALL ON)	<ul style="list-style-type: none"> <li>• LIGHT LINE</li> </ul>	

12.3.2 MODULE DEFECTS CLASSIFICATION

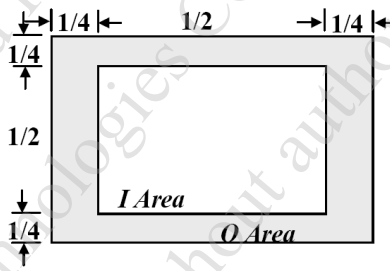
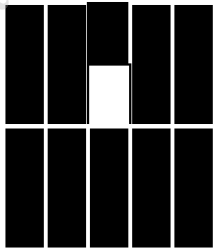
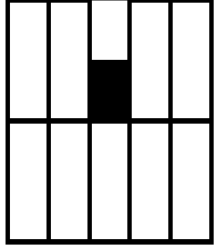
NO.	ITEM	CRITERIA																																	
1	DISPLAY ON INSPECTION	(1)INCORRECT PATTERN (2)MISSING SEGMENT (3)DIM SEGMENT (4)OPERATING VOLTAGE BEYOND SPEC																																	
2	OVERALL DIMENSIONS	OVERALL DIMENSION BEYOND SPEC																																	
		<table border="1"> <thead> <tr> <th>DEFECT TYPE</th> <th colspan="2">CRITERIA</th> </tr> </thead> <tbody> <tr> <td>AREA (NOTE 1)</td> <td>I</td> <td>O</td> </tr> <tr> <td>BRIGHT DOTS (NOTE 2)</td> <td><math>N \leq 0</math></td> <td><math>N \leq 1</math></td> </tr> <tr> <td>DARK DOTS (NOTE 3)</td> <td><math>N \leq 2</math></td> <td><math>N \leq 2</math></td> </tr> <tr> <td>BRIGHT DOT- 2 ADJACENT (NOTE 4)</td> <td colspan="2"><math>N \leq 0</math></td> </tr> <tr> <td>DARK DOTS- 2 ADJACENT (NOTE 5)</td> <td colspan="2"><math>N \leq 0</math></td> </tr> <tr> <td>DARK OR BRIGHT DOTS- 3 AND MORE ADJACENT(NOTE 5)</td> <td colspan="2"><math>N \leq 0</math></td> </tr> <tr> <td>TOTAL BRIGHT AND DARK DOTS (NOTE6)</td> <td colspan="2"><math>N \leq 3</math></td> </tr> <tr> <td>MINIMUM DISTANCE BETWEEN BRIGHT DOTS (NOTE7)</td> <td colspan="2">5 mm</td> </tr> <tr> <td>MINIMUM DISTANCE BETWEEN DARK DOTS (NOTE7)</td> <td colspan="2">5 mm</td> </tr> <tr> <td>MINIMUM DISTANCE BETWEEN DARK AND BRIGHT DOTS (NOTE7)</td> <td colspan="2">5 mm</td> </tr> </tbody> </table>	DEFECT TYPE	CRITERIA		AREA (NOTE 1)	I	O	BRIGHT DOTS (NOTE 2)	$N \leq 0$	$N \leq 1$	DARK DOTS (NOTE 3)	$N \leq 2$	$N \leq 2$	BRIGHT DOT- 2 ADJACENT (NOTE 4)	$N \leq 0$		DARK DOTS- 2 ADJACENT (NOTE 5)	$N \leq 0$		DARK OR BRIGHT DOTS- 3 AND MORE ADJACENT(NOTE 5)	$N \leq 0$		TOTAL BRIGHT AND DARK DOTS (NOTE6)	$N \leq 3$		MINIMUM DISTANCE BETWEEN BRIGHT DOTS (NOTE7)	5 mm		MINIMUM DISTANCE BETWEEN DARK DOTS (NOTE7)	5 mm		MINIMUM DISTANCE BETWEEN DARK AND BRIGHT DOTS (NOTE7)	5 mm	
		DEFECT TYPE	CRITERIA																																
		AREA (NOTE 1)	I	O																															
		BRIGHT DOTS (NOTE 2)	$N \leq 0$	$N \leq 1$																															
		DARK DOTS (NOTE 3)	$N \leq 2$	$N \leq 2$																															
		BRIGHT DOT- 2 ADJACENT (NOTE 4)	$N \leq 0$																																
		DARK DOTS- 2 ADJACENT (NOTE 5)	$N \leq 0$																																
		DARK OR BRIGHT DOTS- 3 AND MORE ADJACENT(NOTE 5)	$N \leq 0$																																
		TOTAL BRIGHT AND DARK DOTS (NOTE6)	$N \leq 3$																																
		MINIMUM DISTANCE BETWEEN BRIGHT DOTS (NOTE7)	5 mm																																
MINIMUM DISTANCE BETWEEN DARK DOTS (NOTE7)	5 mm																																		
MINIMUM DISTANCE BETWEEN DARK AND BRIGHT DOTS (NOTE7)	5 mm																																		
NOTE :																																			
1. DEFINITION OF AREA																																			
																																			
3	ELECTRICAL DEFECT	<p>2. BRIGHT DOT DEFECT DEFINITION BRIGHT AREA IS MORE THAN 50% OF ONE DOT .ALL BRIGHT DOT DEFECT MUST BE VISIBLE THROUGH 5% ND FILTER.</p>  <p>3. DARK DOT DEFECT DEFINITION DARK AREA IS MORE THAN 50% OF ONE DOT. ALL BRIGHT DOT DEFECT MUST BE VISIBLE THROUGH 5% ND FILTER.</p> 																																	

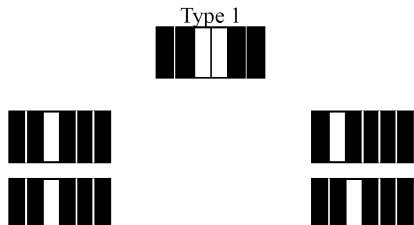
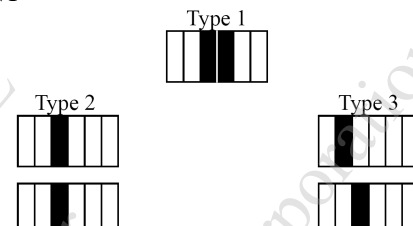
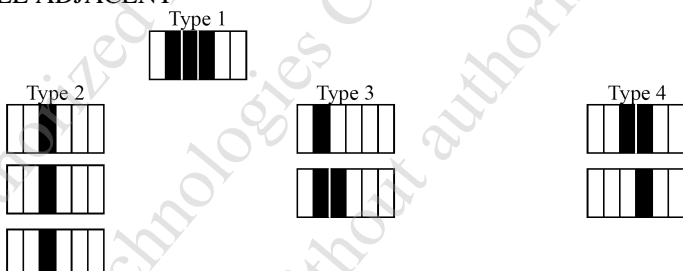
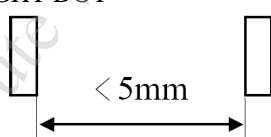
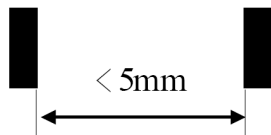
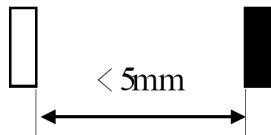
NO.	ITEM	CRITERIA
3	ELECTRICAL DEFECT	<p>4. BRIGHT DOT DEFECT DESCRIPTION TWO ADJACENT</p>  <p>5. DARK DOT DEFECT DESCRIPTION TWO ADJACENT</p>  <p>6. DARK DOT DEFECT DESCRIPTION THREE ADJACENT</p>  <p>7. MINIMUM DISTANCE BETWEEN DOT DEFECTS BRIGHT DOT TO BRIGHT DOT</p>  <p>NG</p> <p>DARK DOT TO DARK DOT</p>  <p>NG</p> <p>BRIGHT DOT TO DARK DOT</p>  <p>NG</p>

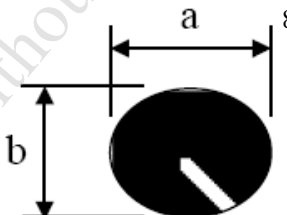
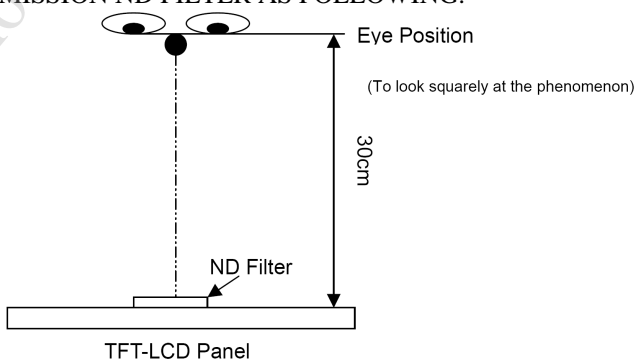
NO.	ITEM	CRITERIA		
		DEFECT TYPE	CRITERIA	
4	VISUAL DEFECT	FOREIGN MATERIAL	CIRCULAR FOREIGN MATERIAL : DARK/ BRIGHT SPOT	VISIBLE UNDER : ND5% 1.D≤0.15mm : NO COUNT 2.0.15mm<D≤0.5mm, N≤4 3.D>0.5mm : NOT ALLOWABLE
			LINEAR FOREIGN MATERIAL : BRIGHT OR DARK LINE	INVISIBLE UNDER ND5% 0.1mm<W≤0.5mm, 0.3mm<L≤1.5mm,N≤4 VISIBLE UNDER ND5% 0.05mm≤W≤0.1mm, 0.3mm≤L≤0.7mm,N≤4
		POLARIZER	LINEAR SCRATCH	1. BM: NO COUNT 2. PIXEL AREA 0.05mm≤W≤0.2mm, 1.0mm≤L≤5.0mm,N≤4
			BUBBLE/ PEELING	1. BM: NO COUNT 2. PIXEL AREA 0.15mm≤D<0.5mm,N≤4
		MURA & LEAK	ND5%	
<p>NOTE :</p> <p>1. a. EVERY DOT HEREIN MEANS SUB-PIXEL (EACH RED, GREEN, BLUE COLOR).  b. DAMAGED LESS THAN HALF SIZE OF SUB-PIXEL IS NOT COUNTED AS DEFECT.  c. EXTRANEIOUS SUBSTANCES WHICH CAN BE WIPED OUT ARE NOT CONSIDERED AS DEFECT.  d. DEFECTS WHICH IS ON THE BLACK MATRIX (OUTSIDE OF ACTIVE AREA ) ARE NOT CONSIDERED AS DEFECT.</p> <p>2. "AVERAGE DIAMETER" DESCRIPTION  AVERAGE DIAMETER=(a+b)/2</p>  <p>THE DEFECT THAT ARE NOT DEFINED ABOVE AND CONSIDERED TO BE PROBLEM SHALL BE REVIEWED AND DISCUSSED BY BOTH PARTIES.</p> <p>3. BRIGHT DOT, MURA AND LEAK ARE DEFINED THROUGH TRANSMISSION ND FILTER AS FOLLOWING.</p>  <p>4. IT DOESN'T MATTER WHETHER SILICON OR EGC IS USED FOR FRAME SPREAD, THIS PRODUCT IS ALWAYS RELIABLE.</p>				

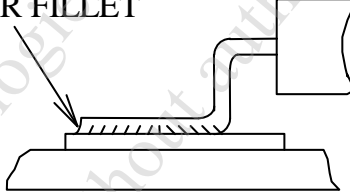
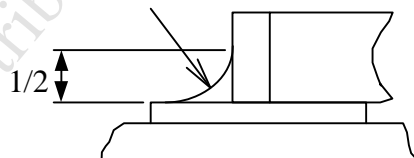
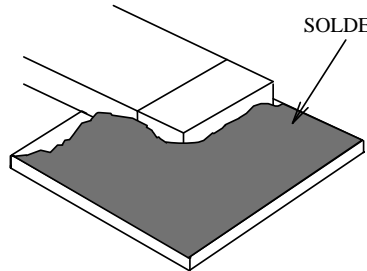
NO.	ITEM	CRITERIA
5	UNEVEN COLOR SPREAD, COLORATION	(1)TO BE DETERMINED BASED UPON THE STANDARD SAMPLE.
6	BEZEL APPEARANCE	(1)BEZEL MAY NOT HAVE RUST, BE DEFORMED OR HAVE FINGER PRINTS STAINS OF OTHER CONTAMINATION. (2)BEZEL MUST COMPLY WITH JOB SPECIFICATIONS.
7	PCB	(1)THERE MAY NOT BE MORE THAN 2mm OF SEALANT OUTSIDE THE SEAL AREA ON THE PCB, AND THERE SHOULD BE NO MORE THAN THREE PLACES. (2)NO OXIDATION OR CONTAMINATION PCB TERMINALS. (3)PARTS ON PCB MUST BE THE SAME AS ON THE PRODUCTION CHARACTERISTIC CHART. THERE SHOULD BE NO WRONG PARTS, MISSING PARTS OR EXCESS PARTS. (4)THE JUMPER ON THE PCB SHOULD CONFORM TO THE PRODUCT CHARACTERISTIC CHART. (5)IF SOLDER GETS ON BEZEL TAB PADS, LED PAD, ZEBRA PAD OR SCREW HOLD PAD, MAKE SURE IT IS SMOOTHED DOWN.
8	SOLDERING	<p>(1)NO SOLDERING FOUND ON THE SPECIFIED PLACE</p> <p>(2)INSUFFICIENT SOLDER</p> <p>(a)LSI, IC A POOR WETTING OF SOLDER IS BETWEEN LOWER BEND OR "HEEL" OF LEAD AND PAD</p> <p style="text-align: center;">SOLDER FILLET</p>  <p>(b)CHIP COMPONENT · SOLDER IS LESS THAN 50% OF SIDES AND FRONT FACE WETTING</p> <p style="text-align: center;">SOLDER FILLET</p>  <p>· SOLDER WETS 3 SIDES OF TERMINAL, BUT LESS THAN 25% OF SIDES AND FRONT SURFACE AREA ARE COVERED</p> 

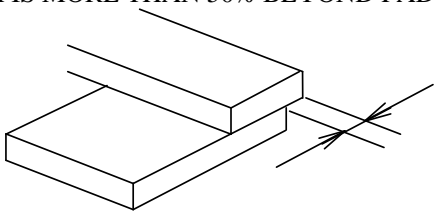
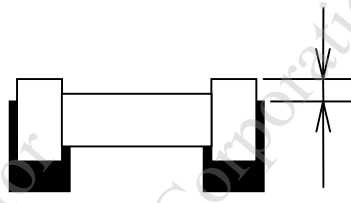
NO.	ITEM	CRITERIA
8	SOLDERING	<p>(3)PARTS ALIGNMENT (a)LSI, IC LEAD WIDTH IS MORE THAN 50% BEYOND PAD OUTLINE</p>  <p>(b)CHIP COMPONENT COMPONENT IS OFF CENTER, AND MORE THAN 50% OF THE LEADS IS OFF THE PAD OUTLINE</p>  <p>(4)NO UNMELTED SOLDER PASTE MAY BE PRESENT ON THE PCB. (5)NO COLD SOLDER JOINTS, MISSING SOLDER CONNECTIONS, OXIDATION OR ICICLE. (6)NO RESIDUE OR SOLDER BALLS ON PCB. (7)NO SHORT CIRCUITS IN COMPONENTS ON PCB.</p>
9	BACKLIGHT	<p>(1)NO LIGHT (2)FLICKERING AND OTHER ABNORMAL ILLUMINATION (3)SPOTS OR SCRATCHES THAT APPEAR WHEN LIT MUST BE JUDGED USING LCD SPOT, LINES AND CONTAMINATION STANDARDS. (4)BACKLIGHT DOESN'T LIGHT OR COLOR IS WRONG.</p>
10	GENERAL APPEARANCE	<p>(1)NO OXIDATION, CONTAMINATION, CURVES OR, BENDS ON INTERFACE PIN (OLB) OF TCP. (2)NO CRACKS ON INTERFACE PIN (OLB) OF TCP. (3)NO CONTAMINATION, SOLDER RESIDUE OR SOLDER BALLS ON PRODUCT. (4)THE IC ON THE TCP MAY NOT BE DAMAGED, CIRCUITS. (5)THE UPPERMOST EDGE OF THE PROTECTIVE STRIP ON THE INTERFACE PIN MUST BE PRESENT OR LOOK AS IF IT CAUSE THE INTERFACE PIN TO SEVER. (6)THE RESIDUAL ROSIN OR TIN OIL OF SOLDERING (COMPONENT OR CHIP COMPONENT) IS NOT BURNED INTO BROWN OR BLACK COLOR. (7)SEALANT ON TOP OF THE ITO CIRCUIT HAS NOT HARDENED. (8)PIN TYPE MUST MATCH TYPE IN SPECIFICATION SHEET. (9)LCD PIN LOOSE OR MISSING PINS. (10)PRODUCT PACKAGING MUST THE SAME AS SPECIFIED ON PACKAGING SPECIFICATION SHEET. (11)PRODUCT DIMENSION AND STRUCTURE MUST CONFORM TO PRODUCT SPECIFICATION SHEET. (12)THE APPEARANCE OF HEAT SEAL SHOULD NOT ADMIT ANY DIRT AND BREAK.</p>

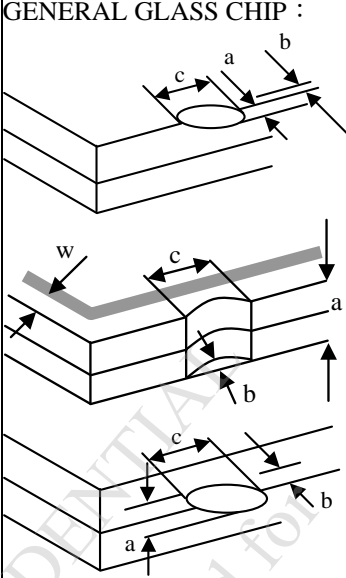
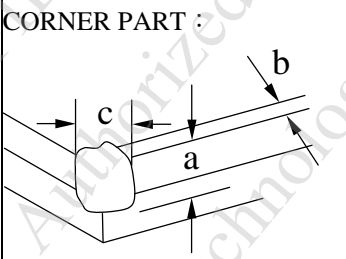
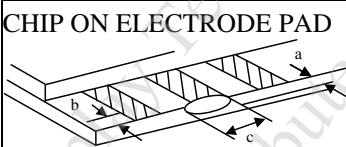
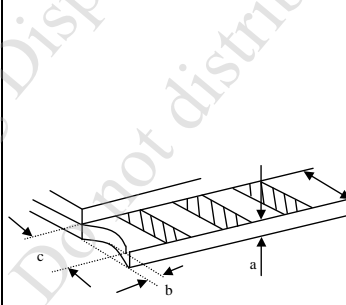
NO.	ITEM	CRITERIA									
11	CRACKED GLASS	<p>THE LCD WITH EXTENSIVE CRACK IS NOT ACCEPTABLE</p> <p>GENERAL GLASS CHIP :</p>  <table border="1"> <thead> <tr> <th>a</th> <th>b</th> <th>c</th> </tr> </thead> <tbody> <tr> <td><math>\leq t/2</math></td> <td>&lt; VIEWING AREA</td> <td><math>\leq 1/8X</math></td> </tr> <tr> <td><math>t/2 &gt; , \leq 2t</math></td> <td><math>\leq W/2</math></td> <td><math>\leq 1/8X</math></td> </tr> </tbody> </table> <p>*W=DISTANCE BETWEEN SEALANT AREA AND LCD PANEL EDGE X = LCD SIDE LENGTH t = GLASS THICKNESS</p>	a	b	c	$\leq t/2$	< VIEWING AREA	$\leq 1/8X$	$t/2 > , \leq 2t$	$\leq W/2$	$\leq 1/8X$
		a	b	c							
		$\leq t/2$	< VIEWING AREA	$\leq 1/8X$							
		$t/2 > , \leq 2t$	$\leq W/2$	$\leq 1/8X$							
<p>CORNER PART :</p>  <table border="1"> <thead> <tr> <th>a</th> <th>b</th> <th>c</th> </tr> </thead> <tbody> <tr> <td><math>\leq t/2</math></td> <td>&lt; VIEWING AREA</td> <td><math>\leq 1/8X</math></td> </tr> <tr> <td><math>&gt; t/2 , \leq 2t</math></td> <td><math>\leq W/2</math></td> <td><math>\leq 1/8X</math></td> </tr> </tbody> </table> <p>*W=DISTANCE BETWEEN SEALANT AREA AND LCD PANEL EDGE X = LCD SIDE LENGTH t = GLASS THICKNESS</p>	a	b	c	$\leq t/2$	< VIEWING AREA	$\leq 1/8X$	$> t/2 , \leq 2t$	$\leq W/2$	$\leq 1/8X$		
a	b	c									
$\leq t/2$	< VIEWING AREA	$\leq 1/8X$									
$> t/2 , \leq 2t$	$\leq W/2$	$\leq 1/8X$									
<p>CHIP ON ELECTRODE PAD</p>  <table border="1"> <thead> <tr> <th>a</th> <th>b</th> <th>c</th> </tr> </thead> <tbody> <tr> <td><math>\leq t</math></td> <td><math>\leq 0.5\text{mm}</math></td> <td><math>\leq 1/8X</math></td> </tr> </tbody> </table> <p>*X=LCD SIDE WIDTH t=GLASS THICKNESS</p>	a	b	c	$\leq t$	$\leq 0.5\text{mm}$	$\leq 1/8X$					
a	b	c									
$\leq t$	$\leq 0.5\text{mm}$	$\leq 1/8X$									
 <table border="1"> <thead> <tr> <th>a</th> <th>b</th> <th>c</th> </tr> </thead> <tbody> <tr> <td><math>\leq t</math></td> <td><math>\leq 1/8X</math></td> <td><math>\leq L</math></td> </tr> </tbody> </table> <p>*X=LCD SIDE WIDTH t = GLASS THICKNESS L=ELECTRODE PAD LENGTH</p> <p>①IF GLASS CHIPPING THE ITO TERMINAL, OVER 2/3 OF THE ITO MUST REMAIN AND BE, INSPECTED ACCORDING TO ELECTRODE TERMINAL SPECIFICATIONS</p> <p>②IF THE PRODUCT WILL BE HEAT SEALED BY THE CUSTOMER, THE ALIGNMENT MARK MUST NOT BE DAMAGED</p>	a	b	c	$\leq t$	$\leq 1/8X$	$\leq L$					
a	b	c									
$\leq t$	$\leq 1/8X$	$\leq L$									

12.4 RELIABILITY TEST

12.4.1 STANDARD SPECIFICATIONS FOR RELIABILITY OF LCD MODULE

NO.	ITEM	DESCRIPTION
1	HIGH TEMPERATURE OPERATION	THE SAMPLE SHOULD BE ALLOWED TO STAND AT +70°C FOR 168 HRS
2	LOW TEMPERATURE OPERATION	THE SAMPLE SHOULD BE ALLOWED TO STAND AT -20°C FOR 168 HRS
3	HIGH TEMPERATURE STORAGE	THE SAMPLE SHOULD BE ALLOWED TO STAND AT +80°C FOR 168 HRS
4	LOW TEMPERATURE STORAGE	THE SAMPLE SHOULD BE ALLOWED TO STAND AT -30°C FOR 168 HRS
5	HIGH TEMPERATURE /HUMIDITY TEST (STORAGE)	THE SAMPLE SHOULD BE ALLOWED TO STAND AT 50°C, 85% RH 168 HRS
6	THERMAL SHOCK (NOT OPERATED)	<p>THE SAMPLE SHOULD BE ALLOWED TO STAND THE FOLLOWING 1 CYCLES OF OPERATION :</p>
7	ESD (ELECTROSTATIC DISCHARGE) (NOT OPERATED)	<p>AIR DISCHARGE ± 8KV CONTACT DISCHARGE ± 4KV ACCORDING TO IEC-61000-4-2</p>

NOTE ( 1 ) : THE TEST SAMPLES HAVE RECOVERY TIME FOR 2 HOURS AT ROOM TEMPERATURE BEFORE THE FUNCTION CHECK. IN THE STANDARD CONDITIONS, THERE IS NO DISPLAY FUNCTION NG ISSUE OCCURRED.

12.5 TESTING CONDITIONS AND INSPECTION CRITERIA

FOR THE FINAL TEST THE TESTING SAMPLE MUST BE STORED AT ROOM TEMPERATURE FOR 24 HOURS, AFTER THE TESTS LISTED IN TABLE 12.5, STANDARD SPECIFICATIONS FOR RELIABILITY HAVE BEEN EXECUTED IN ORDER TO ENSURE STABILITY.

NO.	ITEM	TEST MODEL	INSPECTION CRITERIA
1	CURRENT CONSUMPTION	REFER TO SPECIFICATION	THE CURRENT CONSUMPTION SHOULD CONFORM TO THE PRODUCT SPECIFICATION.
2	CONTRAST	REFER TO SPECIFICATION	AFTER THE TESTS HAVE BEEN EXECUTED, THE CONTRAST MUST BE LARGER THAN HALF OF ITS INITIAL VALUE PRIOR TO THE TESTS.
3	APPEARANCE	VISUAL INSPECTION	DEFECT FREE

## 12.6 OPERATION

- 12.6.1 DO NOT CONNECT OR DISCONNECT MODULES TO OR FROM THE MAIN SYSTEM WHILE POWER IS BEING SUPPLIED .
- 12.6.2 USE THE MODULE WITHIN SPECIFIED TEMPERATURE ; LOWER TEMPERATURE CAUSES THE RETARDATION OF BLINKING SPEED OF THE DISPLAY ; HIGHER TEMPERATURE MAKES OVERALL DISPLAY DISCOLOR. WHEN THE TEMPERATURE RETURNS TO NORMALITY, THE DISPLAY WILL OPERATE NORMALLY .
- 12.6.3 ADJUST THE LC DRIVING VOLTAGE TO OBTAIN THE OPTIMUM CONTRAST.
- 12.6.4 POWER ON SEQUENCE INPUT SIGNALS SHOULD NOT BE SUPPLIED TO LCD MODULE BEFORE POWER SUPPLY VOLTAGE IS APPLIED AND REACHES THE SPECIFIED VALUE .  
IF ABOVE SEQUENCE IS NOT FOLLOWED , CMOS LSIS OF LCD MODULES MAY BE DAMAGED DUE TO LATCH - UP PROBLEM .
- 12.6.5 NOT ALLOWED TO INFLICT ANY EXTERNAL STRESS AND TO CAUSE ANY MECHANICAL INTERFERENCE ON THE BENDING AREA OF FPC DURING THE TAIL BENDING BACKWARDS!  
DO NOT STRESS FPC AND IC ON THE MODULE!

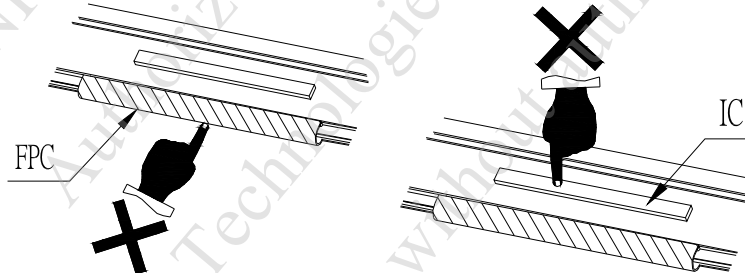

## 12.7 NOTICE

- 12.7.1 USE A GROUNDED SOLDERING IRON WHEN SOLDERING CONNECTOR I/O TERMINALS . FOR SOLDERING OR REPAIRING, TAKE PRECAUTION AGAINST THE TEMPERATURE OF THE SOLDERING IRON AND THE SOLDERING TIME TO PREVENT PEELING OFF THE THROUGH-HOLE-PAD .
- 12.7.2 DO NOT DISASSEMBLE . EDT SHALL NOT BE HELD RESPONSIBLE IF THE MODULE IS DISASSEMBLED AND UPON THE REASSEMBLY THE MODULE FAILED .
- 12.7.3 DO NOT CHARGE STATIC ELECTRICITY , AS THE CIRCUIT OF THIS MODULE CONTAINS CMOS LSIS. A WORKMAN'S BODY SHOULD ALWAYS BE STATIC-PROTECTED BY USE OF AN ESD STRAP. WORKING CLOTHES FOR SUCH PERSONNEL SHOULD BE OF STATIC-PROTECTED MATERIAL .
- 12.7.4 ALWAYS GROUND THE ELECTRICALLY-POWERED DRIVER BEFORE USING IT TO INSTALL THE LCD MODULE. WHILE CLEANING THE WORK STATION BY VACUUM CLEANER, DO NOT BRING THE SUCKING MOUTH NEAR THE MODULE ; STATIC ELECTRICITY OF THE ELECTRICALLY-POWERED DRIVER OR THE VACUUM CLEANER MAY DESTROY THE MODULE .
- 12.7.5 DON'T GIVE EXTERNAL SHOCK.
- 12.7.6 DON'T APPLY EXCESSIVE FORCE ON THE SURFACE.
- 12.7.7 LIQUID IN LCD IS HAZARDOUS SUBSTANCE. MUST NOT LICK AND SWALLOW.  
WHEN THE LIQUID IS ATTACH TO YOUR, SKIN, CLOTH ETC.  
WASH IT OUT THOROUGHLY AND IMMEDIATELY.
- 12.7.8 DON'T OPERATE IT ABOVE THE ABSOLUTE MAXIMUM RATING.
- 12.7.9 STORAGE IN A CLEAN ENVIRONMENT, FREE FROM DUST, ACTIVE GAS, AND SOLVENT.
- 12.7.10 STORE WITHOUT ANY PHYSICAL LOAD.
- 12.7.11 REWIRING: NO MORE THAN 3 TIMES.