

EXAMINED BY :	EMERGING DISPLAY TECHNOLOGIES CORPORATION	FILE NO . CAS-0008670
Lucica Lu		ISSUE : MAR.11, 2025
APPROVED BY:		TOTAL PAGE : 31
Vincent Wu		VERSION : 4

CUSTOMER ACCEPTANCE SPECIFICATIONS

MODEL NO. :

ET0430G8DH6

(RoHS)

FOR MESSRS :

CUSTOMER'S APPROVAL

DATE :

BY :

RECORDS OF REVISION		DOC . FIRST ISSUE	JUN.26, 2018
DATE	REVISED PAGE NO.	SUMMARY	
SEP.03, 2018	3	4. ELECTRICAL CHARACTERISTICS POWER SUPPLY CURRENT: TYP.=15→20, MAX.=20→35	
SEP.05, 2024	1	1.1 DATA SHEETS FOR CONTROLLER/DRIVER PLEASE REFER TO: SITRONIX ST7282→SITRONIX ST7282A	
	3	4. ELECTRICAL CHARACTERISTICS PARAMETER:POWER SUPPLY VOLTAGE FOR LED DRIVER, MIN.: 2.7→2.8	
	11	8. BLOCK DIAGRAM IC:ST7282→ST7282A	
MAR.11, 2025	15	<p>11.1 POWER SUPPLY FOR LCM</p> <p>11.2 THE BRIGHTNESS CONTROLLED BY BACKLIGHT CURRENT OF LEDCTRL TBD→</p> <p>NOTE : LEDCTRL 0~2.5±0.15V</p>	

TABLE OF CONTENTS

NO.	ITEM	PAGE
1.	GENERAL SPECIFICATIONS -----	1
2.	MECHANICAL SPECIFICATIONS -----	1
3.	ABSOLUTE MAXIMUM RATINGS -----	2
4.	ELECTRICAL CHARACTERISTICS -----	3
5.	TIMING CHARACTERISTICS -----	4 ~ 7
6.	OPTICAL CHARACTERISTICS -----	8, 9
7.	OUTLINE DIMENSIONS -----	10
8.	BLOCK DIAGRAM -----	11
9.	DETAIL DRAWING OF DOT MATRIX -----	12
10.	INTERFACE SIGNALS -----	13, 14
11.	POWER SUPPLY -----	15
12.	TOUCH PANEL SPECIFICATION -----	16 ~ 21
13.	INSPECTION CRITERION -----	22 ~ 31

CONFIDENTIAL
Authorized for Emerging Display Technologies Corporation Only.
Do not distribute without authorization.

1. GENERAL SPECIFICATIONS

1.1 DATA SHEETS FOR CONTROLLER/DRIVER

PLEASE REFER TO :

SITRONIX ST7282A

1.2 MATERIAL SAFETY DESCRIPTION

ASSEMBLIES SHALL COMPLY WITH EUROPEAN ROHS REQUIREMENTS, INCLUDING PROHIBITED MATERIALS/COMPONENTS CONTAINING LEAD, MERCURY, CADMIUM, HEXAVALENT CHROMIUM, POLYBROMINATED BIPHENYLS (PBB) AND POLYBROMINATED DIPHENYL ETHERS (PBDE)

2. MECHANICAL SPECIFICATIONS

(1) DIAGONALS	-----	4.3 inch
(2) NUMBER OF DOTS	-----	480W * (RGB) * 272H DOTS
(3) MODULE SIZE	-----	105.5W * 67.2H * 9.3D (MAX.) mm (WITHOUT FPC)
(4) VIEWING AREA	-----	98.7W * 56.4H mm
(5) ACTIVE AREA	-----	95.04W * 53.856H mm (LCD) 97W * 55.8H mm (T/P)
(6) DOT SIZE	-----	0.066W * 0.198H mm
(7) PIXEL PITCH	-----	0.198W * 0.198H mm
(8) LCD TYPE	-----	TFT , TRANSMISSIVE
(9) COLOR	-----	262K
(10) VIEWING DIRECTION	-----	6 O'CLOCK (GRAY LEVEL INVERSION)
(11) BACK LIGHT	-----	LED , COLOR : WHITE
(12) INTERFACE MODE	-----	RGB 18 BIT PARALLEL

3. ABSOLUTE MAXIMUM RATINGS

3.1 ELECTRICAL ABSOLUTE MAXIMUM RATINGS

PARAMETER	SYMBOL	MIN.	MAX.	UNIT	REMARK
POWER VOLTAGE	VCC-VSS	-0.3	4.0	V	
STATIC ELECTRICITY	—	—	—	V	NOTE (1)
LED BACKLIGHT POWER DISSIPATION	PO	—	1020	mW	
LED BACKLIGHT FORWARD CURRENT	IF	—	50	mA	

NOTE (1) : LCM SHOULD BE GROUNDED DURING HANDLING LCM.

3.2 ENVIRONMENTAL ABSOLUTE MAXIMUM RATINGS

ITEM	OPERATING		STORAGE		REMARK
	MIN.	MAX.	MIN.	MAX.	
AMBIENT TEMPERATURE	-20°C	70°C	-30°C	80°C	NOTE (1), (2)
HUMIDITY	NOTE (3)		NOTE (3)		WITHOUT CONDENSATION
VIBRATION	—	3.92 m/s ² (0.4 G)	—	19.6 m/s ² (2.0 G)	10~55Hz X, Y, Z, EACH 2HRS
SHOCK	—	58.8 m/s ² (6 G)	—	980 m/s ² (100 G)	6 ms XYZ DIRECTIONS 3 TIMES EACH
CORROSIVE GAS	NOT ACCEPTABLE		NOT ACCEPTABLE		

NOTE (1) : Ta AT -30°C : WILL BE 48HRS MAX.
80°C : WILL BE 168HRS MAX.

NOTE (2) : BACKGROUND COLOR CHANGES SLIGHTLY DEPENDING ON AMBIENT
TEMPERATURE THIS PHENOMENON IS REVERSIBLE.

NOTE (3) : Ta ≤ 60°C : 90%RH MAX (96HRS MAX).

Ta > 60°C : ABSOLUTE HUMIDITY MUST BE LOWER THAN THE HUMIDITY
OF 90%RH AT 60°C (96HRS MAX).

4. ELECTRICAL CHARACTERISTICS

Ta = 25 °C

PARAMETER	SYMBOL	CONDITION	MIN.	TYP.	MAX.	UNIT	REMARK
POWER SUPPLY VOLTAGE	VDD-VSS	—	3.0	3.3	3.6	V	
POWER SUPPLY VOLTAGE FOR LED DRIVER	VCC-VSS	—	2.8	3.3	5.5	V	
LOGIC HIGH INPUT VOLTAGE	VIH	—	0.7*VDD	—	VDD	V	NOTE (1)
LOGIC LOW INPUT VOLTAGE	VIL	—	0	—	0.3*VDD	V	
POWER SUPPLY CURRENT	IDD	VDD-VSS=3.3V	—	20	35	mA	NOTE (2)
POWER SUPPLY CURRENT FOR LED DRIVER	ICC	VCC-VSS=3.3V LED B/L=ON	—	390	510	mA	
POWER SUPPLY FOR LED BACKLIGHT	VF	IF = 40mA	16.8	19.2	20.4	V	NOTE (3)
LED LIFE TIME	—	I _{LED} =20mA (PER. LED)	30K	—	—	HRS	NOTE (4) NOTE (5)

NOTE (1) : APPLIED TO TERMINALS B5~B0, G5~G0, R5~R0, DCLK, HSYNC, VSYNC, DE.

NOTE (2) : THE DISPLAY PATTERN IS ALL "WHITE".

NOTE (3) : INTERNAL CIRCUIT DIAGRAM OF BACKLIGHT

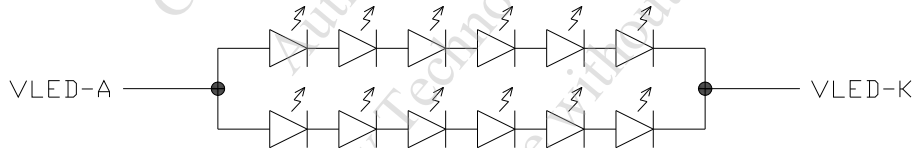

NOTE (4) : CONDITIONS; TA=25 °C, CONTINUOUS LIGHTING

NOTE (5) : DEFINITIONS OF LIFE TIME :

LCM LUMINANCE BECOMES HALF OF THE INITIAL VALUE.

5. TIMING CHARACTERISTICS

5.1 CLOCK AND DATA INPUT TIMING DIAGRAM

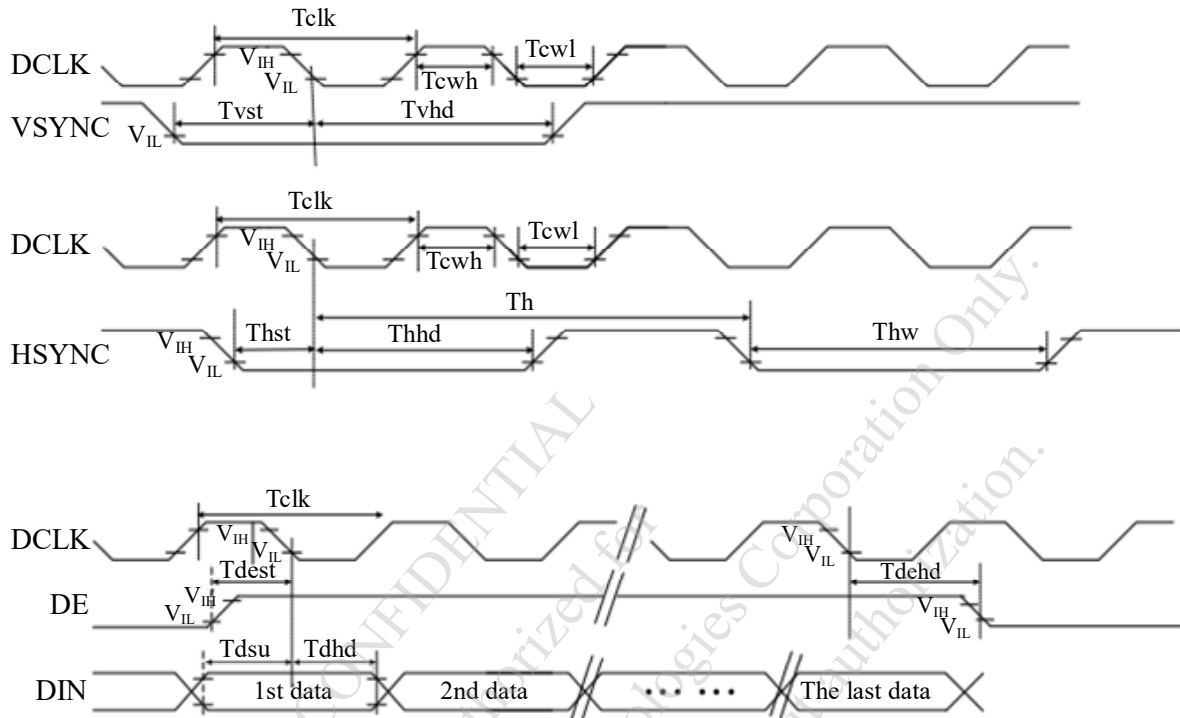

5.2 PARALLEL RGB TIMING TABLE

ITEM	SYMBOL	MIN.	TYP.	MAX.	UNIT	REMARK	
DCLK FREQUENCY	Fclk	8	9	12	MHz		
DCLK PERIOD	Tclk	83	111	125	ns		
HSYNC	PERIOD TIME	Th	485	531	598	DCLK	
	DISPLAY PERIOD	Thdisp	—	480	—	DCLK	
	BACK PORCH	Thbp	3	43	43	DCLK	BY H_BLANKING SETTING
	FRONT PORCH	Thfp	2	8	75	DCLK	
	PULSE WIDTH	Thw	2	4	75	DCLK	
VSYNC	PERIOD TIME	Tv	276	292	321	H	
	DISPLAY PERIOD	Tvdisp	—	272	—	H	
	BACK PORCH	Tvbp	2	12	12	H	BY V_BLANKING SETTING
	FRONT PORCH	Tvfp	2	8	37	H	
	PULSE WIDTH	Tvw	2	4	37	H	

NOTE : IT IS NECESSARY TO KEEP Tvbp= 12 AND Thbp=43 IN SYNC MODE. DE MODE IS UNNECESSARY TO KEEP IT.

5.3 SYNC MODE TIMING DIAGRAM

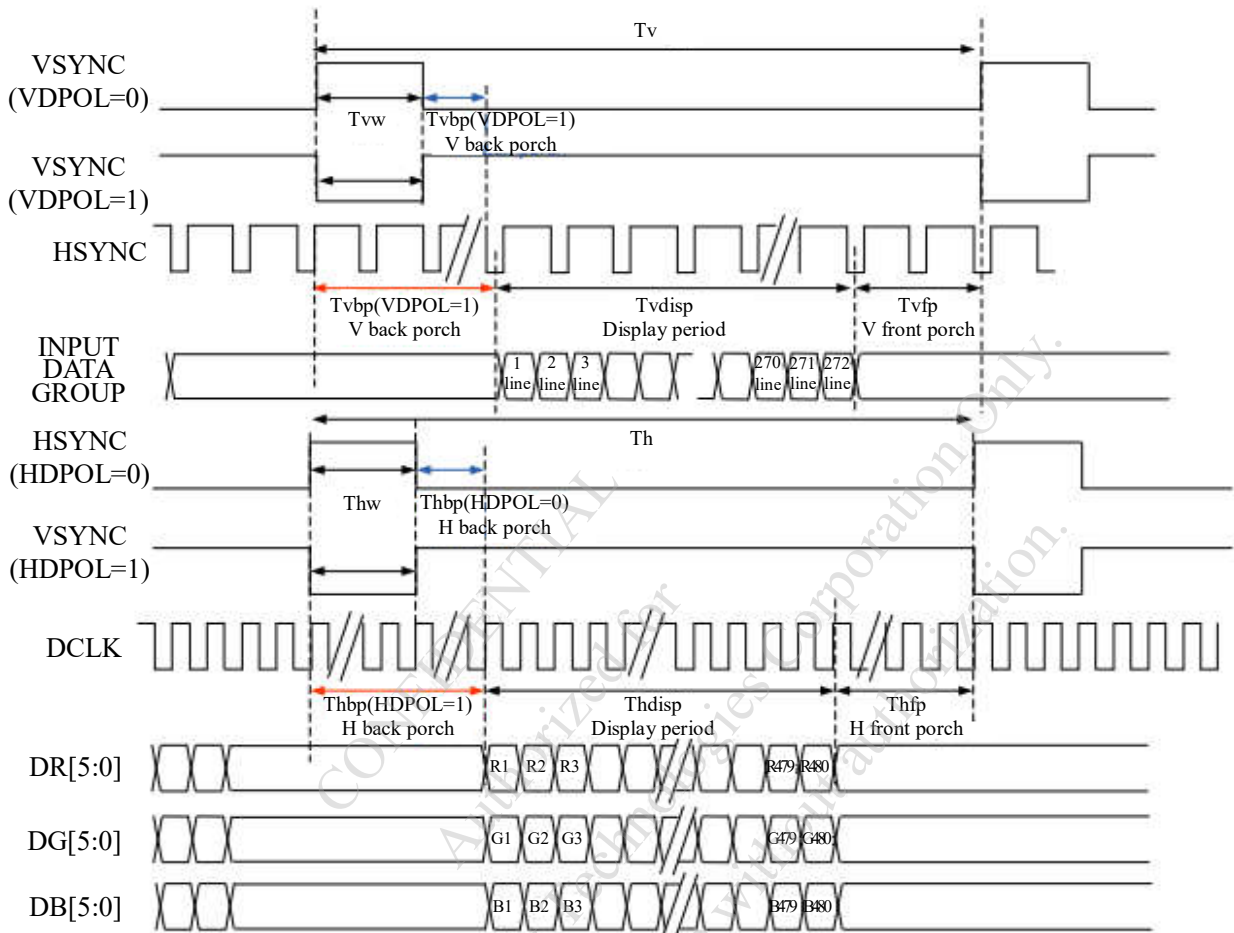

5.4 SYNC-DE MODE TIMING DIAGRAM

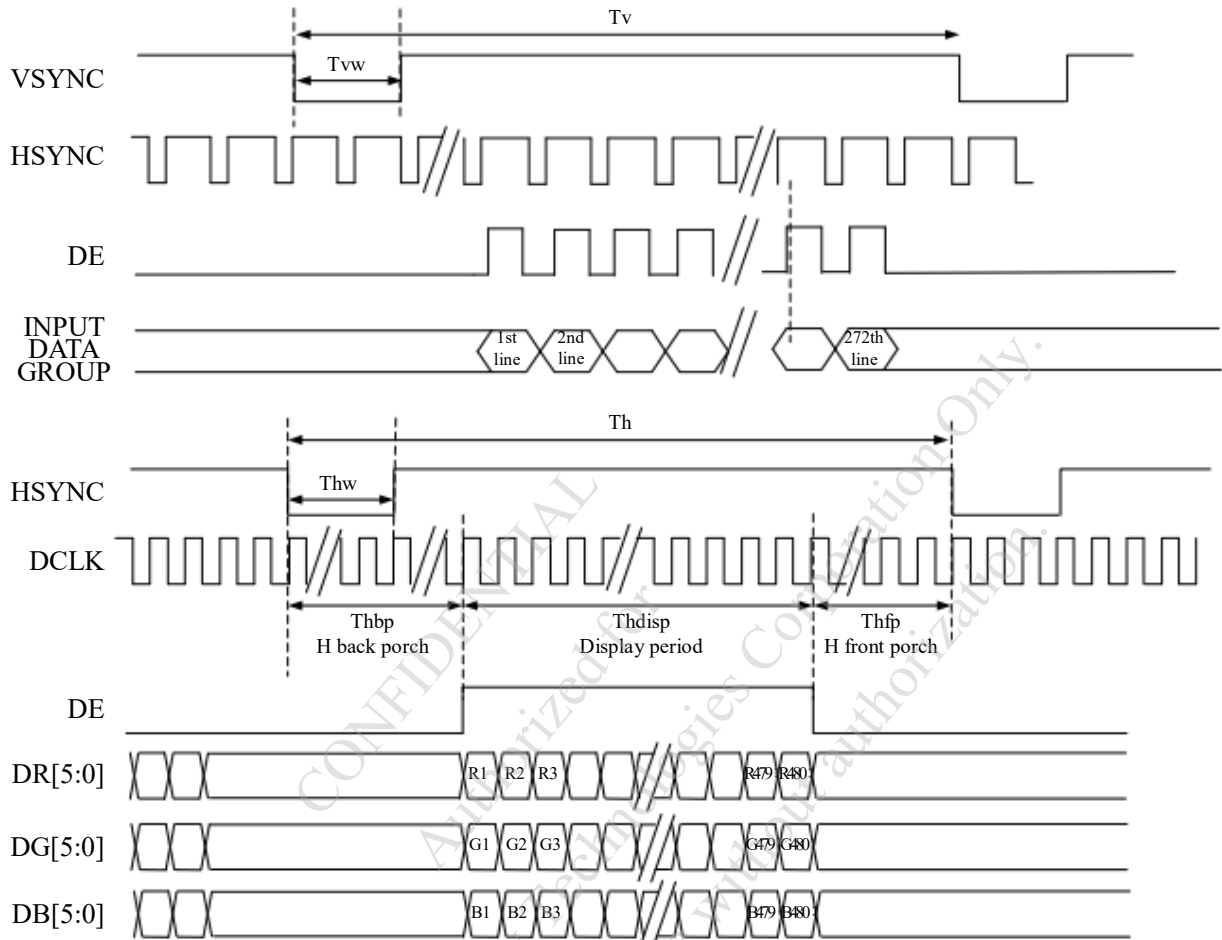

CONFIDENTIAL
 Authorized for Emerging Display Technologies Corporation Only
 Do not distribute without authorization

5.5 DE MODE TIMING DIAGRAM

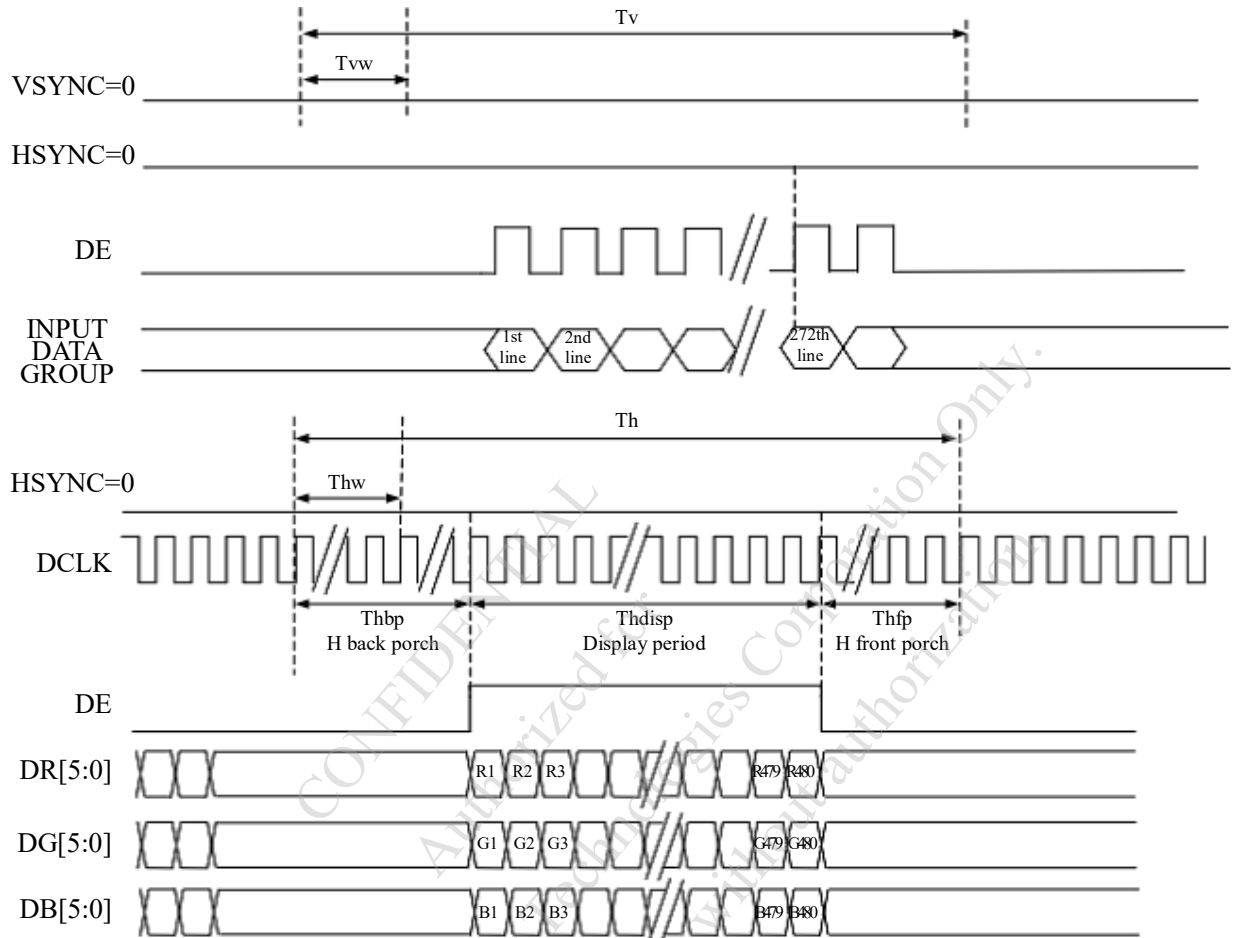

6. OPTICAL CHARACTERISTICS (NOTE 1)

6.1 OPTICAL CHARACTERISTICS

Ta = 25°C

ITEM	SYMBOL	CONDITION	MIN.	TYP.	MAX.	UNIT	REMARK	
VIEWING ANGLE	θ_{y+}	CR ≥ 10	$\theta_x=0^\circ$	50	60	—	deg.	NOTE (2) NOTE (3)
	θ_{y-}			60	70	—		
	θ_{x+}		$\theta_y=0^\circ$	60	70	—		
	θ_{x-}			60	70	—		
CONTRAST RATIO	CR	$\theta_x=0^\circ, \theta_y=0^\circ$	400	600	—	—	NOTE (3)	
RESPONSE TIME	tr (rise) + tf (fall)	$\theta_x=0^\circ, \theta_y=0^\circ$	—	25	40	msec	NOTE (4)	
COLOR OF CIE COORDINATE	WHITE	Wx	$\theta_x=0^\circ, \theta_y=0^\circ$ IF = 40mA NTSC : 50%	0.250	0.300	0.350	—	NOTE (5)
		Wy		0.270	0.320	0.370		
	RED	Rx		0.535	0.586	0.635	—	
		Ry		0.314	0.364	0.414		
	GREEN	Gx		0.283	0.333	0.383	—	
		Gy		0.508	0.558	0.608		
	BLUE	Bx		0.100	0.150	0.200	—	
		By		0.010	0.060	0.110		
THE BRIGHTNESS OF MODULE	B	$\theta_x=0^\circ, \theta_y=0^\circ$ IF = 40mA	360	400	—	cd/m ²	NOTE (6)	
THE BRIGHTNESS OF UNIFORMITY	—	$\theta_x=0^\circ, \theta_y=0^\circ$ IF = 40mA	70	75	—	%		

NOTE (1) : TEST EQUIPMENT SETUP :

AFTER STABILIZING AND LEAVING THE PANEL ALONE AT A GIVEN TEMPERATURE FOR 30 MINUTES. MEASUREMENT SHOULD BE EXECUTED IN A STABLE, WINDLESS, AND DARK ROOM. OPTICAL SPECIFICATIONS ARE MEASURED BY TOPCON BM-7 (FAST) WITH A VIEWING ANGLE OF 1° AT A DISTANCE OF 50cm AND NORMAL DIRECTION.

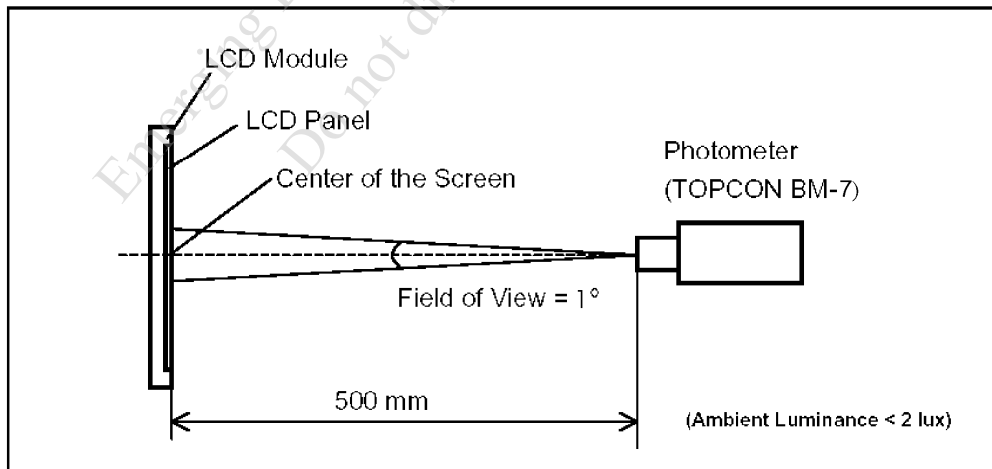

NOTE (2) : DEFINITION OF VIEWING ANGLE :

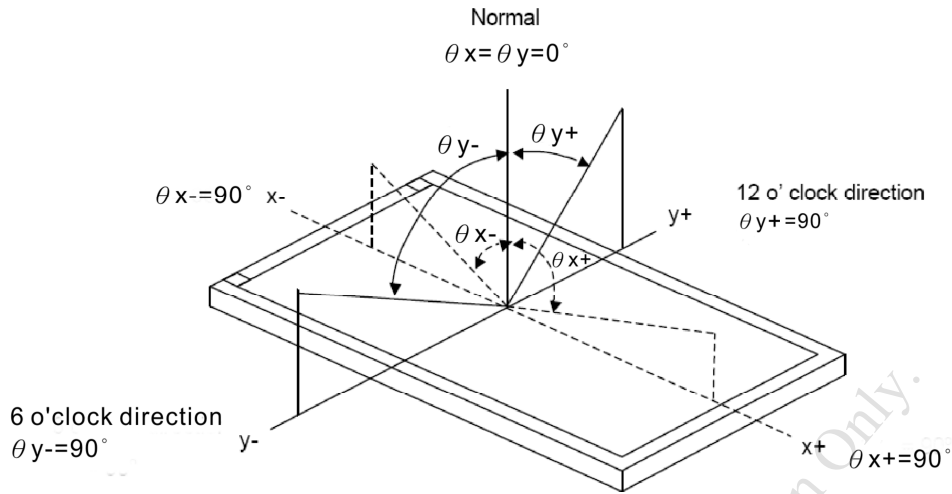

NOTE (3) : DEFINITION OF CONTRAST RATIO :

$$\text{CONTRAST RATIO(CR)} = \frac{\text{BRIGHTNESS MEASURED WHEN LCD IS AT "WHITE STATE"}}{\text{BRIGHTNESS MEASURED WHEN LCD IS AT "BLACK STATE"}}$$

NOTE (4) : DEFINITION OF RESPONSE TIME : T_R AND T_F

THE FIGURE BELOW IS THE OUTPUT SIGNAL OF THE PHOTO DETECTOR.

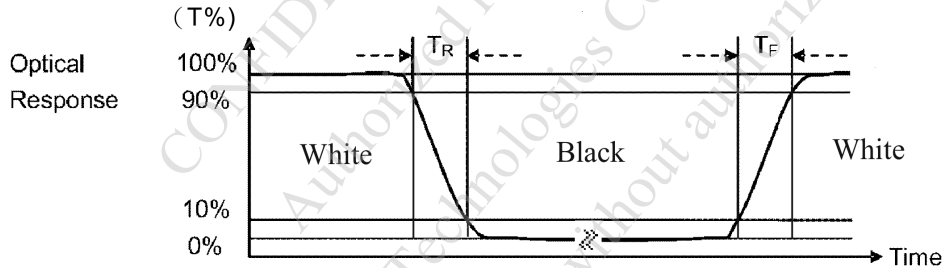

NOTE (5) : BRIGHTNESS MEASURED WHEN LCD IS AT "WHITE STATE".

NOTE (6) : THE 100% TRANSMISSION IS DEFINED AS THE TRANSMISSION OF LCD PANEL WHEN ALL THE INPUT TERMINALS OF MODULE ARE ELECTRICALLY OPENED.

6.2 THE BRIGHTNESS TEST METHOD

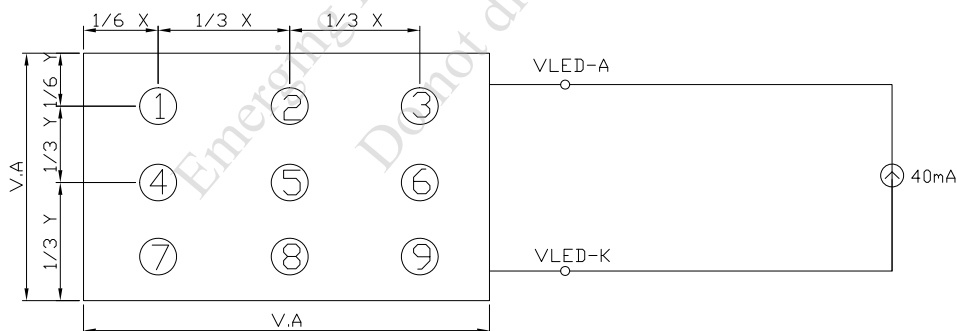

UNIT : mm

6.3 THE BRIGHTNESS UNIFORMITY CALCULATE METHOD

$$\text{UNIFORMITY} = \left[1 - \frac{\text{MAXIMUM BRIGHTNESS} - \text{MINIMUM BRIGHTNESS}}{\text{AVERAGE BRIGHTNESS}} \right] \times 100\%$$

7. OUTLINE DIMENSIONS

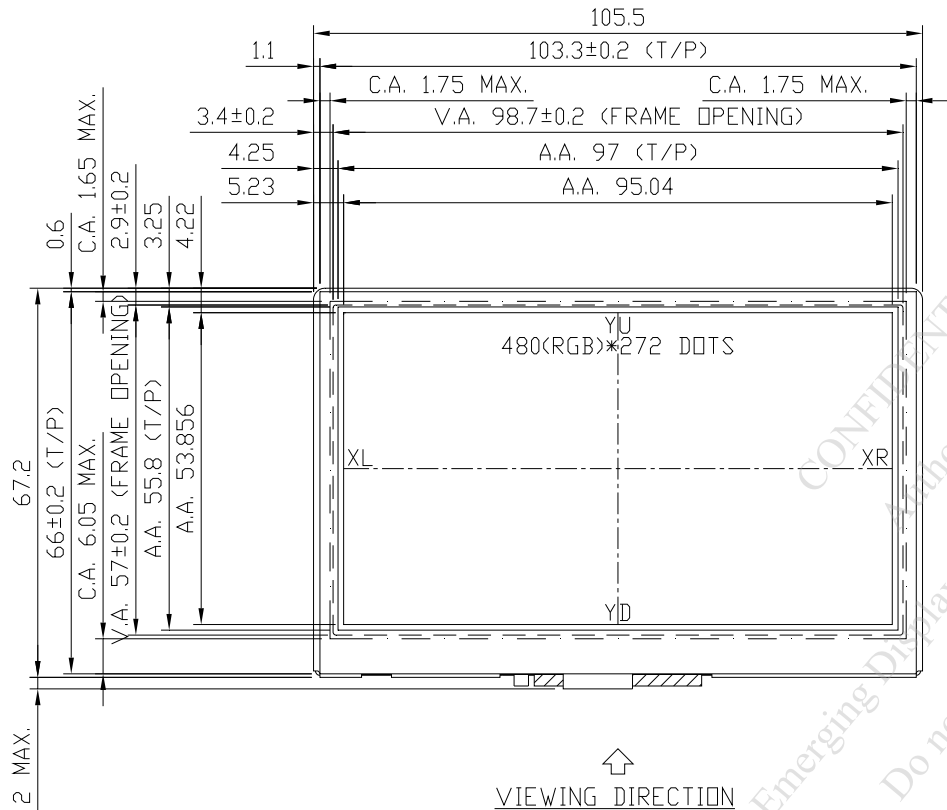

Best Contrast but with Gray Level Inversion

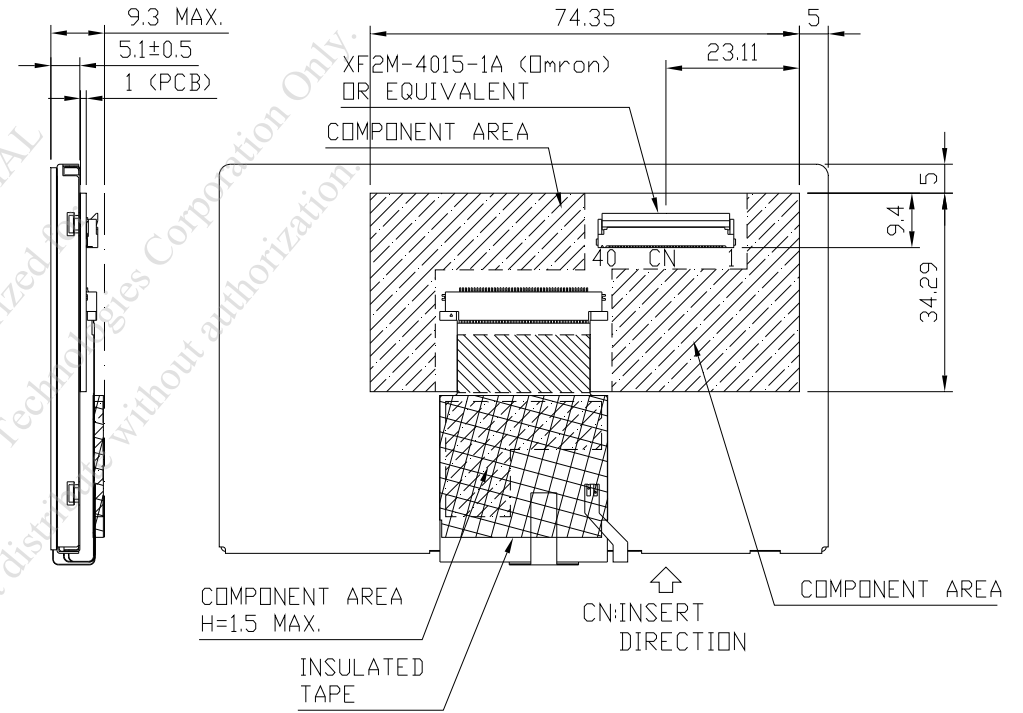

UNIT : mm
SCALE : NTS
NOT SPECIFIED TOLERANCE IS ±0.3mm

9. DETAIL DRAWING OF DOT MATRIX

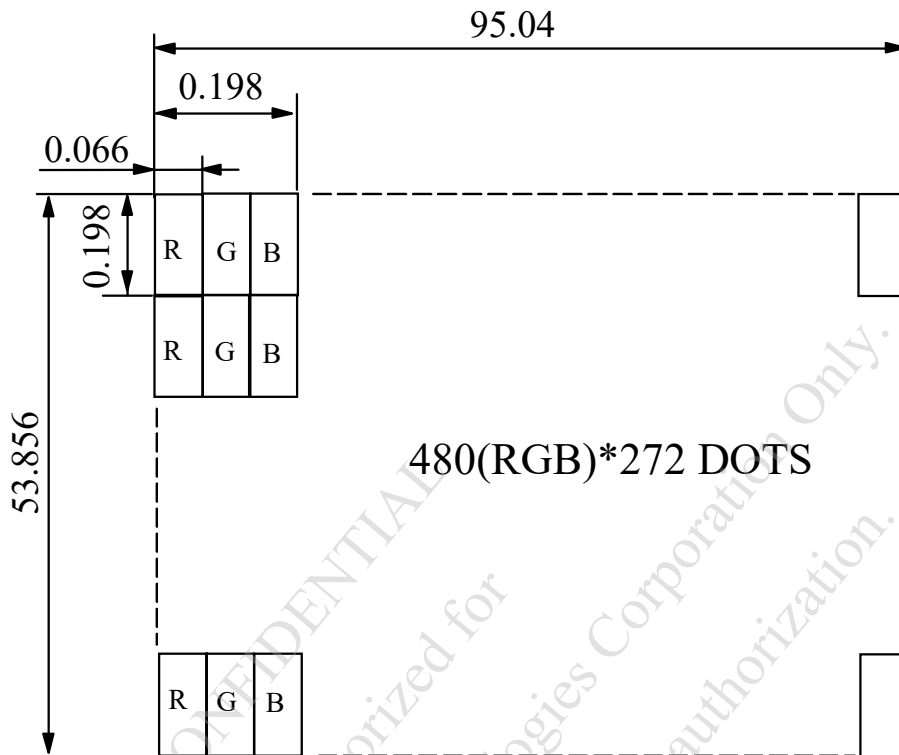

UNIT : mm

SCALE : NTS

NOT SPECIFIED TOLERANCE IS ± 0.1

DOTS MATRIX TOLERANCE IS ± 0.01

CONFIDENTIAL
Authorized for
Emerging Display Technologies Corporation Only.
Do not distribute without authorization.

10. INTERFACE SIGNALS

PIN NO.	SYMBOL	I/O/P	FUNCTION									
1	NC	—	NON CONNECTION									
2	VSS	P	GROUND (VSS IS CONNECTED TO METAL HOUSING WITH CONDUCTIVE TAPE)									
3	B5	I	BLUE DATA BIT 5									
4	B4	I	BLUE DATA BIT 4									
5	B3	I	BLUE DATA BIT 3									
6	B2	I	BLUE DATA BIT 2									
7	B1	I	BLUE DATA BIT 1									
8	B0	I	BLUE DATA BIT 0									
9	VSS	P	GROUND (VSS IS CONNECTED TO METAL HOUSING WITH CONDUCTIVE TAPE)									
10	G5	I	GREEN DATA BIT 5									
11	G4	I	GREEN DATA BIT 4									
12	G3	I	GREEN DATA BIT 3									
13	G2	I	GREEN DATA BIT 2									
14	G1	I	GREEN DATA BIT 1									
15	G0	I	GREEN DATA BIT 0									
16	VSS	P	GROUND (VSS IS CONNECTED TO METAL HOUSING WITH CONDUCTIVE TAPE)									
17	R5	I	RED DATA BIT 5									
18	R4	I	RED DATA BIT 4									
19	R3	I	RED DATA BIT 3									
20	R2	I	RED DATA BIT 2									
21	R1	I	RED DATA BIT 1									
22	R0	I	RED DATA BIT 0									
23	VSS	P	GROUND (VSS IS CONNECTED TO METAL HOUSING WITH CONDUCTIVE TAPE)									
24	DCLK	I	DOT DATA CLOCK									
25	VSS	P	GROUND (VSS IS CONNECTED TO METAL HOUSING WITH CONDUCTIVE TAPE)									
26	HSYNC	I	HORIZONTAL SYNC INPUT WITH NEGATIVE POLARITY. INTERNALLY PULL HIGH.									
27	VSYNC	I	VERTICAL SYNC INPUT WITH NEGATIVE POLARITY. INTERNALLY PULL HIGH.									
28	ENB	I	INPUT DATA ENABLE CONTROL. INTERNALLY PULLED LOW.									
29	PWCTRL	I	<table border="1"> <thead> <tr> <th>LOGIC LEVEL</th> <th>PWCTRL</th> <th>REMARK</th> </tr> </thead> <tbody> <tr> <td>H=3.3V</td> <td>H</td> <td>POWER ON</td> </tr> <tr> <td>L=0V</td> <td>L</td> <td>SHUTDOWN</td> </tr> </tbody> </table>	LOGIC LEVEL	PWCTRL	REMARK	H=3.3V	H	POWER ON	L=0V	L	SHUTDOWN
			LOGIC LEVEL	PWCTRL	REMARK							
H=3.3V	H	POWER ON										
L=0V	L	SHUTDOWN										
<p>WHEN INTERNAL LED DRIVER : JP4 1-2(DEFAULT) WHEN EXTERNAL LED DRIVER : JP4 2-3</p>												

PIN NO.	SYMBOL	I/O/P	FUNCTION
30	VDD	P	POWER SUPPLY VOLTAGE
31	VSS	P	GROUND (VSS IS CONNECTED TO METAL HOUSING WITH CONDUCTIVE TAPE)
32	VSS	P	GROUND (VSS IS CONNECTED TO METAL HOUSING WITH CONDUCTIVE TAPE)
33	VCC	P	POWER SUPPLY FOR LED DRIVER CIRCUIT
34	VCC	P	POWER SUPPLY FOR LED DRIVER CIRCUIT
35	NC	—	NON CONNECTION (USING INTERNAL LED DRIVER) OR ANODE (USING EXTERNAL LED DRIVER) WHEN INTERNAL LED DRIVER : JP1 1-2 (DEFAULT) WHEN EXTERNAL LED DRIVER : JP1 2-3
36	LEDCTRL	I	BRIGHTNESS CONTROL FOR LED BACKLIGHT ; LEDCTRL (USING INTERNAL LED DRIVER) OR CATHODE (USING EXTERNAL LED DRIVER) WHEN INTERNAL LED DRIVER : JP2 1-2 (DEFAULT) JP3 1-2 CONNECT(DEFAULT) WHEN EXTERNAL LED DRIVER : JP2 2-3 JP3 NON CONNECTION
37	YU	—	TOP PANEL
38	XL	—	LEFT PANEL
39	YD	—	BOTTOM PANEL
40	XR	—	RIGHT PANEL
			TOUCH PANEL

11. POWER SUPPLY

11.1 POWER SUPPLY FOR LCM

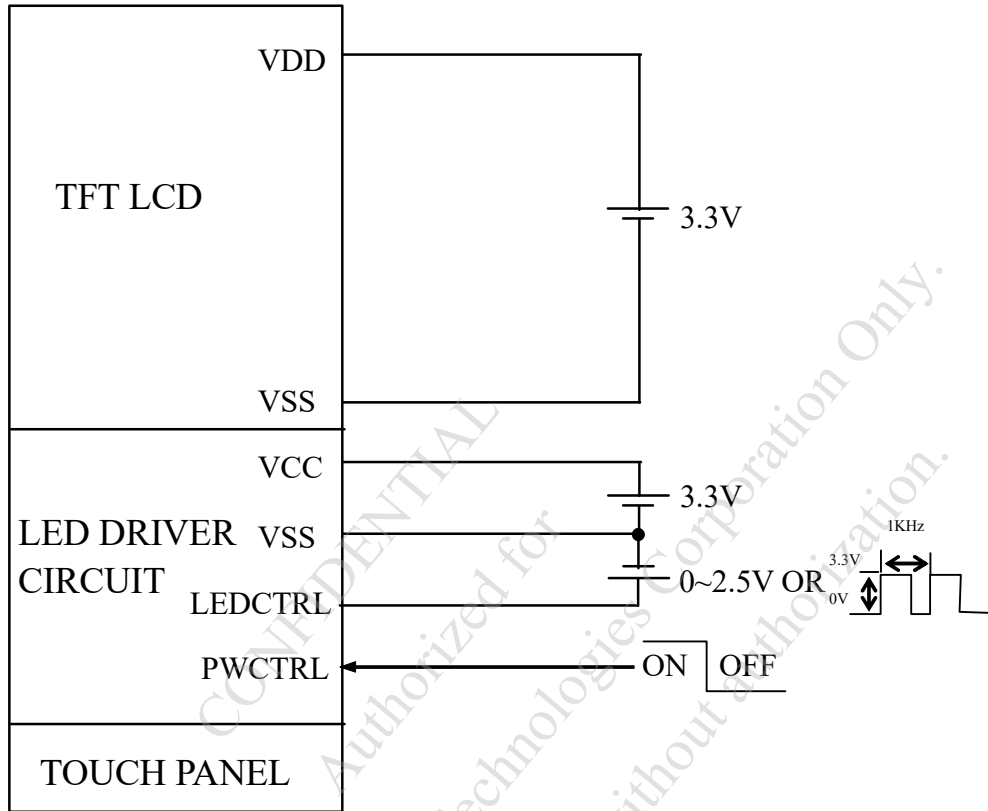

11.2 THE BRIGHTNESS CONTROLLED BY BACKLIGHT CURRENT OF LEDCTRL

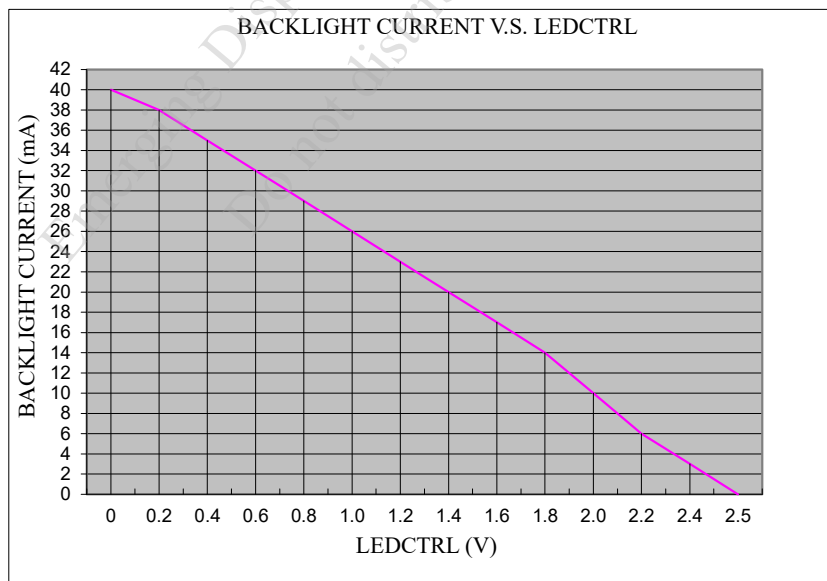

NOTE : LEDCTRL 0~2.5±0.15V

12. TOUCH PANEL SPECIFICATION

12.1 ELECTRICAL CHARACTERISTICS

Ta = 25°C

ITEM	CONDITION	SPEC.	UNIT
LINEARITY	—	≤ 1.5	%
TRANSMISSION	ASTM D1003	Min 80	%
TERMINAL RESISTANCE	X AXIS	440 ~ 1230	Ω
	Y AXIS	700 ~ 250	
INSULATION RESISTANCE	DC25V	≥ 20	MΩ
INPUT VOLTAGE	—	5(TYP)	V

12.2 PRECAUTIONS IN USE OF TOUCH PANEL

12.2.1 PURPOSE :

IN ORDER TO PREVENT ACCIDENTAL USE AND PERFORMANCE DETERIORATION, PLEASE KEEP THE FOLLOWING PRECAUTIONS AND INHIBITED POINTS.

12.2.2 ITEM AND ILLUSTRATION :

(1) STRUCTURE, AREA DEFINITION

THE STRUCTURE AND THE PERFORMANCE GUARANTEED AREA OF THIS TOUCH PANEL ARE DEFINED BELOW :

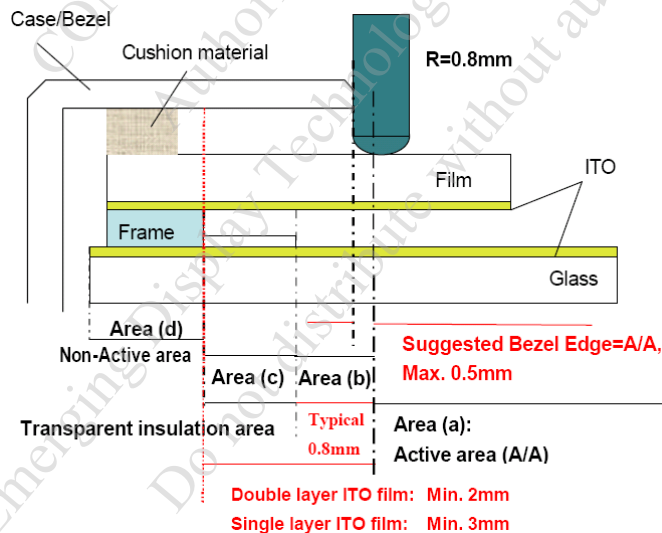

THE ABOVE FIGURE IS OUR DESIGN RULE OF TOUCH PANEL.

IF IT CANNOT MEET YOUR REQUIREMENT, PLEASE CONTACT WITH OUR ENGINEERS FOR FURTHER DISCUSSION.

ABOVE FIGURE ILLUSTRATES THE RECOMMENDED BEZEL AND CUSHION DESIGN. IN ORDER TO PREVENT UNUSUAL PERFORMANCE DEGRADATION AND MALFUNCTION OF A TOUCH PANEL, PLEASE CARRY OUT THE SET CASE DESIGNING AND A TOUCH PANEL ASSEMBLING METHOD AFTER SURELY CONSIDERING THE DEFINITION OF EACH AREA ILLUSTRATED IN ABOVE FIGURE.

AREA(a) : ACTIVE AREA

THE ACTIVE AREA IS GUARANTEED THE POSITION DATA DETECTABLE PRECISION, OPERATION FORCE AND OTHER OPERATIONS. IT IS STRONGLY RECOMMENDED TO PLACE THE OPERATION BUTTON OR MENU KEYS WITHIN THE ACTIVE AREA. DUE TO STRUCTURE, THE ACTIVE AREA IS LESS DURABLE AT THE EDGE OR CLOSE TO THE EDGE.

AREA(b) : OPERATION NON-GUARANTEED AREA

THIS AREA DOES NOT GUARANTEE A TOUCH PANEL OPERATION AND ITS FUNCTION. WHEN THIS AREA IS PRESSED, TOUCH PANEL SHOWS DEGRADATION OF ITS PERFORMANCE AND DURABILITY SUCH AS A PEN SLIDING DURABILITY BECOMES ABOUT ONE-TENTH COMPARED WITH THE ACTIVE AREA (AREA-(A) AS GUARANTEED AREA) AND ITS OPERATION FORCE REQUIRES ABOUT DOUBLE. ABOUT 0.5 MM OUTSIDE FROM A BOUNDARY OF THE ACTIVE AREA CORRESPONDS TO THIS AREA.

AREA(c) : PRESSING PROHIBITION AREA

THE AREA WHICH FORBIDS PRESSING, BECAUSE AN EXCESSIVE LOAD IS APPLIED TO A TRANSPARENT ELECTRODE (ITO) AND A SERIOUS DAMAGE IS GIVEN TO A TOUCH PANEL FUNCTION BY PRESSING.

AREA(d) : NON-ACTIVE AREA

THE AREA DOES NOT ACTIVATE EVEN IF PRESSED.

(2) CAUTIONS FOR INSTALLING AND ASSEMBLING

(i) DO NOT GIVE EXCESSIVE STRAIN TO THE PRODUCT.

(ii) FLEXIBLE PATTERN CABLE IS CONNECTED TO THE BODY BY THERMAL PRESSURE METHOD. SO, DO NOT APPLY EXCESSIVE FORCES TO THE FLEXIBLE PATTERN. DO NOT ADD AN EXCESSIVE FORCE TO A FPC(FLEX TAIL) THAT MAKES PEELING OFF OF THE FPC FROM THE PRODUCT. DO NOT FIX, ADHERE OR MOUNT ANY ADDITIONAL GOODS ON THE FPC SUCH AS ADDITIONAL FILM/PLATE ON THE FPC, BECAUSE SUCH ADDITIONAL GOODS WILL APPLY A STRESS AT THE FPC BONDING AREA. IT MAY AFFECT THE CONDUCTIVITY OF FPC WITH TOUCH PANEL.

(iii) IN ORDER NOT TO APPLY LOAD ON THE DISPLAY, PROVIDE A CLEARANCE OF AT LEAST 0.3MM BETWEEN THE PRODUCT AND DISPLAY.

(iv) WE RECOMMEND THE DESIGN OF A CASE OR BEZEL SHOULD COVERS THE BOUNDARY OF THE ACTIVE AREA INSIDE IN ORDER TO PREVENT AN OPERATION AT OUTSIDE OF THE ACTIVE AREA WHICH CAN NOT GUARANTEE THE FUNCTION OR DURABILITY (REFER TO ITEM 5.1.2. STRUCTURE, AREA DEFINITION).

BEZEL'S EDGE PART MAY GUIDE THE PEN SLIDING ON THE SAME POSITION REPEATEDLY. IF THE BEZEL IS PLACED OUTSIDE OF THE ACTIVE AREA, IT MAY CAUSE THE DAMAGE OF THE ITO FILM.

- (v) PRESSING INSIDE OF BOUNDARY OF THE FRAME(PART (A) AS SHOWN IN BELOW) MAY CAUSES FAULT OPERATION, SO PLEASE DESIGN TO AVOID PRESSING OF TOUCH PANEL AT PART (A) SUCH AS HAVING GASKET/CUSHION AT PART (C). PARTICULARLY THE AREA (B) SHALL BE FREE FROM BURR. THE GASKET/CUSHION MATERIAL AT THE PART (C) SHOULD NOT BE EXCEEDED TO INSIDE OF THE BOUNDARY OF THE FRAME.

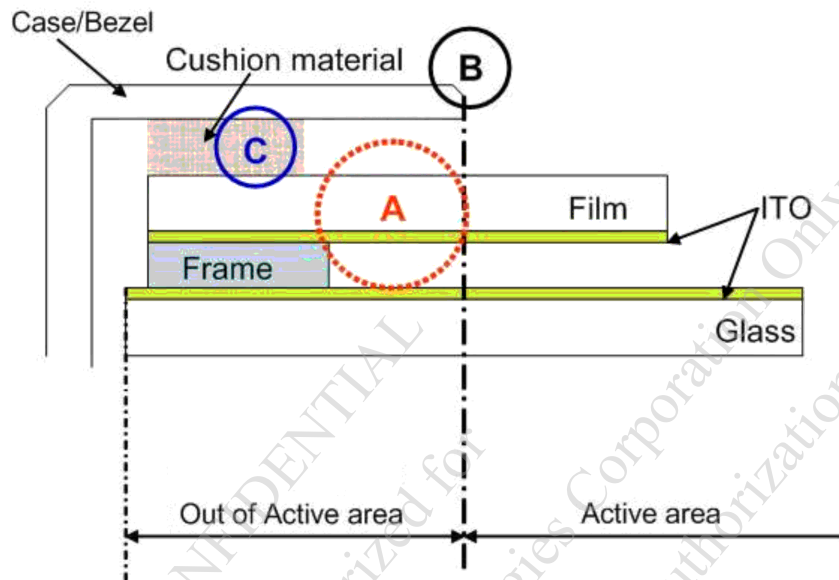

- (vi) TO PREVENT GIVING DISTORTION TO THE FILM OF THE PRODUCT AND PEELING OFF OF THE FILM FROM THE PRODUCT, DO NOT FIX THE FILM AND A SET CASE OR A SHOCK ABSORBING MATERIAL ADHERED TO A SET CASE BY ADHESION.
- (vii) WIPE OFF THE STAIN ON THE PRODUCT BY USING SOFT CLOTH MOISTENED WITH ETHANOL. TAKE CARE NOT TO ALLOW ETHANOL TO SOAK INTO THE JOINT OF UPPER FILM AND BOTTOM GLASS. IT MAY OTHERWISE CAUSE PEELING OR DEFECTIVE OPERATION. DO NOT USE ANY ORGANIC SOLVENT OR DETERGENT OTHER THAN ETHANOL.
- (viii) THE CORNERS OF THE PRODUCT ARE NOT CHAMFERED AND ARE SHARP. WHEN POSITIONING AND FIXING THE PRODUCT ON THE CASE, PROVIDE A ROUND PART ON THE CORNER OF THE CASE SO AS NOT TO APPLY LOAD ON THE CORNER OF THE TRANSPARENT TOUCH PANEL.
- (ix) DO NOT PRESS THE FILM OF THE PRODUCT WHEN THIS PRODUCT IS BUILT INTO A SET.
- (3) CAUTIONS FOR OPERATION
- (i) OPERATE IT WITH A POLYACETAL PEN (TIP R0.8 OR OVER) OR A BELLY OF A FINGER WITHOUT APPLYING EXCESSIVE LOAD. NEVER USE ANY MECHANICAL PENCILS, BALL POINT PENS AND HARD FINGERTIPS WHOSE TIP IS HARD FOR INPUT, OTHERWISE MALFUNCTIONS MAY RESULT.

- (ii) THE INPUT POSITION MAY BE FLUCTUATED A LITTLE THROUGH LONG-TIME USE. IT IS DESIRABLE TO PROVIDE A ZERO-ADJUSTMENT FUNCTION BY USING A CIRCUIT AND SOFTWARE.
- (iii) OPERATION AT THE OUT OF ACTIVE AREA IS OUT OF OUR GUARANTEE. IT CAUSES A SERIOUS DAMAGE OF A TRANSPARENT ELECTRODE. DO NOT OPERATE AT THE OUT OF ACTIVE AREA.
- (iv) IN CASE OF CLEANING THE PART OF THE CASE BOUNDARY OF ACCOMPLISHED SET, USE A SOFT CLOTH WITH A FINGER BERRY OR A COTTON BUD. DO NOT CLEAN WITH A THING OTHER THAN THE FINGER SUCH AS HARD OR SHARP EDGES LIKE A FINGER NAIL ETC. ON THE CLOTH, BECAUSE IT CAUSE TRANSPARENT CONDUCTIVE FILM CRACKS. PLEASE ADVISE THIS PROHIBITION TO YOUR LAST CUSTOMERS.

12.3 DURABILITY

12.3.1 STYLUS HITTING :

ONE MILLION TIMES OR OVER
NO DAMAGE ON FILM SURFACE
PEN : R8 mm SILICON RUBBER
LOAD : 250g
FREQUENCY : 240 times/min
MEASUREMENT POSITION:
1 POINT OF TOUCH PANEL ACTIVE AREA
REPEATED : OVER 1,000,000 TIMES

12.3.2 PEN TOUCH SLIDING DURABILITY :

100,000 TIMES OR OVER
WRITING WITH R0.8mm PLASTIC STYLUS PEN; WRITING FORCE 150g
IN ACTIVE AREA.
SPEED IS 60mm/sec.

12.4 STEEL BALL DROP TEST

BY USING F9mm STEEL BALL FROM THE HEIGHT OF 30cm AND FALLING ON TOUCH PANEL SURFACE, MUST PASS BELOW CONDITIONS :

APPEARANCE : THE APPEARANCE WITHOUT ANY CHANGE, INCLUDING THE PANEL BROKEN.

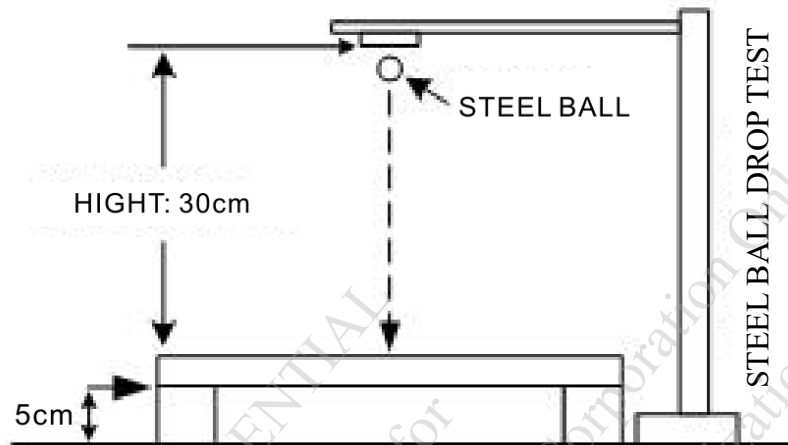

12.5 APPEARANCE INSPECTION

PURPOSE :

TO ESTABLISH APPEARANCE STANDARD AND MAINTAIN PRODUCT QUALITY.

SCOPE :

TOUCH PANEL VIEW AREA WITHIN TOUCH PANEL.

12.5.1 RULE :

INSPECTION CONDITION

(A) ENVIRONMENTAL LUMINANCE : 500 LUX.

(B) DISTANCE BETWEEN HUMAN EYES AND PANEL : 30 cm

(PANEL MUST BE TESTED UNDER LIGHT TRANSPARENT).

(C) VISUAL ANGLE : $> 60^\circ$.

(D) LIGHT SOURCE : FLUORESCENT LIGHT SOURCE.

12.5.2 JUDGE CRITERION :

JUDGEMENT UNDER ABOVE MENTIONED CRITERION (PANEL MUST BE TESTED UNDER LIGHT TRANSPARENT), TESTING GOODS DEFECT CAN BE VISIBLE WITHIN 10 SECONDS, WHICH WILL BE JUDGED AS MAJOR DEFECTS.

SAMPLING STANDARD :

THE SAMPLING STANDARD WILL BE CONFIRMED BY BOTH OF EDT AND CUSTOMER.

INSPECTION ITEMS	SPEC.	JUDGE CRITERION	OPERATION GUIDELINE
SCRATCH	$W \geq 0.10\text{mm}$ or $L \geq 10\text{mm}$	NOT ACCEPTABLE	
	$0.10\text{mm} > W > 0.05\text{mm}$ and $L < 10\text{mm}$	MAX. 4EA EA	
	$W < 0.05\text{mm}$ and $L < 10\text{mm}$	ACCEPTABLE	
LINEAR FOREIGN OBJECT	$W \leq 0.05\text{mm}$ & $L \leq 3\text{mm}$	ACCEPTABLE	
	$W > 0.05\text{mm}$ or $L > 3\text{mm}$	NOT ACCEPTABLE	
GRANULAR FOREIGN OBJECT	$D \leq 0.1\text{mm}$	ACCEPTABLE	
	$0.1\text{mm} < D \leq 0.2\text{mm}$	MAX. 5 EA	
	$0.2\text{mm} < D \leq 0.3\text{mm}$	MAX. 3 EA	
	$D > 0.30\text{mm}$	NOT ACCEPTABLE	
PET BUBBLES	$D \leq 0.5\text{mm}$	ACCEPTABLE	
	$D > 0.5\text{mm}$	NOT ACCEPTABLE	
CHIP ON GLASS	CORNER $X \leq 1.5\text{mm}$ · $Y \leq 1.5\text{mm}$ · $Z \leq t$ (t = /thickness)	ACCEPTABLE	
	EDGE $X \leq 3\text{mm}$ · $Y \leq 1.5\text{mm}$ · $Z \leq t$		

CONFIDENTIAL
 Emerging Display Technologies Corporation
 Do not distribute without authorization.

13. INSPECTION CRITERION

13.1 APPLICATION

THIS INSPECTION STANDARD IS TO BE APPLIED TO THE LCD MODULE DELIVERED FROM EMERGING DISPLAY TECHNOLOGIES CORP.(E.D.T) TO CUSTOMERS

13.2 INSPECTION CONDITIONS

13.2.1 (1)OBSERVATION DISTANCE : 45 ± 5 cm

(2)VIEWING ANGLE : $\pm 45^\circ$

$\pm 45^\circ$ (FOR SECTION WITHIN VIEWING AREA), REFER TO FIG.A
 90° (FOR SECTION OUTSIDE OF VIEWING AREA), REF TO FIG.B
 PERPENDICULAR TO MODULE SURFACE

VIEWING ANGLE SHOULD BE SMALLER THAN 45°

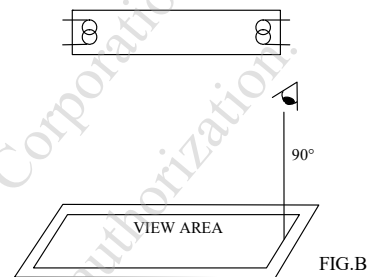
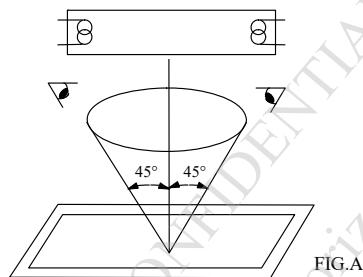

THE INSPECTION CRITERIA IS ACCORDING TO LINE OF SIGHT. INSPECTION SHALL BE MADE WITHIN THE HALF SECTION OF THE VIEWING CONE GENERATED BY LINE SEGMENT OF 45° WITH RESPECTS TO THE VERTICAL AXIS FROM CENTER VERTEX OF LCD, THE FLUORESCENT LAMP AND THE CONE AXIS MUST BE PERPENDICULAR TO THE LCD SURFACE.

IF THE DEFECTS ARE OUTSIDE OF VIEWING AREA, IT SHALL BE INSPECTED BY 90° WITH RESPECTS TO THE VERTICAL AXIS FROM EDGE OF VIEWING AREA.

13.2.2 ENVIRONMENT CONDITIONS :

AMBIENT TEMPERATURE		$25 \pm 5^\circ\text{C}$
AMBIENT HUMIDITY		$65 \pm 20\% \text{RH}$
AMBIENT ILLUMINATION	COSMETIC INSPECTION	600~800 lux
	FUNCTIONAL INSPECTION	300~500 lux
INSPECTION TIME		10 secs

13.2.3 INSPECTION LOT

QUANTITY PER DELIVERY LOT FOR EACH MODEL

13.2.4 A SAMPLING INSPECTION SHALL BE MADE ACCORDING TO THE FOLLOWING PROVISIONS TO JUDGE THE ACCEPTABILITY

(a)APPLICABLE STANDARD :

ANSI/ ASQ Z1.4 NORMAL INSPECTION LEVEL II

(b)AQL : MAJOR DEFECT : AQL 0.65

MINOR DEFECT : AQL 1.0

13.3 INSPECTION STANDARDS

13.3.1 VISUAL DEFECTS CLASSIFICATION

TYPE OF DEFECT	INSPECTION ITEM	DEFECT FEATURE	AQL
MAJOR DEFECT	1.DISPLAY ON	<ul style="list-style-type: none"> • DEFECT TO MISS SPECIFIED DISPLAY FUNCTION, FOR ALL AND SPECIFIED DOTS EX: DISCONNECTION, SHORT CIRCUIT ETC 	0.65
	2.BACKLIGHT	<ul style="list-style-type: none"> • NO LIGHT • FLICKERING AND OTHER ABNORMAL ILLUMINATION 	
	3.DIMENSIONS	<ul style="list-style-type: none"> • SUBJECT TO INDIVIDUAL ACCEPTANCE SPECIFICATIONS 	
MINOR DEFECT	1.DISPLAY ZONE	<ul style="list-style-type: none"> • BLACK/WHITE SPOT • BUBBLES ON POLARIZER • NEWTON RING • BLACK/WHITE LINE • SCRATCH • CONTAMINATION • LEVER COLOR SPREAD 	1.0
	2.BEZEL ZONE	<ul style="list-style-type: none"> • STAINS • SCRATCHES • FOREIGN MATTER 	
	3.SOLDERING	<ul style="list-style-type: none"> • INSUFFICIENT SOLDER • SOLDERED IN INCORRECT POSITION • CONVEX SOLDERING SPOT • SOLDER BALLS • SOLDER SCRAPS 	
	4.DISPLAY ON (ALL ON)	<ul style="list-style-type: none"> • LIGHT LINE 	

13.3.2 MODULE DEFECTS CLASSIFICATION

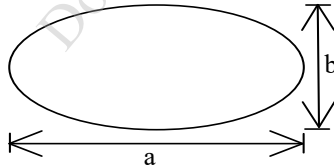
NO.	ITEM	CRITERIA												
1	DISPLAY ON INSPECTION	1. INCORRECT PATTERN 2. MISSING SEGMENT 3. DIM SEGMENT 4. OPERATING VOLTAGE BEYOND SPEC												
2	OVERALL DIMENSIONS	1. OVERALL DIMENSION BEYOND SPEC												
3	DOT DEFECT	<p>1. INSPECTION PATTERN: FULL WHITE, FULL BLACK, RED, GREEN AND BLUE SCREENS.</p> <p>2.</p> <table border="1"> <thead> <tr> <th>ITEMS</th> <th>ACCEPTABLE COUNT</th> </tr> </thead> <tbody> <tr> <td>BRIGHT DOT</td> <td>$N \leq 2$</td> </tr> <tr> <td>DARK DOT</td> <td>$N \leq 3$</td> </tr> <tr> <td>TOTAL BRIGHT AND DARK DOTS</td> <td>$N \leq 4$</td> </tr> </tbody> </table> <p>NOTE :</p> <p>1. THE DEFINITION OF DOT : THE SIZE OF A DEFECTIVE DOT OVER 1/2 OF WHOLE DOT IS REGARDED AS ONE DEFECTIVE DOT.</p> <p>2. BRIGHT DOT : DOTS APPEAR BRIGHT AND UNCHANGED IN SIZE IN WHICH LCD PANEL IS DISPLAYING UNDER BLACK PATTERN.</p> <p>3. DARK DOT : DOTS APPEAR DARK AND UNCHANGED IN SIZE IN WHICH LCD PANEL IS DISPLAYING UNDER PURE RED, GREEN, BLUE PICTURE.</p>	ITEMS	ACCEPTABLE COUNT	BRIGHT DOT	$N \leq 2$	DARK DOT	$N \leq 3$	TOTAL BRIGHT AND DARK DOTS	$N \leq 4$				
ITEMS	ACCEPTABLE COUNT													
BRIGHT DOT	$N \leq 2$													
DARK DOT	$N \leq 3$													
TOTAL BRIGHT AND DARK DOTS	$N \leq 4$													
4	FOREIGN BLACK/WHITE/ BRIGHT LINE/ SCRATCH OF VIEWING AREA	<table border="1"> <thead> <tr> <th>LENGTH : L</th> <th>WIDTH : W</th> <th>PERMISSIBLE NO.</th> </tr> </thead> <tbody> <tr> <td>$L \leq 0.3$</td> <td>$W \leq 0.05$</td> <td>IGNORE</td> </tr> <tr> <td>$0.3 < L \leq 2.5$</td> <td>$0.05 < W \leq 0.1$</td> <td>4</td> </tr> <tr> <td>$2.5 < L$</td> <td>$0.1 < W$</td> <td>NONE</td> </tr> </tbody> </table> <p>WIDTH : W mm, LENGTH : L mm</p>	LENGTH : L	WIDTH : W	PERMISSIBLE NO.	$L \leq 0.3$	$W \leq 0.05$	IGNORE	$0.3 < L \leq 2.5$	$0.05 < W \leq 0.1$	4	$2.5 < L$	$0.1 < W$	NONE
LENGTH : L	WIDTH : W	PERMISSIBLE NO.												
$L \leq 0.3$	$W \leq 0.05$	IGNORE												
$0.3 < L \leq 2.5$	$0.05 < W \leq 0.1$	4												
$2.5 < L$	$0.1 < W$	NONE												
5	FOREIGN MATTER \ BLACK SPOTS \ WHITE SPOTS \ DENT (INCLUDING LIGHT LEAKAGE DUE TO POLARIZING PLATES PINHOLES, ETC.)	<table border="1"> <thead> <tr> <th>AVERAGE DIAMETER (mm): D</th> <th>NUMBER OF PIECES PERMITTED</th> </tr> </thead> <tbody> <tr> <td>$D \leq 0.15$</td> <td>IGNORE</td> </tr> <tr> <td>$0.15 < D \leq 0.5$</td> <td>4</td> </tr> <tr> <td>$0.5 < D$</td> <td>NONE</td> </tr> </tbody> </table> <p>NOTE : DIAMETER $D=(a+b)/2$</p> 	AVERAGE DIAMETER (mm): D	NUMBER OF PIECES PERMITTED	$D \leq 0.15$	IGNORE	$0.15 < D \leq 0.5$	4	$0.5 < D$	NONE				
AVERAGE DIAMETER (mm): D	NUMBER OF PIECES PERMITTED													
$D \leq 0.15$	IGNORE													
$0.15 < D \leq 0.5$	4													
$0.5 < D$	NONE													

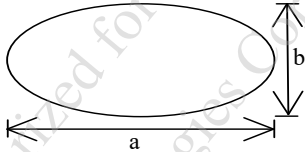
NO.	ITEM	CRITERIA		
			AVERAGE DIAMETER (mm) : D	NUMBER OF PIECES PERMITTED
6	BUBBLES OF POLARIZER /DIRT/CF FAIL /SURFACE STAINS	BUBBLE ON THE POLARIZER	$D \leq 0.25$	IGNORE
			$0.25 < D \leq 0.5$	$N \leq 5$
			$0.5 < D$	NONE
		SURFACE STAINS	$D < 0.1$	IGNORE
			$0.1 < D \leq 0.3$	$N \leq 3$
		CF FAIL / SPOT	$D < 0.1$	IGNORE
		$0.1 < D \leq 0.3$	$N \leq 3$	
		<p>NOTE : (1)POLARIZER BUBBLE IS DEFINED AS THE BUBBLE APPEARS ON ACTIVE DISPLAY AREA. THE DEFECT OF POLARIZER BUBBLE SHALL BE IGNORED IF THE POLARIZER BUBBLE APPEARS ON THE OUTSIDE OF ACTIVE DISPLAY AREA.</p> <p>(2)THE EXTRANEIOUS SUBSTANCE IS DEFINED AS IT CAN BE OBSERVED WHEN THE MODULE IS POWER ON.</p> <p>(3)THE DEFINITION OF AVERAGE DIAMETER, D IS DEFINED AS FOLLOWING.</p> <p>AVERAGE DIAMETER (D)=(a+b)/2</p> 		
7	LINE DEFECT ON DISPLAY	OBVIOUS VERTICAL OR HORIZONTAL LINE DEFECT IS NOT ALLOWED		
8	MURA ON DISPLAY	IT'S OK IF MURA IS SLIGHT VISIBLE THROUGH 6% ND FILTER		
9	UNEVEN COLOR SPREAD, COLORATION	1. TO BE DETERMINED BASED UPON THE STANDARD SAMPLE.		
10	BEZEL APPEARANCE	<p>1. BEZEL MAY NOT HAVE RUST, BE DEFORMED OR HAVE FINGER PRINTS STAINS OF OTHER CONTAMINATION.</p> <p>2. BEZEL MUST COMPLY WITH JOB SPECIFICATIONS.</p>		
11	PCB/FPC	<p>1. THERE MAY NOT BE MORE THAN 2mm OF SEALANT OUTSIDE THE SEAL AREA ON THE PCB, AND THERE SHOULD BE NO MORE THAN THREE PLACES.</p> <p>2. NO OXIDATION OR CONTAMINATION PCB TERMINALS.</p> <p>3. PARTS ON PCB MUST BE THE SAME AS ON THE PRODUCTION CHARACTERISTIC CHART. THERE SHOULD BE NO WRONG PARTS, MISSING PARTS OR EXCESS PARTS.</p> <p>4. THE JUMPER ON THE PCB SHOULD CONFORM TO THE PRODUCT CHARACTERISTIC CHART.</p> <p>5. IF SOLDER GETS ON BEZEL TAB PADS, LED PAD, ZEBRA PAD OR SCREW HOLD PAD; MAKE SURE IT IS SMOOTHED DOWN.</p>		

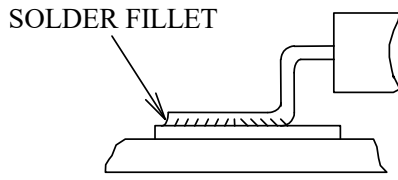
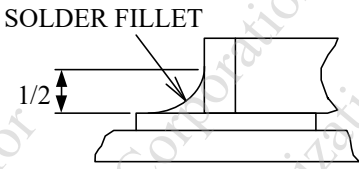
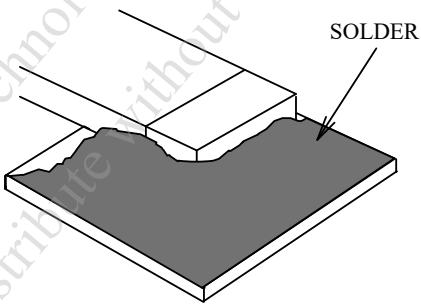
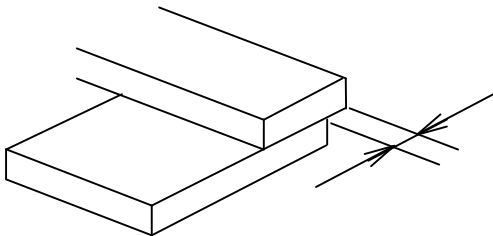
NO.	ITEM	CRITERIA
12	SOLDERING	<p>1. NO SOLDERING FOUND ON THE SPECIFIED PLACE</p> <p>2. INSUFFICIENT SOLDER</p> <p>(a) LSI, IC A POOR WETTING OF SOLDER IS BETWEEN LOWER BEND OR "HEEL" OF LEAD AND PAD</p>  <p>(b) CHIP COMPONENT · SOLDER IS LESS THAN 50% OF SIDES AND FRONT FACE WETTING</p>  <p>· SOLDER WETS 3 SIDES OF TERMINAL, BUT LESS THAN 25% OF SIDES AND FRONT SURFACE AREA ARE COVERED</p>  <p>3. PARTS ALIGNMENT</p> <p>(a) LSI, IC LEAD WIDTH IS MORE THAN 50% BEYOND PAD OUTLINE</p> 

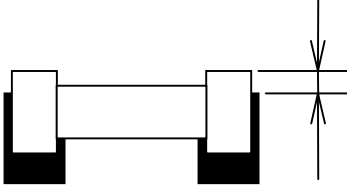
NO.	ITEM	CRITERIA
12	SOLDERING	<p>(b)CHIP COMPONENT COMPONENT IS OFF CENTER, AND MORE THAN 50% OF THE LEADS IS OFF THE PAD OUTLINE</p>  <p>4. NO UNMELTED SOLDER PASTE MAY BE PRESENT ON THE PCB. 5. NO COLD SOLDER JOINTS, MISSING SOLDER CONNECTIONS, OXIDATION OR ICICLE. 6. NO RESIDUE OR SOLDER BALLS ON PCB. 7. NO SHORT CIRCUITS IN COMPONENTS ON PCB.</p>
13	BACKLIGHT	<p>1. NO LIGHT 2. FLICKERING AND OTHER ABNORMAL ILLUMINATION 3. SPOTS OR SCRATCHES THAT APPEAR WHEN LIT MUST BE JUDGED USING LCD SPOT, LINES AND CONTAMINATION STANDARDS. 4. BACKLIGHT DOESN'T LIGHT OR COLOR IS WRONG.</p>
14	GENERAL APPEARANCE	<p>1. NO OXIDATION, CONTAMINATION, CURVES OR, BENDS ON INTERFACE PIN (OLB) OF TCP. 2. NO CRACKS ON INTERFACE PIN (OLB) OF TCP. 3. NO CONTAMINATION, SOLDER RESIDUE OR SOLDER BALLS ON PRODUCT. 4. THE IC ON THE TCP MAY NOT BE DAMAGED, CIRCUITS. 5. THE UPPERMOST EDGE OF THE PROTECTIVE STRIP ON THE INTERFACE PIN MUST BE PRESENT OR LOOK AS IF IT CAUSE THE INTERFACE PIN TO SEVER. 6. THE RESIDUAL ROSIN OR TIN OIL OF SOLDERING (COMPONENT OR CHIP COMPONENT) IS NOT BURNED INTO BROWN OR BLACK COLOR. 7. SEALANT ON TOP OF THE ITO CIRCUIT HAS NOT HARDENED. 8. PIN TYPE MUST MATCH TYPE IN SPECIFICATION SHEET. 9. LCD PIN LOOSE OR MISSING PINS. 10. PRODUCT PACKAGING MUST THE SAME AS SPECIFIED ON PACKAGING SPECIFICATION SHEET. 11. PRODUCT DIMENSION AND STRUCTURE MUST CONFORM TO PRODUCT SPECIFICATION SHEET. 12. THE APPEARANCE OF HEAT SEAL SHOULD NOT ADMIT ANY DIRT AND BREAK.</p>

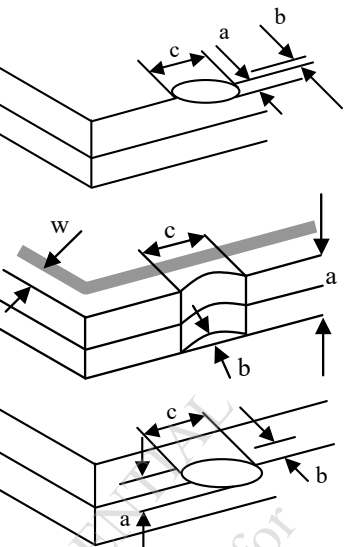
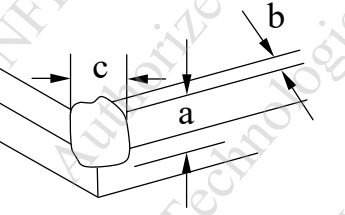
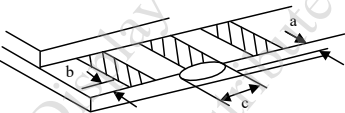
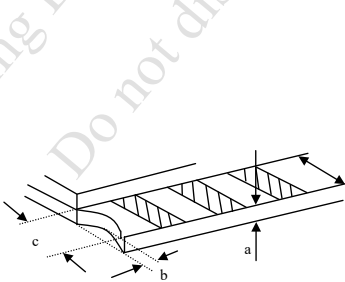
NO.	ITEM	CRITERIA										
15	CRACKED GLASS	<p>THE LCD WITH EXTENSIVE CRACK IS NOT ACCEPTABLE</p>										
		<p>GENERAL GLASS CHIP :</p> 	<table border="1" data-bbox="935 416 1458 495"> <thead> <tr> <th>a</th> <th>b</th> <th>c</th> </tr> </thead> <tbody> <tr> <td>$\leq t/2$</td> <td>< VIEWING AREA</td> <td>$\leq 1/8X$</td> </tr> <tr> <td>$t/2 >, \leq 2t$</td> <td>$\leq W/2$</td> <td>$\leq 1/8X$</td> </tr> </tbody> </table> <p>*W=DISTANCE BETWEEN SEALANT AREA AND LCD PANEL EDGE X = LCD SIDE LENGTH t = GLASS THICKNESS</p>	a	b	c	$\leq t/2$	< VIEWING AREA	$\leq 1/8X$	$t/2 >, \leq 2t$	$\leq W/2$	$\leq 1/8X$
		a	b	c								
		$\leq t/2$	< VIEWING AREA	$\leq 1/8X$								
		$t/2 >, \leq 2t$	$\leq W/2$	$\leq 1/8X$								
<p>CORNER PART :</p> 	<table border="1" data-bbox="935 1001 1458 1079"> <thead> <tr> <th>a</th> <th>b</th> <th>c</th> </tr> </thead> <tbody> <tr> <td>$\leq t/2$</td> <td>< VIEWING AREA</td> <td>$\leq 1/8X$</td> </tr> <tr> <td>$> t/2, \leq 2t$</td> <td>$\leq W/2$</td> <td>$\leq 1/8X$</td> </tr> </tbody> </table> <p>*W=DISTANCE BETWEEN SEALANT AREA AND LCD PANEL EDGE X = LCD SIDE LENGTH t = GLASS THICKNESS</p>	a	b	c	$\leq t/2$	< VIEWING AREA	$\leq 1/8X$	$> t/2, \leq 2t$	$\leq W/2$	$\leq 1/8X$		
a	b	c										
$\leq t/2$	< VIEWING AREA	$\leq 1/8X$										
$> t/2, \leq 2t$	$\leq W/2$	$\leq 1/8X$										
<p>CHIP ON ELECTRODE PAD</p> 	<table border="1" data-bbox="935 1274 1458 1330"> <thead> <tr> <th>a</th> <th>b</th> <th>c</th> </tr> </thead> <tbody> <tr> <td>$\leq t$</td> <td>$\leq 0.5\text{mm}$</td> <td>$\leq 1/8X$</td> </tr> </tbody> </table> <p>* X=LCD SIDE WIDTH t=GLASS THICKNESS</p>	a	b	c	$\leq t$	$\leq 0.5\text{mm}$	$\leq 1/8X$					
a	b	c										
$\leq t$	$\leq 0.5\text{mm}$	$\leq 1/8X$										
	<table border="1" data-bbox="935 1426 1458 1482"> <thead> <tr> <th>a</th> <th>b</th> <th>c</th> </tr> </thead> <tbody> <tr> <td>$\leq t$</td> <td>$\leq 1/8X$</td> <td>$\leq L$</td> </tr> </tbody> </table> <p>*X=LCD SIDE WIDTH t = GLASS THICKNESS L=ELECTRODE PAD LENGTH ①IF GLASS CHIPPING THE ITO TERMINAL, OVER 2/3 OF THE ITO MUST REMAIN AND BE, INSPECTED ACCORDING TO ELECTRODE TERMINAL SPECIFICATIONS ②IF THE PRODUCT WILL BE HEAT SEALED BY THE CUSTOMER, THE ALIGNMENT MARK MUST NOT BE DAMAGED</p>	a	b	c	$\leq t$	$\leq 1/8X$	$\leq L$					
a	b	c										
$\leq t$	$\leq 1/8X$	$\leq L$										

13.4 RELIABILITY TEST

13.4.1 STANDARD SPECIFICATIONS FOR RELIABILITY OF LCD MODULE

NO.	ITEM	DESCRIPTION
1	HIGH TEMPERATURE OPERATION	THE SAMPLE SHOULD BE ALLOWED TO STAND AT +70°C FOR 240 HRS
2	LOW TEMPERATURE OPERATION	THE SAMPLE SHOULD BE ALLOWED TO STAND AT -20°C FOR 240 HRS
3	HIGH TEMPERATURE STORAGE	THE SAMPLE SHOULD BE ALLOWED TO STAND AT +80°C FOR 240 HRS
4	LOW TEMPERATURE STORAGE	THE SAMPLE SHOULD BE ALLOWED TO STAND AT -30°C FOR 240 HRS
5	HIGH TEMPERATURE /HUMIDITY TEST STORAGE	THE SAMPLE SHOULD BE ALLOWED TO STAND AT 60°C , 90% RH 240 HRS
6	THERMAL SHOCK (NOT OPERATED)	<p>THE SAMPLE SHOULD BE ALLOWED TO STAND THE FOLLOWING 10 CYCLES OF OPERATION:</p>
7	ESD (ELECTROSTATIC DISCHARGE) (NOT OPERATED)	AIR DISCHARGE ± 12KV CONTACT DISCHARGE ± 8KV (ACCORDING TO IEC-61000-4-2)

NOTE (1) : THE TEST SAMPLES HAVE RECOVERY TIME FOR 2 HOURS AT ROOM TEMPERATURE BEFORE THE FUNCTION CHECK. IN THE STANDARD CONDITIONS, THERE IS NO DISPLAY FUNCTION NG ISSUE OCCURRED.

13.5 TESTING CONDITIONS AND INSPECTION CRITERIA

FOR THE FINAL TEST THE TESTING SAMPLE MUST BE STORED AT ROOM TEMPERATURE FOR 24 HOURS, AFTER THE TESTS LISTED IN TABLE 13.4, STANDARD SPECIFICATIONS FOR RELIABILITY HAVE BEEN EXECUTED IN ORDER TO ENSURE STABILITY.

NO.	ITEM	TEST MODEL	INSPECTION CRITERIA
1	CURRENT CONSUMPTION	REFER TO SPECIFICATION	THE CURRENT CONSUMPTION SHOULD CONFORM TO THE PRODUCT SPECIFICATION.
2	CONTRAST	REFER TO SPECIFICATION	AFTER THE TESTS HAVE BEEN EXECUTED, THE CONTRAST MUST BE LARGER THAN HALF OF ITS INITIAL VALUE PRIOR TO THE TESTS.
3	APPEARANCE	VISUAL INSPECTION	DEFECT FREE

13.6 OPERATION

- 13.6.1 DO NOT CONNECT OR DISCONNECT MODULES TO OR FROM THE MAIN SYSTEM WHILE POWER IS BEING SUPPLIED.
- 13.6.2 USE THE MODULE WITHIN SPECIFIED TEMPERATURE ; LOWER TEMPERATURE CAUSES THE RETARDATION OF BLINKING SPEED OF THE DISPLAY ; HIGHER TEMPERATURE MAKES OVERALL DISPLAY DISCOLOR . WHEN THE TEMPERATURE RETURNS TO NORMALITY, THE DISPLAY WILL OPERATE NORMALLY.
- 13.6.3 ADJUST THE LC DRIVING VOLTAGE TO OBTAIN THE OPTIMUM CONTRAST .
- 13.6.4 POWER ON SEQUENCE INPUT SIGNALS SHOULD NOT BE SUPPLIED TO LCD MODULE BEFORE POWER SUPPLY VOLTAGE IS APPLIED AND REACHES THE SPECIFIED VALUE.
IF ABOVE SEQUENCE IS NOT FOLLOWED , CMOS LSIS OF LCD MODULES MAY BE DAMAGED DUE TO LATCH - UP PROBLEM.
- 13.6.5 NOT ALLOWED TO INFLICT ANY EXTERNAL STRESS AND TO CAUSE ANY MECHANICAL INTERFERENCE ON THE BENDING AREA OF FPC DURING THE TAIL BENDING BACKWARDS!
DO NOT STRESS FPC AND IC ON THE MODULE!

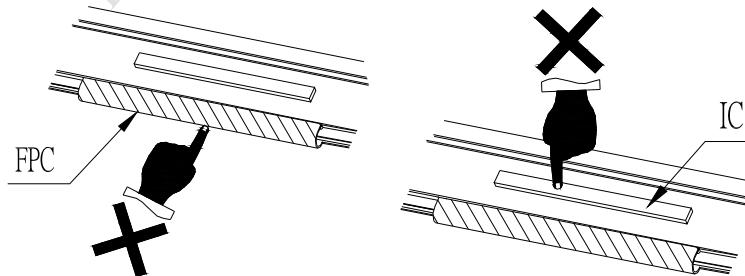

13.7 NOTICE

- 13.7.1 USE A GROUNDED SOLDERING IRON WHEN SOLDERING CONNECTOR I/O TERMINALS . FOR SOLDERING OR REPAIRING, TAKE PRECAUTION AGAINST THE TEMPERATURE OF THE SOLDERING IRON AND THE SOLDERING TIME TO PREVENT PEELING OFF THE THROUGH-HOLE-PAD.
- 13.7.2 DO NOT DISASSEMBLE . EDT SHALL NOT BE HELD RESPONSIBLE IF THE MODULE IS DISASSEMBLED AND UPON THE REASSEMBLY THE MODULE FAILED.
- 13.7.3 DO NOT CHARGE STATIC ELECTRICITY, AS THE CIRCUIT OF THIS MODULE CONTAINS CMOS LSIS. A WORKMAN'S BODY SHOULD ALWAYS BE STATIC-PROTECTED BY USE OF AN ESD STRAP. WORKING CLOTHES FOR SUCH PERSONNEL SHOULD BE OF STATIC-PROTECTED MATERIAL.
- 13.7.4 ALWAYS GROUND THE ELECTRICALLY-POWERED DRIVER BEFORE USING IT TO INSTALL THE LCD MODULE. WHILE CLEANING THE WORK STATION BY VACUUM CLEANER, DO NOT BRING THE SUCKING MOUTH NEAR THE MODULE ; STATIC ELECTRICITY OF THE ELECTRICALLY-POWERED DRIVER OR THE VACUUM CLEANER MAY DESTROY THE MODULE.
- 13.7.5 DON'T GIVE EXTERNAL SHOCK.
- 13.7.6 DON'T APPLY EXCESSIVE FORCE ON THE SURFACE.
- 13.7.7 LIQUID IN LCD IS HAZARDOUS SUBSTANCE. MUST NOT LICK AND SWALLOW.
WHEN THE LIQUID IS ATTACH TO YOUR, SKIN, CLOTH ETC. WASH IT OUT THOROUGHLY AND IMMEDIATELY.
- 13.7.8 DON'T OPERATE IT ABOVE THE ABSOLUTE MAXIMUM RATING.
- 13.7.9 STORAGE IN A CLEAN ENVIRONMENT, FREE FROM DUST, ACTIVE GAS, AND SOLVENT.
- 13.7.10 STORE WITHOUT ANY PHYSICAL LOAD.
- 13.7.11 REWIRING: NO MORE THAN 3 TIMES.