

EXAMINED BY :	EMERGING DISPLAY TECHNOLOGIES CORPORATION	FILE NO . CAS-0009793
Lucica Lu		ISSUE : FEB.07, 2025
APPROVED BY:		TOTAL PAGE : 26
Vincent Wn		VERSION : 1

CUSTOMER ACCEPTANCE SPECIFICATIONS

MODEL NO. :

ET043013DDBA

(RoHS)

FOR MESSRS : _____

CUSTOMER'S APPROVAL

DATE :

BY :

EMERGING DISPLAY
TECHNOLOGIES CORPORATION

MODEL NO.	VERSION	PAGE
ET043013DDBA	1	0-1

RECORDS OF REVISION

DOC . FIRST ISSUE

FEB.07, 2025

DATE	REVISED PAGE NO.	SUMMARY
<p style="text-align: center;"><i>CONFIDENTIAL</i> <i>Authorized for</i> <i>Emerging Display Technologies Corporation Only.</i> <i>Do not distribute without authorization.</i></p>		

TABLE OF CONTENTS

NO.	ITEM	PAGE
1.	GENERAL SPECIFICATIONS -----	1
2.	MECHANICAL SPECIFICATIONS -----	1
3.	ABSOLUTE MAXIMUM RATINGS -----	2
4.	ELECTRICAL CHARACTERISTICS -----	3
5.	TIMING CHARACTERISTICS -----	4 ~ 9
6.	OPTICAL CHARACTERISTICS -----	10 , 11
7.	OUTLINE DIMENSIONS -----	12
8.	BLOCK DIAGRAM -----	13
9.	DETAIL DRAWING OF DOT MATRIX -----	14
10.	INTERFACE SIGNALS -----	15
11.	POWER SUPPLY -----	16
12.	INSPECTION CRITERIA -----	17 ~ 23
13.	RELIABILITY TEST -----	24
14.	CAUTION -----	25 , 26

CONFIDENTIAL
Authorized for Emerging Display Technologies Corporation Only.
Do not distribute without authorization.

1. GENERAL SPECIFICATIONS

1.1 DATA SHEETS FOR CONTROLLER/DRIVER

PLEASE REFER TO :

SITRONIX ST7282A

1.2 MATERIAL SAFETY DESCRIPTION

ASSEMBLIES SHALL COMPLY WITH EUROPEAN ROHS REQUIREMENTS, INCLUDING PROHIBITED MATERIALS/COMPONENTS CONTAINING LEAD, MERCURY, CADMIUM, HEXAVALENT CHROMIUM, POLYBROMINATED BIPHENYLS (PBB) AND POLYBROMINATED DIPHENYL ETHERS (PBDE), BIS(2-ETHYLHEXYL) PHTHALATE (DEHP), BUTYL BENZYL PHTHALATE (BBP), DIBUTYL PHTHALATE (DBP), DIISOBUTYL PHTHALATE (DIBP).

2. MECHANICAL SPECIFICATIONS

(1) DIAGONALS	-----	4.3 inch
(2) NUMBER OF DOTS	-----	480(RGB)W * 272H DOTS
(3) MODULE SIZE	-----	105.5W * 67.2H * 2.8D mm (NOT INCLUDED FPC)
(4) VIEWING AREA	-----	99W * 56H mm
(5) ACTIVE AREA	-----	95.04W * 53.856H mm
(6) DOT SIZE	-----	0.066W * 0.198H mm
(7) PIXEL PITCH	-----	0.198W * 0.198H mm
(8) LCD TYPE	-----	TFT , IPS , TRANSMISSIVE , NORMALLY BLACK
(9) COLOR	-----	16.7M
(10) VIEWING DIRECTION	-----	SUPER WIDE VIEW
(11) BACKLIGHT	-----	LED , COLOR : WHITE
(12) INTERFACE MODE	-----	RGB 24 BIT PARALLEL (SYNC/DE/SYNC-DE MODE)
(13) WEIGHT	-----	39g

3. ABSOLUTE MAXIMUM RATINGS

3.1 LCD MODULE ELECTRICAL ABSOLUTE MAXIMUM RATINGS

ITEM	SYMBOL	MIN.	MAX.	UNIT	REMARK
POWER SUPPLY VOLTAGE	VDD-VSS	-0.3	4.0	V	—
POWER SUPPLY VOLTAGE FOR LED DRIVER	VBL+-VBL-	11.4	12.6	V	
STATIC ELECTRICITY	—	—	—	V	NOTE (1)

NOTE (1) : LCM SHOULD BE GROUND DURING LCM HANDLING.

3.2 ENVIRONMENTAL ABSOLUTE MAXIMUM RATINGS

ITEM	OPERATING		STORAGE		REMARK
	MIN.	MAX.	MIN.	MAX.	
AMBIENT TEMPERATURE	-20°C	70°C	-30°C	80°C	NOTE (1), (2), (3), (4)
HUMIDITY	NOTE (2)		NOTE (2)		WITHOUT CONDENSATION
CORROSIVE GAS	NOT ACCEPTABLE		NOT ACCEPTABLE		

NOTE (1) : THE ABSOLUTE MAXIMUM RATINGS OF THIS PRODUCT SHOULD NOT BE EXCEEDED AT ANY TIME. IF THESE RATINGS ARE EXCEEDED, THE PRODUCT'S PERFORMANCE IS NOT GUARANTEED AND THE PRODUCT MAY EXPERIENCE PERMANENT DAMAGE.

NOTE (2) : Ta ≤ 60°C : 90%RH MAX. (96HRS MAX.)

Ta > 60°C : ABSOLUTE HUMIDITY MUST BE LOWER THAN THE HUMIDITY OF 90%RH AT 60°C. (96HRS MAX.)

NOTE (3) : BACKGROUND COLOR CHANGES SLIGHTLY DEPENDING ON AMBIENT TEMPERATURE THIS PHENOMENON IS REVERSIBLE.

NOTE (4) : WHEN THE LCD MODULE IS OPERATED AT A HIGHER AMBIENT TEMPERATURE THAN 60°C, THE PWM DUTY CYCLE OF THE LED BACKLIGHT SHOULD BE ADJUSTED TO BE LESS THAN TBD. IF THE MODULE IS OPERATED AT A HIGHER DUTY CYCLE THAN TBD, THEN THERE IS A POSSIBILITY OF DISTORTION AND IRREGULARITY OF THE PICTURE DUE TO LIQUID CRYSTAL BEHAVIOR.

4. ELECTRICAL CHARACTERISTICS

Ta = 25 °C

ITEM	SYMBOL	CONDITION	MIN.	TYP.	MAX.	UNIT	REMARK
POWER SUPPLY VOLTAGE	VDD-VSS	—	3.15	3.30	3.45	V	
POWER SUPPLY VOLTAGE FOR LED DRIVER	VBL+-VBL-	—	11.4	12.0	12.6	V	
POWER SUPPLY CURRENT	IDD	VDD-VSS =3.30V	—	30	40	mA	NOTE (1)
POWER SUPPLY CURRENT FOR LED DRIVER	IBL	VBL+-VBL- =12.0V LED B/L=ON	—	100	120	mA	
LOGIC HIGH INPUT VOLTAGE	V _{IH}	—	0.7*VDD	—	VDD	V	NOTE (2)
LOGIC LOW INPUT VOLTAGE	V _{IL}	—	VSS	—	0.3*VDD	V	NOTE (2)
LOGIC HIGH OUTPUT VOLTAGE	V _{OH}	—	VDD-0.4	—	VDD	V	
LOGIC LOW OUTPUT VOLTAGE	V _{OL}	—	VSS	—	VSS+0.4	V	
LED LIFE TIME	—	IF=20mA (PER LED)	30K	—	—	HRS	NOTE (4) NOTE (5)

NOTE (1) : THE DISPLAY PATTERN IS ALL “WHITE”.

NOTE (2) : APPLIED TO TERMINALS B7~B0, G7~G0, R7~R0, DCLK, HSYNC, VSYNC, DE.

NOTE (3) : INTERNAL CIRCUIT DIAGRAM OF BACKLIGHT

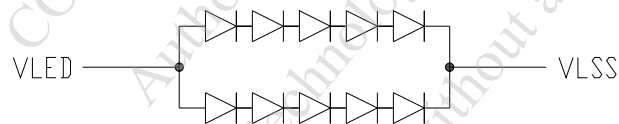

NOTE (4) : CONDITIONS; Ta=25 °C, CONTINUOUS LIGHTING

NOTE (5) : DEFINITIONS OF LIFE TIME :

LCM LUMINANCE BECOMES HALF OF THE INITIAL VALUE.

5. TIMING CHARACTERISTICS

5.1 LCD MODULE AC ELECTRICAL CHARACTERISTICS

5.1.1 SYNC MODE

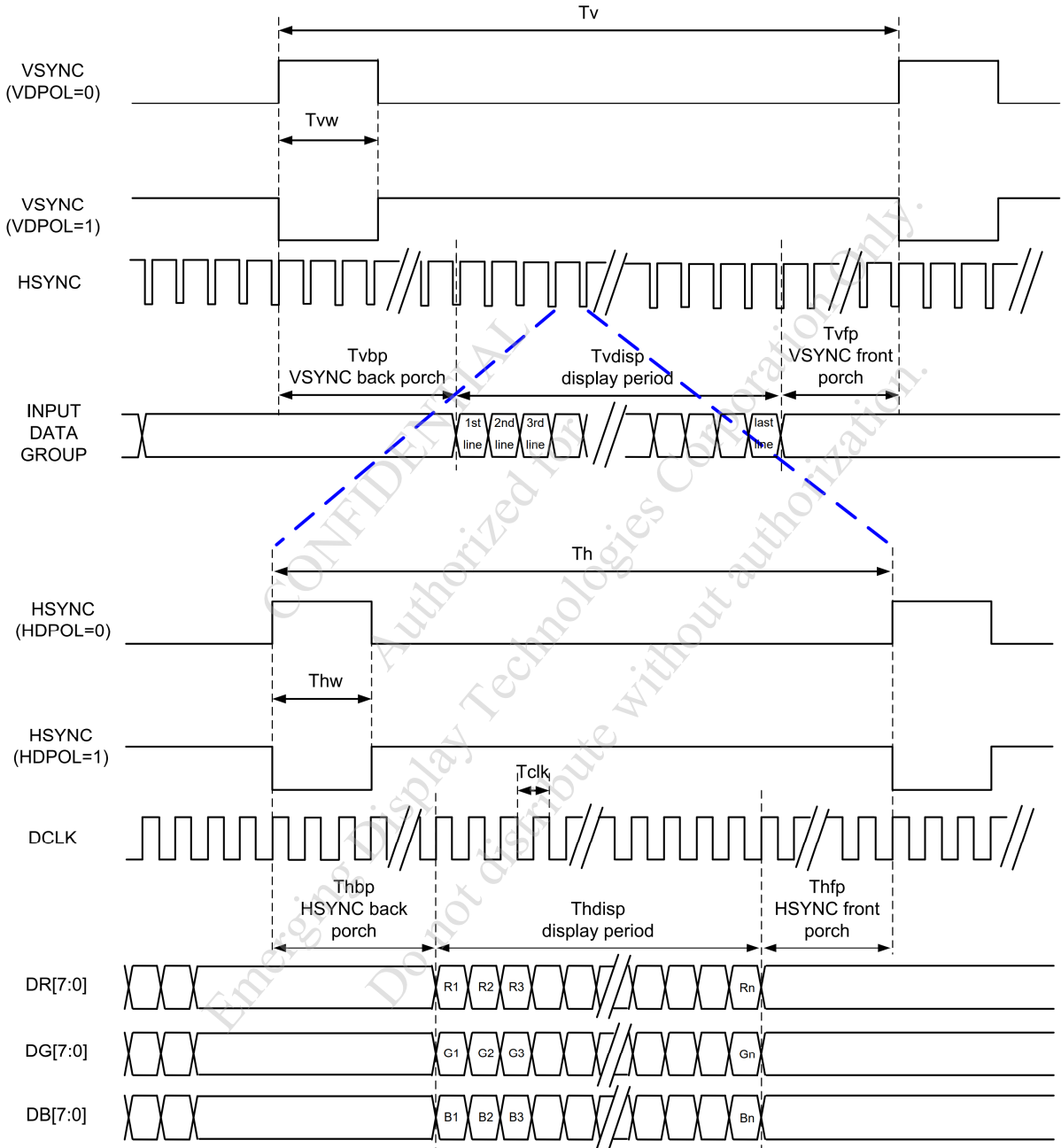

5.1.2 DE MODE

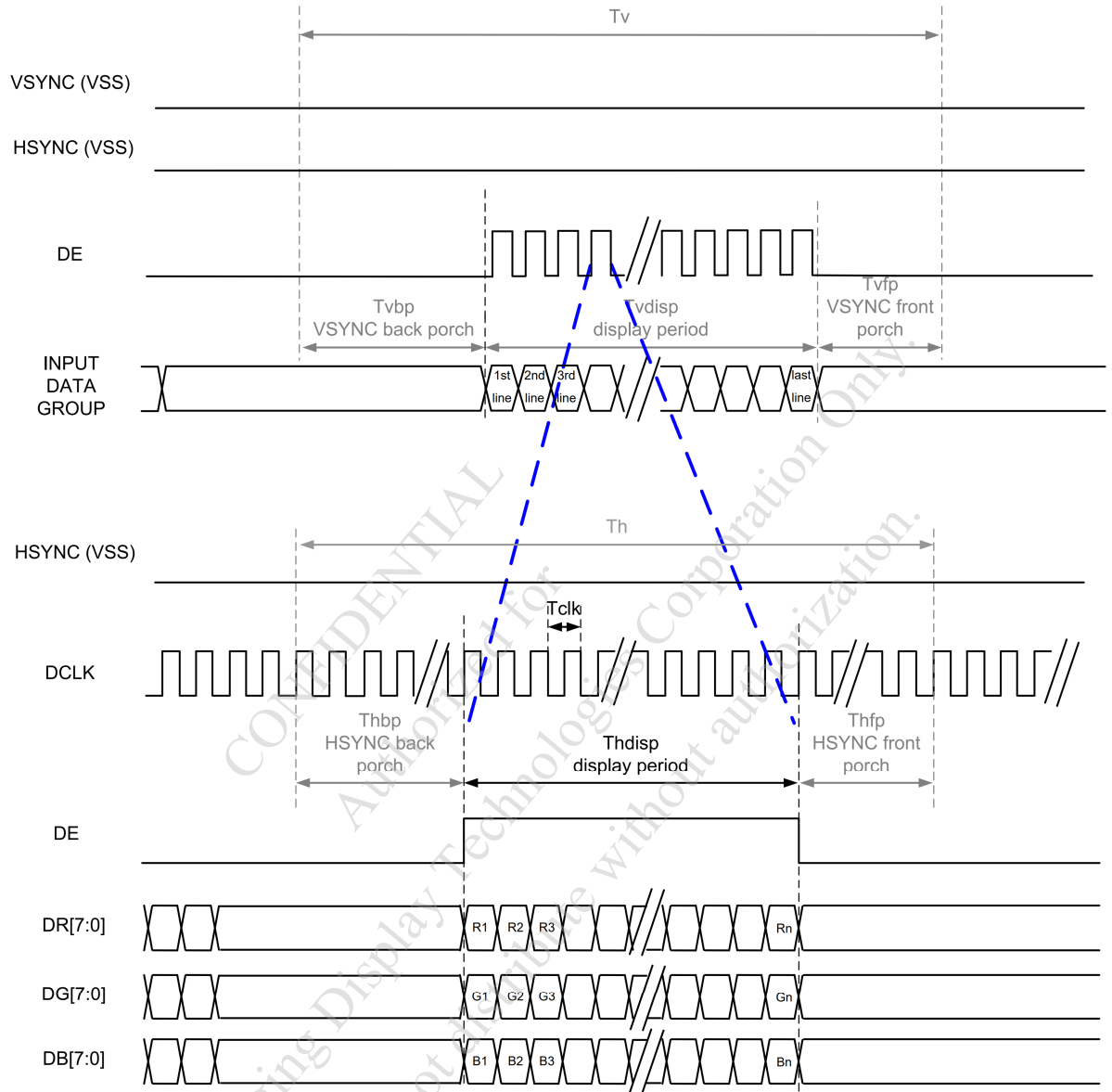

5.1.3 SYNC-DE MODE

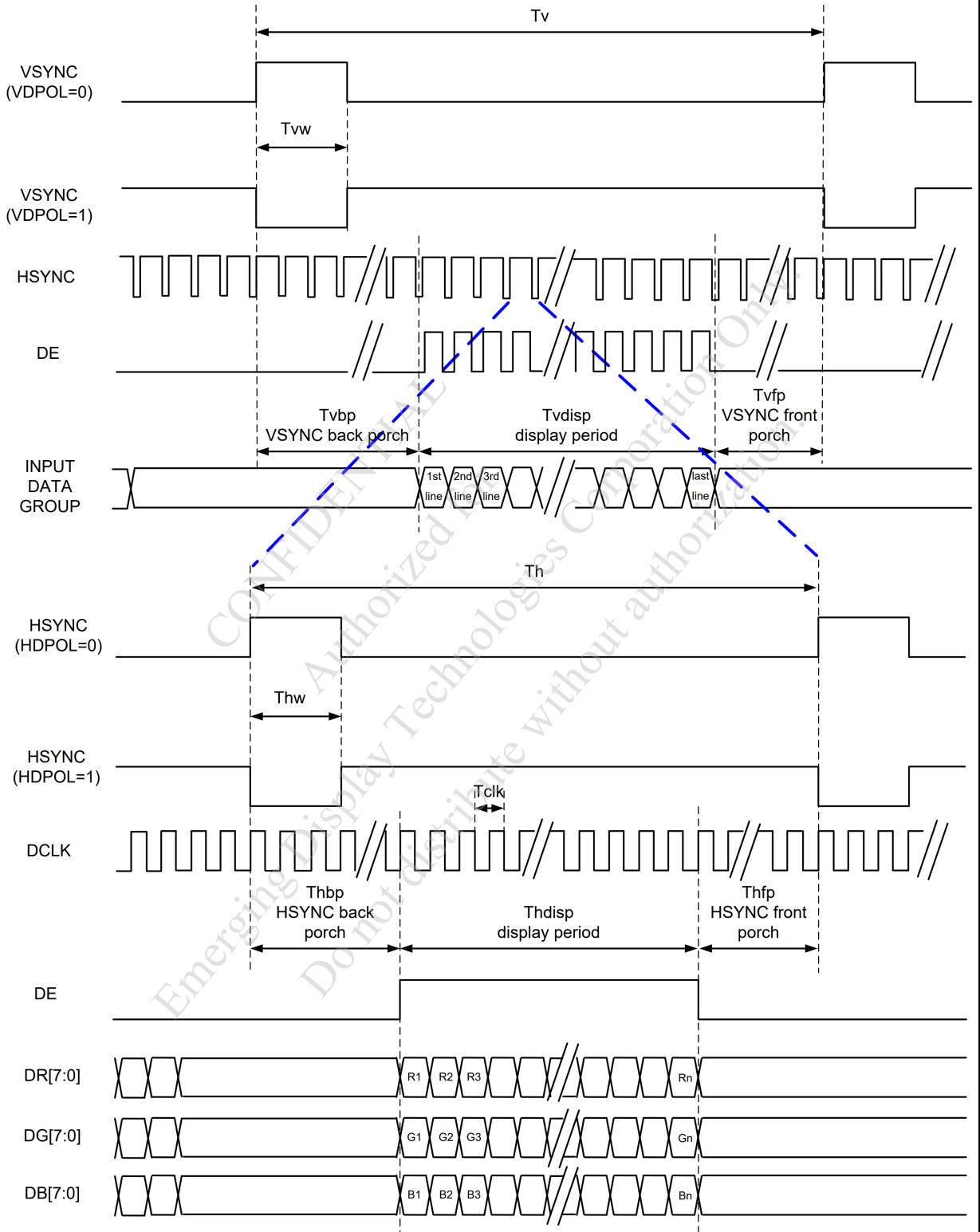

5.1.4 PARALLEL 24 BIT RGB INPUT TIMING TABLE

PARALLEL 24-BIT RGB INPUT TIMING

Ta=25°C

ITEM	SYMBOL	MIN.	TYP.	MAX.	UNIT	REMARK	
DCLK FREQUENCY	Fclk	8	9	12	MHz		
DCLK PERIOD	Tclk	83	111	125	ns		
HSYNC	PERIOD TIME	Th	485	531	598	DCLK	
	DISPLAY PERIOD	Thdisp	—	480	—	DCLK	
	BACK PORCH	Thbp	3	43	43	DCLK	BY H_BLANKING SETTING
	FRONT PORCH	Thfp	2	8	75	DCLK	
	PULSE WIDTH	Thw	2	4	75	DCLK	
VSYNC	PERIOD TIME	Tv	276	292	321	HSYNC	
	DISPLAY PERIOD	Tvdisp	—	272	—	HSYNC	
	BACK PORCH	Tvbp	2	12	12	HSYNC	BY V_BLANKING SETTING
	FRONT PORCH	Tvfp	2	8	37	HSYNC	
	PULSE WIDTH	Tvw	2	4	37	HSYNC	

NOTE: IT IS NECESSARY TO KEEP Tvbp =12 AND Thbp =43 IN SYNC MODE. DE MODE IS UNNECESSARY TO KEEP IT.

CONFIDENTIAL
Authorized for
Emerging Display Technologies Corporation only.
Do not distribute without authorization.

5.1.5 SYSTEM BUS TIMING FOR RGB INTERFACE

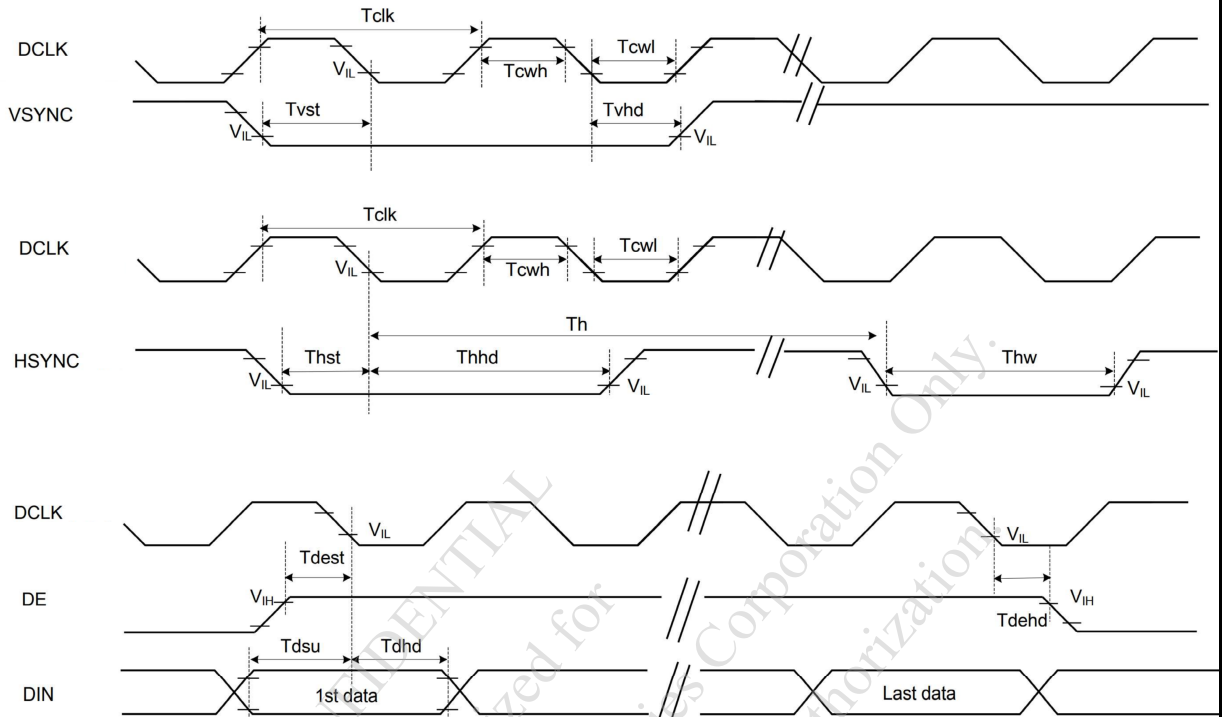

ITEM	SYMBOL	MIN.	TYP.	MAX.	UNIT	CONDITIONS
CLK PULSE DUTY	T_{cwl}	40	50	60	%	
HSYNC WIDTH	T_{hw}	2	—	—	DCLK	
HSYNC PERIOD	T_h	55	60	65	us	
VSYNC SETUP TIME	T_{vst}	12	—	—	ns	
VSYNC HOLD TIME	T_{vhhd}	12	—	—	ns	
HSYNC SETUP TIME	T_{hst}	12	—	—	ns	
HSYNC HOLD TIME	T_{hhhd}	12	—	—	ns	
DATA SETUP TIME	T_{dsu}	12	—	—	ns	
DATA HOLD TIME	T_{dhd}	12	—	—	ns	
DE SETUP TIME	T_{dest}	12	—	—	ns	
DE HOLD TIME	T_{dehd}	12	—	—	ns	

5.2 LCD MODULE POWER ON-OFF TIMING SEQUENCE

5.2.1 POWER ON TIMING SEQUENCE

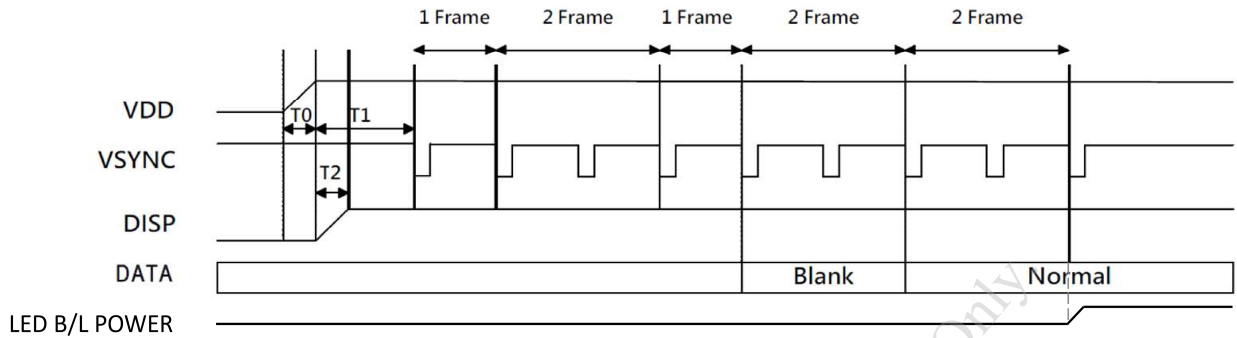

ITEM	DESCRIPTION	MIN. TIME
T0	DETERMINED BY THE EXTERNAL POWER	
T1	TIME FROM STABLE VDD, SET-UP TO THE FIRST VSYNC	T1=0
T2	TIME FROM STABLE VDD SET-UP TO DISP ASSERTED	T2=0

NOTE : RECOMMEND THE LCM POWER ON RISE TIME T0= 0~ 1ms.

5.2.2 POWER OFF TIMING SEQUENCE

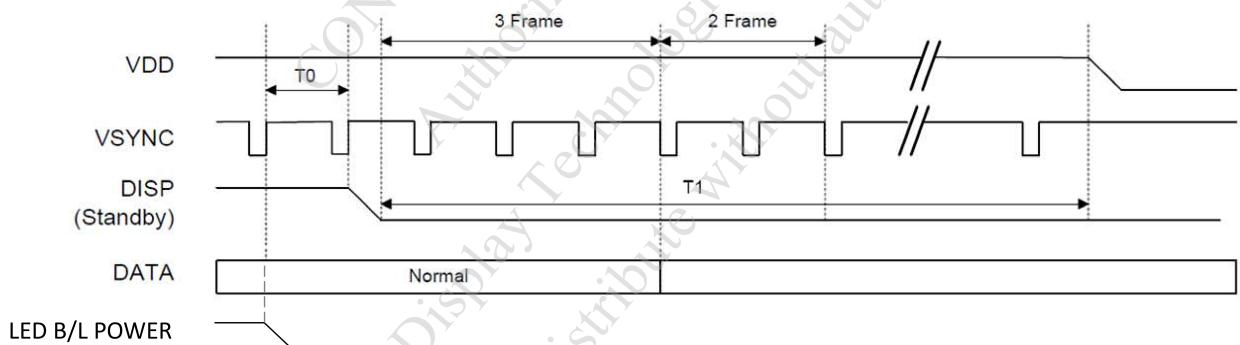

ITEM	DESCRIPTION	MIN. TIME
T0	TIME FROM BACKLIGHT POWER OFF TO DISP="L"	1*Frame
T1	TIME FROM DISP="L" TO LCM POWER OFF	5*Frame

6. OPTICAL CHARACTERISTICS (NOTE 1)

6.1 OPTICAL CHARACTERISTICS

Ta = 25°C

ITEM	SYMBOL	CONDITION	MIN.	TYP.	MAX.	UNIT	REMARK	
VIEWING ANGLE	θ_{y+}	CR ≥ 10	$\theta_x=0^\circ$	80	85	—	deg.	NOTE (2) NOTE (3)
	θ_{y-}			80	85	—		
	θ_{x+}		$\theta_y=0^\circ$	80	85	—		
	θ_{x-}			80	85	—		
CONTRAST RATIO (CENTER)	CR	$\theta_x=0^\circ, \theta_y=0^\circ$	800	1000	—	—	NOTE (3)	
RESPONSE TIME	tr (rise)+ tf (fall)	$\theta_x=0^\circ, \theta_y=0^\circ$	—	30	35	msec	NOTE (4)	
COLOR CHROMATICITY (CENTER)	WHITE	Wx	$\theta_x=0^\circ, \theta_y=0^\circ$ VDD-VSS=3.30V VBL+-VBL- =12.0V	0.25	0.30	0.35	—	NOTE (5)
		Wy		0.28	0.33	0.38		
	RED	Rx		0.54	0.59	0.64	—	
		Ry		0.27	0.32	0.37		
	GREEN	Gx		0.30	0.35	0.40	—	
		Gy		0.54	0.59	0.64		
	BLUE	Bx		0.10	0.15	0.20	—	
		By		0.06	0.11	0.16		
THE BRIGHTNESS OF MODULE (CENTER)	B		800	1000	—	cd/m ²	NOTE (6)	
THE BRIGHTNESS OF UNIFORMITY	—		70	—	—	%	NOTE (7)	

NOTE (1) : TEST CONDITION :

AFTER STABILIZING AND LEAVING THE PANEL ALONE AT A GIVEN TEMPERATURE FOR 30 MINUTES. MEASUREMENT SHOULD BE EXECUTED IN A STABLE, WINDLESS, AND DARK ROOM.

THE MEASUREMENT CRITERIA AND CONDITION FOR EITHER BM-5 OR CA-210 OR EQUIVALENT LUMINANCE METER IS BASED ON THE EQUIPMENT'S MANUAL.

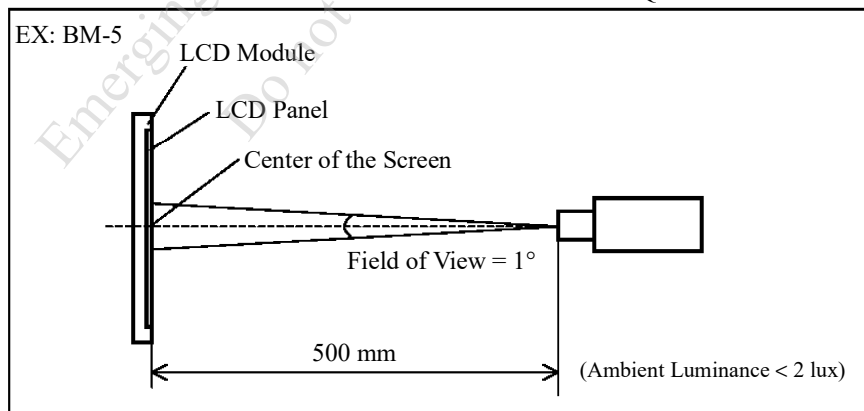

NOTE (2) : DEFINITION OF VIEWING ANGLE :

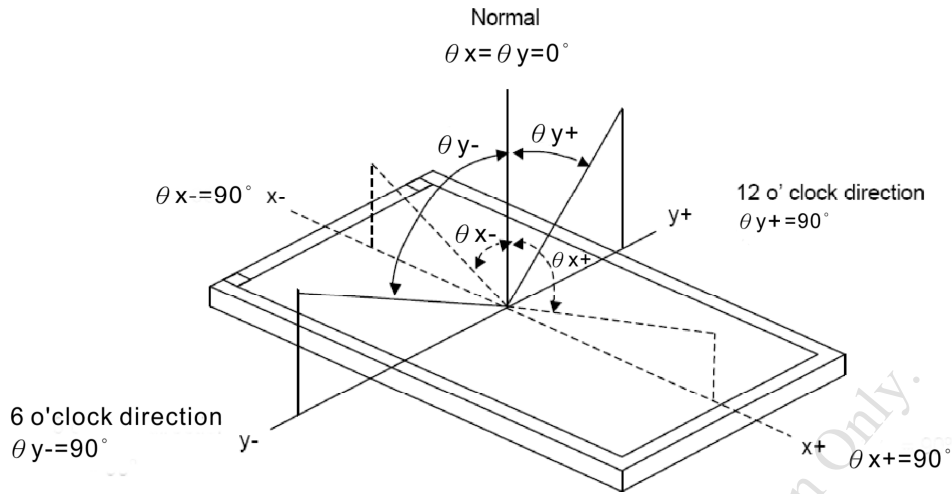

NOTE (3) : DEFINITION OF CONTRAST RATIO (CR) :
MEASURED AT THE CENTER POINT OF MODULE

$$\text{CONTRAST RATIO(CR)} = \frac{\text{BRIGHTNESS MEASURED WHEN LCD IS AT "WHITE STATE"}}{\text{BRIGHTNESS MEASURED WHEN LCD IS AT "BLACK STATE"}}$$

NOTE (4) : DEFINITION OF RESPONSE TIME : T_R AND T_F
THE FIGURE BELOW IS THE OUTPUT SIGNAL OF THE PHOTO DETECTOR.

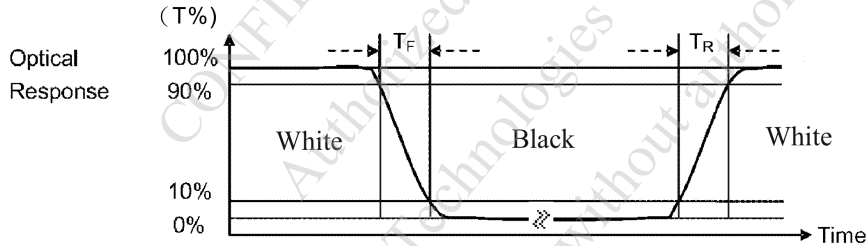

NOTE (5) : DEFINITION OF COLOR CHROMATICITY

(a) 100% RGB PIXEL DATA TRANSMISSION WHEN ALL THE INPUT TERMINALS OF MODULE ARE ELECTRICALLY POWERED ON.

(b) MEASURED AT THE CENTER POINT OF MODULE

NOTE (6) : MEASURED THE BRIGHTNESS OF WHITE STATE AT CENTER POINT.

NOTE (7) : (a) DEFINITION OF BRIGHTNESS UNIFORMITY

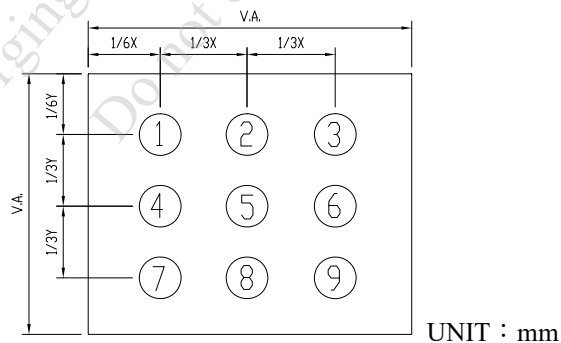

(b) THE BRIGHTNESS UNIFORMITY CALCULATING METHOD

$$\text{UNIFORMITY} : \frac{\text{MINIMUM BRIGHTNESS}}{\text{MAXIMUM BRIGHTNESS}} * 100\%$$

7. OUTLINE DIMENSIONS

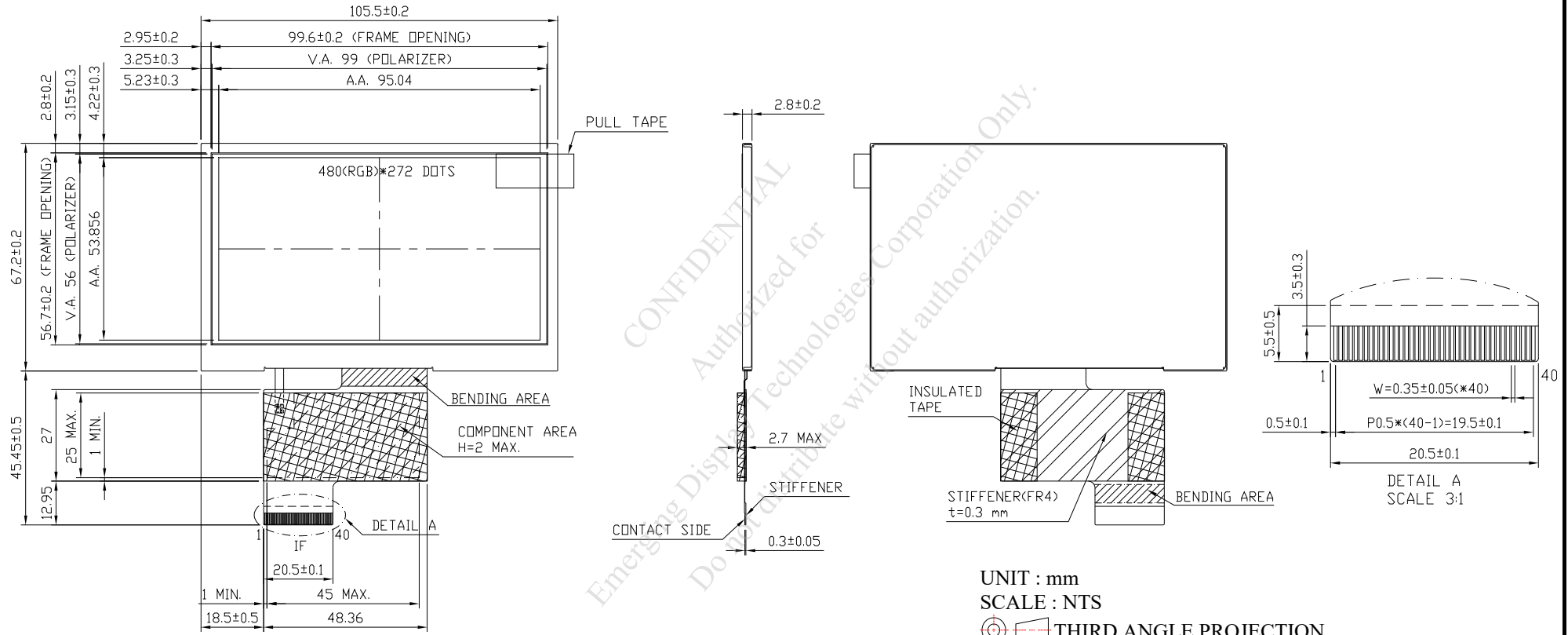

UNIT : mm

SCALE : NTS

THIRD ANGLE PROJECTION

NOT SPECIFIED TOLERANCE IS ±0.3mm

NOTE :

1.RECOMMEND MATCH CONNECTOR

KYOCERA : 04 6240 040 SERIES.

2.FPC BENDING RADIUS SHOULD BE MORE THAN 1.0 mm.

8. BLOCK DIAGRAM

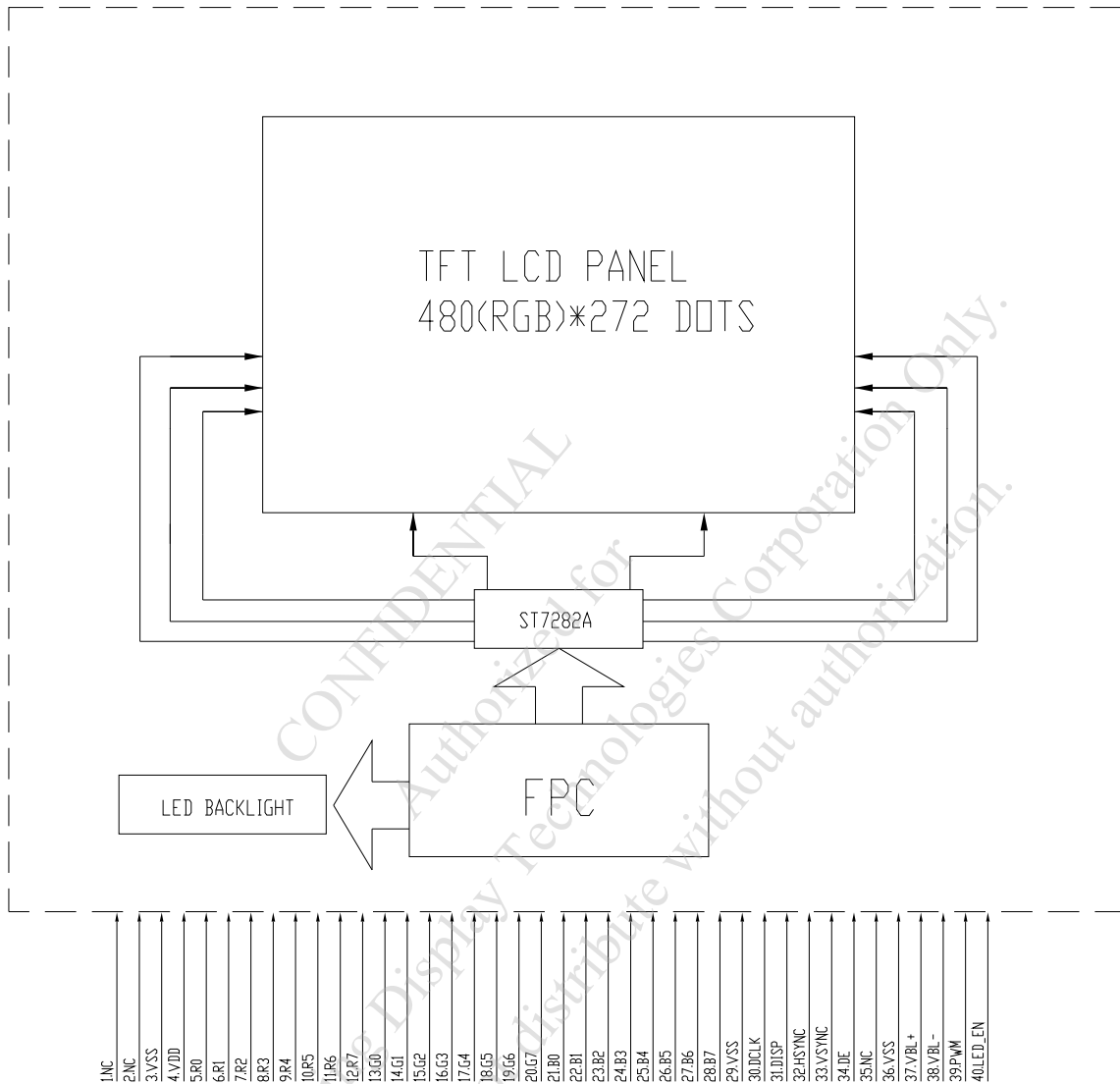

9. DETAIL DRAWING OF DOT MATRIX

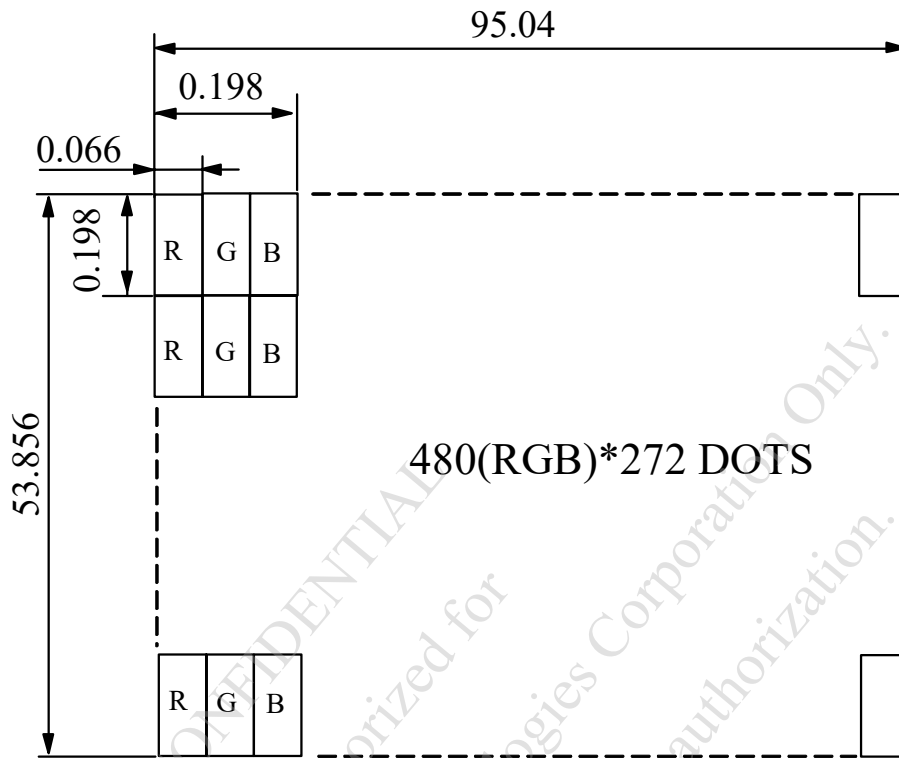

UNIT : mm
SCALE : NTS
NOT SPECIFIED TOLERANCE IS ± 0.1
DOTS MATRIX TOLERANCE IS ± 0.01

CONFIDENTIAL
Authorized for Emerging Display Technologies Corporation Only.
Do not distribute without authorization.

10. INTERFACE SIGNALS

PIN NO.	SYMBOL	FUNCTION
1	NC	NON CONNECTION
2	NC	NON CONNECTION
3	VSS	GROUND
4	VDD	POWER SUPPLY VOLTAGE
5	R0	RED DATA SIGNAL (LSB)
6	R1	RED DATA SIGNAL
7	R2	RED DATA SIGNAL
8	R3	RED DATA SIGNAL
9	R4	RED DATA SIGNAL
10	R5	RED DATA SIGNAL
11	R6	RED DATA SIGNAL
12	R7	RED DATA SIGNAL (MSB)
13	G0	GREEN DATA SIGNAL (LSB)
14	G1	GREEN DATA SIGNAL
15	G2	GREEN DATA SIGNAL
16	G3	GREEN DATA SIGNAL
17	G4	GREEN DATA SIGNAL
18	G5	GREEN DATA SIGNAL
19	G6	GREEN DATA SIGNAL
20	G7	GREEN DATA SIGNAL (MSB)
21	B0	BLUE DATA SIGNAL (LSB)
22	B1	BLUE DATA SIGNAL
23	B2	BLUE DATA SIGNAL
24	B3	BLUE DATA SIGNAL
25	B4	BLUE DATA SIGNAL
26	B5	BLUE DATA SIGNAL
27	B6	BLUE DATA SIGNAL
28	B7	BLUE DATA SIGNAL (MSB)
29	VSS	GROUND
30	DCLK	CLOCK SIGNAL; LATCHING DATA AT THE FALLING EDGE
31	DISP	DISPLAY CONTROL / STANDBY MODE SELECTION. DISP="LOW": STANDBY; DISP="HIGH" : NORMAL DISPLAY
32	HSYNC	HORIZONTAL SYNC SIGNAL
33	VSYNC	VERTICAL SYNC SIGNAL
34	DE	DATA INPUT ENABLE. ACTIVE HIGH TO ENABLE THE DATA INPUT.
35	NC	NON CONNECTION
36	VSS	GROUND
37	VBL+	POWER SUPPLY VOLTAGE FOR LED DRIVER CIRCUIT
38	VBL-	GROUND
39	PWM	DIMMING CONTROL INPUT FOR BACKLIGHGT.DO NOT ALLOW THIS PIN TO FLOAT.
40	LED_EN	LED ENABLE PIN

RGB MODE SELECTION TABLE	DCLK	HSYNC	VSYNC	DE
SYNC-DE MODE	INPUT	INPUT	INPUT	INPUT
SYNC MODE	INPUT	INPUT	INPUT	VSS
DE MODE	INPUT	VSS	VSS	INPUT

NOTE: "INPUT" MEANS THESE SIGNALS ARE DRIVEN BY HOST SIDE.

11. POWER SUPPLY

11.1 POWER SUPPLY FOR LCM

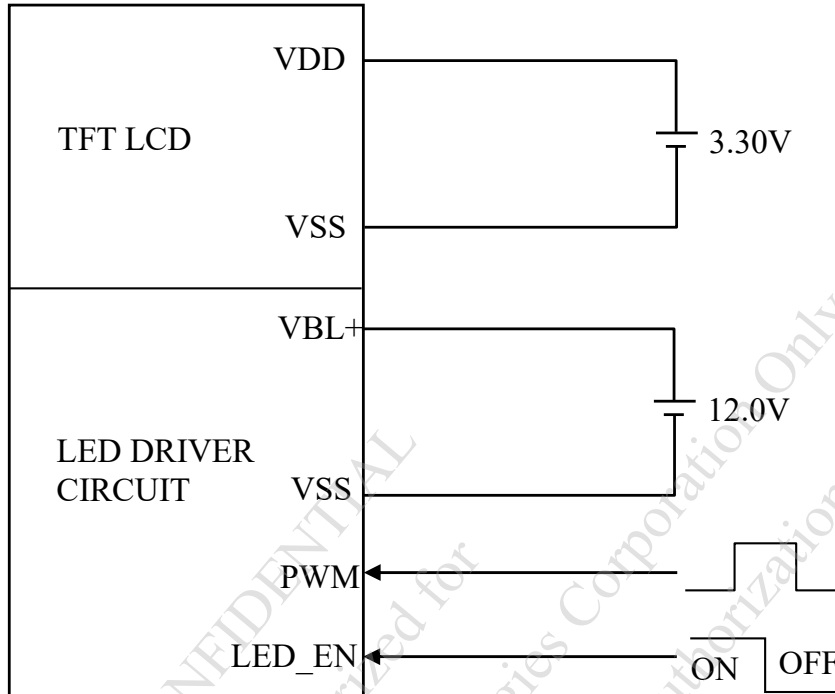

NOTE (1) : ADJUST THE PWM SIGNAL IN ORDER TO CONTROL LED BACKLIGHT'S BRIGHTNESS. THE HIGHER THE DUTY CYCLE, THE HIGHER THE BRIGHTNESS

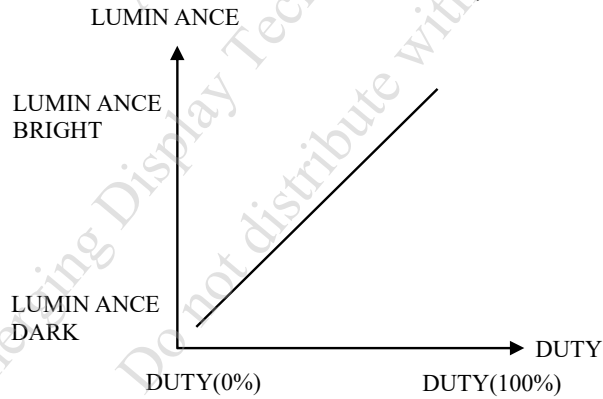

NOTE (2) : OPERATION FREQUENCY : 15±5KHz

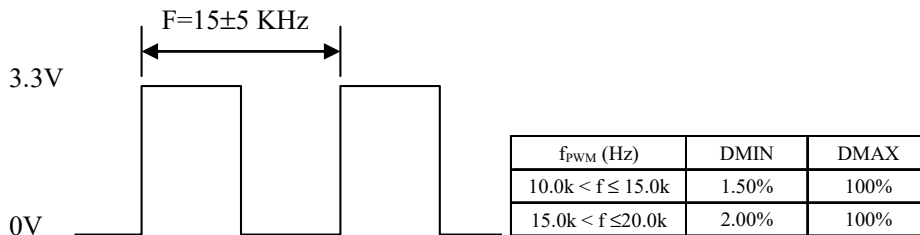

12. INSPECTION CRITERIA

12.1 APPLICATION

THIS INSPECTION STANDARD IS TO BE APPLIED TO THE LCD MODULE DELIVERED FROM EMERGING DISPLAY TECHNOLOGIES CORP.(E.D.T) TO CUSTOMERS

12.2 INSPECTION CONDITIONS

12.2.1 (1)OBSERVATION DISTANCE : 45±5cm

(2)VIEWING ANGLE : ±45°

±45° (FOR SECTION WITHIN VIEWING AREA), REFER TO FIG.A
90° (FOR SECTION OUTSIDE OF VIEWING AREA), REF TO FIG.B
PERPENDICULAR TO MODULE SURFACE

VIEWING ANGLE SHOULD BE SMALLER THAN 45°



THE INSPECTION CRITERIA IS ACCORDING TO LINE OF SIGHT. INSPECTION SHALL BE MADE WITHIN THE HALF SECTION OF THE VIEWING CONE GENERATED BY LINE SEGMENT OF 45° WITH RESPECT TO THE VERTICAL AXIS FROM CENTER VERTEX OF LCD, THE FLUORESCENT LAMP AND THE CONE AXIS MUST BE PERPENDICULAR TO THE LCD SURFACE.

IF THE DEFECTS ARE OUTSIDE OF VIEWING AREA, IT SHALL BE INSPECTED BY 90° WITH RESPECT TO THE VERTICAL AXIS FROM EDGE OF VIEWING AREA.

12.2.2 ENVIRONMENT CONDITIONS :

AMBIENT TEMPERATURE		25±5°C
AMBIENT HUMIDITY		65 ± 20%RH
AMBIENT ILLUMINATION	COSMETIC INSPECTION	600 ~ 800 lux
	FUNCTIONAL INSPECTION	300~500 lux
INSPECTION TIME		10 secs

12.2.3 INSPECTION LOT

QUANTITY PER DELIVERY LOT FOR EACH MODEL

12.2.4 A SAMPLING INSPECTION SHALL BE MADE ACCORDING TO THE FOLLOWING PROVISIONS TO JUDGE THE ACCEPTABILITY

(a)APPLICABLE STANDARD :

ANSI/ ASQ Z1.4 NORMAL INSPECTION LEVEL II

(b)AQL : MAJOR DEFECT : AQL 0.65

MINOR DEFECT : AQL 1.0

12.3 INSPECTION STANDARDS

12.3.1 VISUAL DEFECTS CLASSIFICATION

TYPE OF DEFECT	INSPECTION ITEM	DEFECT FEATURE	AQL
MAJOR DEFECT	1.DISPLAY ON	<ul style="list-style-type: none"> • DEFECT TO MISS SPECIFIED DISPLAY FUNCTION, FOR ALL AND SPECIFIED DOTS EX: DISCONNECTION, SHORT CIRCUIT ETC 	0.65
	2.BACKLIGHT	<ul style="list-style-type: none"> • NO LIGHT • FLICKERING AND OTHER ABNORMAL ILLUMINATION 	
	3.DIMENSIONS	<ul style="list-style-type: none"> • SUBJECT TO INDIVIDUAL ACCEPTANCE SPECIFICATIONS 	
MINOR DEFECT	1.DISPLAY ZONE	<ul style="list-style-type: none"> • BLACK/WHITE SPOT • BUBBLES ON POLARIZER • NEWTON RING • BLACK/WHITE LINE • SCRATCH • CONTAMINATION • LEVER COLOR SPREAD 	1.0
	2.BEZEL ZONE	<ul style="list-style-type: none"> • STAINS • SCRATCHES • FOREIGN MATTER 	
	3.SOLDERING	<ul style="list-style-type: none"> • INSUFFICIENT SOLDER • SOLDERED IN INCORRECT POSITION • CONVEX SOLDERING SPOT • SOLDER BALLS • SOLDER SCRAPS 	
	4.DISPLAY ON (ALL ON)	<ul style="list-style-type: none"> • LIGHT LINE 	

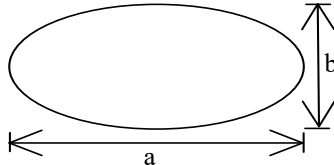

12.3.2 MODULE DEFECTS CLASSIFICATION

NO.	ITEM	CRITERIA												
1	DISPLAY ON INSPECTION	1. INCORRECT PATTERN 2. MISSING SEGMENT 3. DIM SEGMENT 4. OPERATING VOLTAGE BEYOND SPEC												
2	OVERALL DIMENSIONS	1. OVERALL DIMENSION BEYOND SPEC												
3	DOT DEFECT	1. INSPECTION PATTERN: FULL WHITE, FULL BLACK, RED, GREEN AND BLUE SCREENS. 2. <table border="1" style="margin-left: 20px;"> <thead> <tr> <th>ITEMS</th> <th>ACCEPTABLE COUNT</th> </tr> </thead> <tbody> <tr> <td>BRIGHT DOT</td> <td>$N \leq 2$</td> </tr> <tr> <td>DARK DOT</td> <td>$N \leq 3$</td> </tr> <tr> <td>TOTAL BRIGHT AND DARK DOTS</td> <td>$N \leq 4$</td> </tr> </tbody> </table> <p>NOTE :</p> <p>1. THE DEFINITION OF DOT : THE SIZE OF A DEFECTIVE DOT OVER 1/2 OF WHOLE DOT IS REGARDED AS ONE DEFECTIVE DOT. THE BRIGHT DOT DEFECT MUST BE VISIBLE THROUGH A 5% ND FILTER</p> <p>2. BRIGHT DOT : DOTS APPEAR BRIGHT AND UNCHANGED IN SIZE IN WHICH LCD PANEL IS DISPLAYING UNDER BLACK PATTERN.</p> <p>3. DARK DOT : DOTS APPEAR DARK AND UNCHANGED IN SIZE IN WHICH LCD PANEL IS DISPLAYING UNDER PURE RED, GREEN, BLUE PICTURE.</p>	ITEMS	ACCEPTABLE COUNT	BRIGHT DOT	$N \leq 2$	DARK DOT	$N \leq 3$	TOTAL BRIGHT AND DARK DOTS	$N \leq 4$				
ITEMS	ACCEPTABLE COUNT													
BRIGHT DOT	$N \leq 2$													
DARK DOT	$N \leq 3$													
TOTAL BRIGHT AND DARK DOTS	$N \leq 4$													
4	FOREIGN BLACK/WHITE/BRIGHT LINE	<table border="1" style="margin-left: 20px;"> <thead> <tr> <th>LENGTH : L</th> <th>WIDTH : W</th> <th>PERMISSIBLE NO.</th> </tr> </thead> <tbody> <tr> <td>$L \leq 0.3$</td> <td>$W \leq 0.05$</td> <td>IGNORE</td> </tr> <tr> <td>$0.3 < L \leq 3.0$</td> <td>$0.05 < W \leq 0.1$</td> <td>4</td> </tr> <tr> <td>$3.0 < L$</td> <td>$0.1 < W$</td> <td>NONE</td> </tr> </tbody> </table> <p>WIDTH : W mm, LENGTH : L mm</p>	LENGTH : L	WIDTH : W	PERMISSIBLE NO.	$L \leq 0.3$	$W \leq 0.05$	IGNORE	$0.3 < L \leq 3.0$	$0.05 < W \leq 0.1$	4	$3.0 < L$	$0.1 < W$	NONE
LENGTH : L	WIDTH : W	PERMISSIBLE NO.												
$L \leq 0.3$	$W \leq 0.05$	IGNORE												
$0.3 < L \leq 3.0$	$0.05 < W \leq 0.1$	4												
$3.0 < L$	$0.1 < W$	NONE												
5	POLARIZER SCRATCHES	<table border="1" style="margin-left: 20px;"> <thead> <tr> <th>LENGTH : L</th> <th>WIDTH : W</th> <th>PERMISSIBLE NO.</th> </tr> </thead> <tbody> <tr> <td>$L \leq 0.3$</td> <td>$W \leq 0.05$</td> <td>IGNORE</td> </tr> <tr> <td>$0.3 < L \leq 3.0$</td> <td>$0.05 < W \leq 0.1$</td> <td>4</td> </tr> <tr> <td>$3.0 < L$</td> <td>$0.1 < W$</td> <td>NONE</td> </tr> </tbody> </table> <p>WIDTH : W mm, LENGTH : L mm</p>	LENGTH : L	WIDTH : W	PERMISSIBLE NO.	$L \leq 0.3$	$W \leq 0.05$	IGNORE	$0.3 < L \leq 3.0$	$0.05 < W \leq 0.1$	4	$3.0 < L$	$0.1 < W$	NONE
LENGTH : L	WIDTH : W	PERMISSIBLE NO.												
$L \leq 0.3$	$W \leq 0.05$	IGNORE												
$0.3 < L \leq 3.0$	$0.05 < W \leq 0.1$	4												
$3.0 < L$	$0.1 < W$	NONE												
6	FOREIGN MATTER \ BLACK SPOTS \ WHITE SPOTS \ DENT (INCLUDING LIGHT LEAKAGE DUE TO POLARIZING PLATES PINHOLES, ETC.)	<table border="1" style="margin-left: 20px;"> <thead> <tr> <th>AVERAGE DIAMETER (mm): D</th> <th>NUMBER OF PIECES PERMITTED</th> </tr> </thead> <tbody> <tr> <td>$D \leq 0.15$</td> <td>IGNORE</td> </tr> <tr> <td>$0.15 < D \leq 0.5$</td> <td>4</td> </tr> <tr> <td>$0.5 < D$</td> <td>NONE</td> </tr> </tbody> </table> <p>NOTE : DIAMETER $D = (a+b)/2$</p> 	AVERAGE DIAMETER (mm): D	NUMBER OF PIECES PERMITTED	$D \leq 0.15$	IGNORE	$0.15 < D \leq 0.5$	4	$0.5 < D$	NONE				
AVERAGE DIAMETER (mm): D	NUMBER OF PIECES PERMITTED													
$D \leq 0.15$	IGNORE													
$0.15 < D \leq 0.5$	4													
$0.5 < D$	NONE													

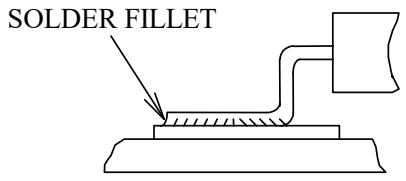
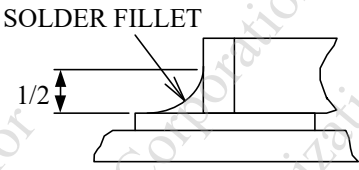
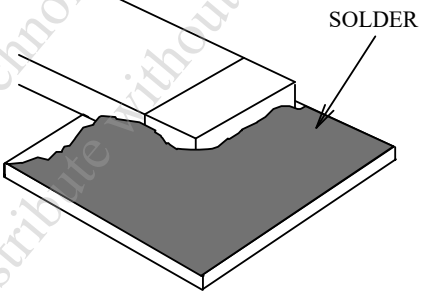
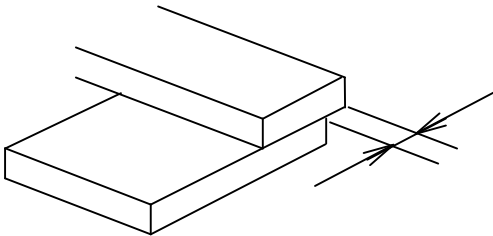
NO.	ITEM	CRITERIA		
			AVERAGE DIAMETER (mm) : D	NUMBER OF PIECES PERMITTED
7	BUBBLES OF POLARIZER /DIRT/CF FAIL /SURFACE STAINS	BUBBLE ON THE POLARIZER	$D \leq 0.25$	IGNORE
			$0.25 < D \leq 0.5$	$N \leq 5$
			$0.5 < D$	NONE
		SURFACE STAINS / DIRT / DENT	$D < 0.25$	IGNORE
			$0.25 < D \leq 0.4$	$N \leq 3$
			$D > 0.4$	NONE
		CF FAIL / SPOT	$D < 0.1$	IGNORE
			$0.1 < D \leq 0.3$	$N \leq 3$
			$D > 0.3$	NONE
		<p>NOTE : (1)POLARIZER BUBBLE IS DEFINED AS THE BUBBLE APPEARS ON ACTIVE DISPLAY AREA. THE DEFECT OF POLARIZER BUBBLE SHALL BE IGNORED IF THE POLARIZER BUBBLE APPEARS ON THE OUTSIDE OF ACTIVE DISPLAY AREA.</p> <p>(2)THE EXTRANEIOUS SUBSTANCE IS DEFINED AS IT CAN BE OBSERVED WHEN THE MODULE IS POWER ON.</p> <p>(3)THE DEFINITION OF AVERAGE DIAMETER, D IS DEFINED AS FOLLOWING.</p> <p>AVERAGE DIAMETER (D)=(a+b)/2</p> 		
8	LINE DEFECT ON DISPLAY	OBVIOUS VERTICAL OR HORIZONTAL LINE DEFECT IS NOT ALLOWED		
9	MURA ON DISPLAY	IT'S OK IF MURA IS SLIGHT VISIBLE THROUGH 5% ND FILTER		
10	UNEVEN COLOR SPREAD, COLORATION	1. TO BE DETERMINED BASED UPON THE STANDARD SAMPLE.		
11	BEZEL APPEARANCE	<p>1. BEZEL MAY NOT HAVE RUST, BE DEFORMED OR HAVE FINGER PRINTS STAINS OF OTHER CONTAMINATION.</p> <p>2. BEZEL MUST COMPLY WITH JOB SPECIFICATIONS.</p>		
12	PCB	<p>1. THERE MAY NOT BE MORE THAN 2mm OF SEALANT OUTSIDE THE SEAL AREA ON THE PCB, AND THERE SHOULD BE NO MORE THAN THREE PLACES.</p> <p>2. NO OXIDATION OR CONTAMINATION PCB TERMINALS.</p> <p>3. PARTS ON PCB MUST BE THE SAME AS ON THE PRODUCTION CHARACTERISTIC CHART. THERE SHOULD BE NO WRONG PARTS, MISSING PARTS OR EXCESS PARTS.</p> <p>4. THE JUMPER ON THE PCB SHOULD CONFORM TO THE PRODUCT CHARACTERISTIC CHART.</p> <p>5. IF SOLDER GETS ON BEZEL TAB PADS, LED PAD, ZEBRA PAD OR SCREW HOLD PAD; MAKE SURE IT IS SMOOTHED DOWN.</p>		

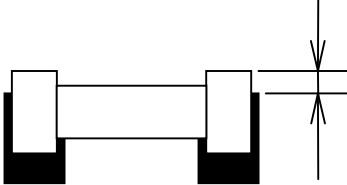
NO.	ITEM	CRITERIA
13	SOLDERING	<p>1. NO SOLDERING FOUND ON THE SPECIFIED PLACE</p> <p>2. INSUFFICIENT SOLDER</p> <p>(a) LSI, IC A POOR WETTING OF SOLDER IS BETWEEN LOWER BEND OR "HEEL" OF LEAD AND PAD</p>  <p>(b) CHIP COMPONENT · SOLDER IS LESS THAN 50% OF SIDES AND FRONT FACE WETTING</p>  <p>· SOLDER WETS 3 SIDES OF TERMINAL, BUT LESS THAN 25% OF SIDES AND FRONT SURFACE AREA ARE COVERED</p>  <p>3. PARTS ALIGNMENT</p> <p>(a) LSI, IC LEAD WIDTH IS MORE THAN 50% BEYOND PAD OUTLINE</p> 

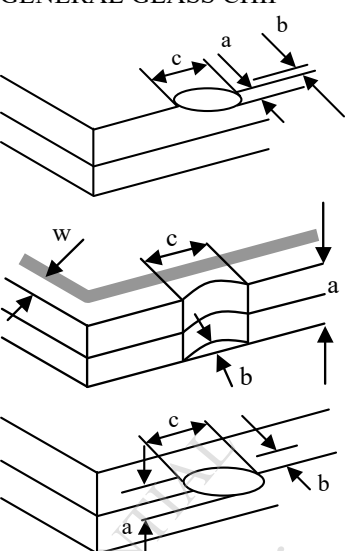
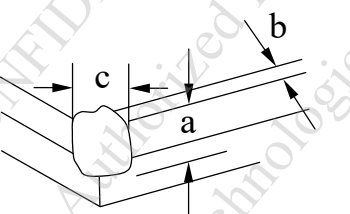
NO.	ITEM	CRITERIA
13	SOLDERING	<p>(b)CHIP COMPONENT COMPONENT IS OFF CENTER, AND MORE THAN 50% OF THE LEADS IS OFF THE PAD OUTLINE</p>  <p>4. NO UNMELTED SOLDER PASTE MAY BE PRESENT ON THE PCB. 5. NO COLD SOLDER JOINTS, MISSING SOLDER CONNECTIONS, OXIDATION OR ICICLE. 6. NO RESIDUE OR SOLDER BALLS ON PCB. 7. NO SHORT CIRCUITS IN COMPONENTS ON PCB.</p>
14	BACKLIGHT	<p>1. NO LIGHT 2. FLICKERING AND OTHER ABNORMAL ILLUMINATION 3. SPOTS OR SCRATCHES THAT APPEAR WHEN LIT MUST BE JUDGED USING LCD SPOT, LINES AND CONTAMINATION STANDARDS. 4. BACKLIGHT DOESN'T LIGHT OR COLOR IS WRONG.</p>
15	GENERAL APPEARANCE	<p>1. NO OXIDATION, CONTAMINATION, CURVES OR, BENDS ON INTERFACE PIN (OLB) OF TCP. 2. NO CRACKS ON INTERFACE PIN (OLB) OF TCP. 3. NO CONTAMINATION, SOLDER RESIDUE OR SOLDER BALLS ON PRODUCT. 4. THE IC ON THE TCP MAY NOT BE DAMAGED, CIRCUITS. 5. THE UPPERMOST EDGE OF THE PROTECTIVE STRIP ON THE INTERFACE PIN MUST BE PRESENT OR LOOK AS IF IT CAUSE THE INTERFACE PIN TO SEVER. 6. THE RESIDUAL ROSIN OR TIN OIL OF SOLDERING (COMPONENT OR CHIP COMPONENT) IS NOT BURNED INTO BROWN OR BLACK COLOR. 7. SEALANT ON TOP OF THE ITO CIRCUIT HAS NOT HARDENED. 8. PIN TYPE MUST MATCH TYPE IN SPECIFICATION SHEET. 9. LCD PIN LOOSE OR MISSING PINS. 10. PRODUCT PACKAGING MUST THE SAME AS SPECIFIED ON PACKAGING SPECIFICATION SHEET. 11. PRODUCT DIMENSION AND STRUCTURE MUST CONFORM TO PRODUCT SPECIFICATION SHEET. 12. THE APPEARANCE OF HEAT SEAL SHOULD NOT ADMIT ANY DIRT AND BREAK.</p>

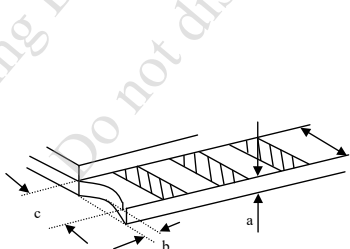
NO.	ITEM	CRITERIA										
16	CRACKED GLASS	THE LCD WITH EXTENSIVE CRACK IS NOT ACCEPTABLE										
		<p>GENERAL GLASS CHIP :</p> 	<table border="1" data-bbox="938 380 1455 459"> <thead> <tr> <th>a</th> <th>b</th> <th>c</th> </tr> </thead> <tbody> <tr> <td>$\leq t/2$</td> <td>< VIEWING AREA</td> <td>$\leq 1/8X$</td> </tr> <tr> <td>$t/2 >, \leq 2t$</td> <td>$\leq W/2$</td> <td>$\leq 1/8X$</td> </tr> </tbody> </table> <p>*W=DISTANCE BETWEEN SEALANT AREA AND LCD PANEL EDGE X = LCD SIDE LENGTH t = GLASS THICKNESS</p>	a	b	c	$\leq t/2$	< VIEWING AREA	$\leq 1/8X$	$t/2 >, \leq 2t$	$\leq W/2$	$\leq 1/8X$
		a	b	c								
		$\leq t/2$	< VIEWING AREA	$\leq 1/8X$								
$t/2 >, \leq 2t$	$\leq W/2$	$\leq 1/8X$										
<p>CORNER PART :</p> 	<table border="1" data-bbox="938 974 1455 1052"> <thead> <tr> <th>a</th> <th>b</th> <th>c</th> </tr> </thead> <tbody> <tr> <td>$\leq t/2$</td> <td>< VIEWING AREA</td> <td>$\leq 1/8X$</td> </tr> <tr> <td>$> t/2, \leq 2t$</td> <td>$\leq W/2$</td> <td>$\leq 1/8X$</td> </tr> </tbody> </table> <p>*W=DISTANCE BETWEEN SEALANT AREA AND LCD PANEL EDGE X = LCD SIDE LENGTH t = GLASS THICKNESS</p>	a	b	c	$\leq t/2$	< VIEWING AREA	$\leq 1/8X$	$> t/2, \leq 2t$	$\leq W/2$	$\leq 1/8X$		
a	b	c										
$\leq t/2$	< VIEWING AREA	$\leq 1/8X$										
$> t/2, \leq 2t$	$\leq W/2$	$\leq 1/8X$										
<p>CHIP ON ELECTRODE PAD</p> 	<table border="1" data-bbox="938 1243 1455 1299"> <thead> <tr> <th>a</th> <th>b</th> <th>c</th> </tr> </thead> <tbody> <tr> <td>$\leq t$</td> <td>$\leq 0.5\text{mm}$</td> <td>$\leq 1/8X$</td> </tr> </tbody> </table> <p>* X=LCD SIDE WIDTH t=GLASS THICKNESS</p>	a	b	c	$\leq t$	$\leq 0.5\text{mm}$	$\leq 1/8X$					
a	b	c										
$\leq t$	$\leq 0.5\text{mm}$	$\leq 1/8X$										
	<table border="1" data-bbox="938 1400 1455 1456"> <thead> <tr> <th>a</th> <th>b</th> <th>c</th> </tr> </thead> <tbody> <tr> <td>$\leq t$</td> <td>$\leq 1/8X$</td> <td>$\leq L$</td> </tr> </tbody> </table> <p>*X=LCD SIDE WIDTH t = GLASS THICKNESS L=ELECTRODE PAD LENGTH ①IF GLASS CHIPPING THE ITO TERMINAL, OVER 2/3 OF THE ITO MUST REMAIN AND BE, INSPECTED ACCORDING TO ELECTRODE TERMINAL SPECIFICATIONS ②IF THE PRODUCT WILL BE HEAT SEALED BY THE CUSTOMER, THE ALIGNMENT MARK MUST NOT BE DAMAGED</p>	a	b	c	$\leq t$	$\leq 1/8X$	$\leq L$					
a	b	c										
$\leq t$	$\leq 1/8X$	$\leq L$										

13. RELIABILITY TEST

13.1 STANDARD SPECIFICATIONS FOR RELIABILITY OF LCD MODULE

NO.	ITEM	DESCRIPTION
1	HIGH TEMPERATURE TEST (OPERATION)	THE SAMPLE SHOULD BE ALLOWED TO STAND AT +70°C FOR 240 HRS
2	LOW TEMPERATURE TEST (OPERATION)	THE SAMPLE SHOULD BE ALLOWED TO STAND AT -20°C FOR 240 HRS
3	HIGH TEMPERATURE TEST (STORAGE)	THE SAMPLE SHOULD BE ALLOWED TO STAND AT +80°C FOR 240 HRS
4	LOW TEMPERATURE TEST (STORAGE)	THE SAMPLE SHOULD BE ALLOWED TO STAND AT -30°C FOR 240 HRS
5	HIGH TEMPERATURE / HUMIDITY TEST (OPERATION)	THE SAMPLE SHOULD BE ALLOWED TO STAND AT 60°C, 90% RH 240 HRS
6	THERMAL SHOCK TEST (NOT OPERATED)	<p>THE SAMPLE SHOULD BE ALLOWED TO STAND THE FOLLOWING 10 CYCLES OF OPERATION :</p> <p>The diagram shows a temperature cycle starting at -30°C. It ramps up to +80°C over a 30-minute period. It then holds at +80°C for 3 minutes. It then ramps down to -30°C over a 30-minute period. Finally, it holds at -30°C for 3 minutes. This entire sequence is labeled as '1 CYCLE'.</p>
7	VIBRATION (NOT OPERATED)	11.76 m/s ² (1.2G), 10~100 Hz XYZ DIRECTIONS, 1 HR EACH
8	SHOCK (NOT OPERATED)	490.0 m/s ² (50G), 10 ms XYZ DIRECTIONS, 1 TIME EACH
9	ESD (ELECTROSTATIC DISCHARGE) (NOT OPERATED)	AIR DISCHARGE ± 8KV CONTACT DISCHARGE ± 4KV (ACCORDING TO IEC-61000-4-2)

NOTE (1) : THE TEST SAMPLES HAVE RECOVERY TIME FOR 2 HOURS AT ROOM TEMPERATURE BEFORE THE FUNCTION CHECK. IN THE STANDARD CONDITIONS, THERE IS NO DISPLAY FUNCTIONING ISSUE OCCURRED.

NOTE (2) : WHEN THE LCD MODULE IS OPERATED AT A HIGHER AMBIENT TEMPERATURE THAN 60°C, POWER SUPPLY CURRENT OF LED BACKLIGHT SHOULD BE ADJUSTED TO BE LESS THAN TBD%. IF THE MODULE IS OPERATED AT A HIGHER CURRENT THAN TBD%, THEN THERE IS A POSSIBILITY OF DISTORTION AND IRREGULARITY OF THE PICTURE DUE TO LIQUID CRYSTAL BEHAVIOR.

NOTE (3) : TESTING CONDITIONS AND INSPECTION CRITERIA

NO.	ITEM	TEST MODEL	INSPECTION CRITERIA
1	CURRENT CONSUMPTION	REFER TO SPECIFICATION	THE CURRENT CONSUMPTION SHOULD CONFORM TO THE PRODUCT SPECIFICATION.
2	CONTRAST	REFER TO SPECIFICATION	AFTER THE TESTS HAVE BEEN EXECUTED, THE CONTRAST MUST BE LARGER THAN HALF OF ITS INITIAL VALUE PRIOR TO THE TESTS.
3	APPEARANCE	VISUAL INSPECTION	DEFECT FREE

14. CAUTION

14.1 OPERATION

- 14.1.1 DO NOT CONNECT OR DISCONNECT MODULES TO OR FROM THE MAIN SYSTEM WHILE POWER IS BEING SUPPLIED .
- 14.1.2 USE THE MODULE WITHIN SPECIFIED TEMPERATURE ; LOWER TEMPERATURE CAUSES THE RETARDATION OF BLINKING SPEED OF THE DISPLAY ; HIGHER TEMPERATURE MAKES OVERALL DISPLAY DISCOLOR . WHEN THE TEMPERATURE RETURNS TO NORMALITY, THE DISPLAY WILL OPERATE NORMALLY.
- 14.1.3 ADJUST THE LC DRIVING VOLTAGE TO OBTAIN THE OPTIMUM CONTRAST .
- 14.1.4 POWER ON SEQUENCE INPUT SIGNALS SHOULD NOT BE SUPPLIED TO LCD MODULE BEFORE POWER SUPPLY VOLTAGE IS APPLIED AND REACHES THE SPECIFIED VALUE.
IF ABOVE SEQUENCE IS NOT FOLLOWED , CMOS LSIS OF LCD MODULES MAY BE DAMAGED DUE TO LATCH - UP PROBLEM.
- 14.1.5 NOT ALLOWED TO INFLICT ANY EXTERNAL STRESS AND TO CAUSE ANY MECHANICAL INTERFERENCE ON THE BENDING AREA OF FPC DURING THE TAIL BENDING BACKWARDS!
DO NOT STRESS FPC AND IC ON THE MODULE!

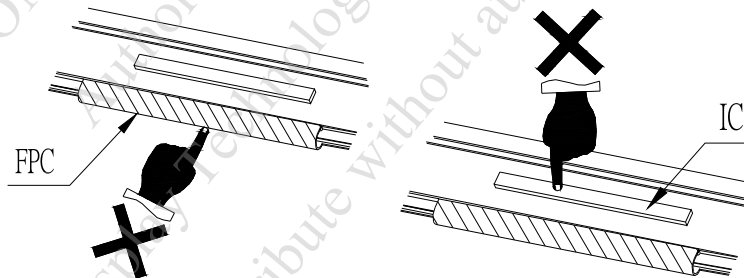

14.2 STORAGE

- 14.2.1 STORE THE MODULE IN A DARK ROOM OR KEEP IN ORIGINAL PACKAGE WHERE MUST KEEP AT $25\pm 10^{\circ}\text{C}$ AND 65%RH OR LESS.
- 14.2.2 DO NOT STORE THE MODULE IN SURROUNDINGS CONTAINING ORGANIC SOLVENT OR CORROSIVE GAS.
- 14.2.3 STORE THE MODULE IN AN ANTI-ELECTROSTATIC CONTAINER OR BAG.

14.3 NOTICE

- 14.3.1 USE A GROUNDED SOLDERING IRON WHEN SOLDERING CONNECTOR I/O TERMINALS . FOR SOLDERING OR REPAIRING, TAKE PRECAUTION AGAINST THE TEMPERATURE OF THE SOLDERING IRON AND THE SOLDERING TIME TO PREVENT PEELING OFF THE THROUGH-HOLE-PAD.
- 14.3.2 DO NOT DISASSEMBLE . EDT SHALL NOT BE HELD RESPONSIBLE IF THE MODULE IS DISASSEMBLED AND UPON THE REASSEMBLY THE MODULE FAILED.
- 14.3.3 DO NOT CHARGE STATIC ELECTRICITY, AS THE CIRCUIT OF THIS MODULE CONTAINS CMOS LSIS. A WORKMAN'S BODY SHOULD ALWAYS BE STATIC-PROTECTED BY USE OF AN ESD STRAP. WORKING CLOTHES FOR SUCH PERSONNEL SHOULD BE OF STATIC-PROTECTED MATERIAL.
- 14.3.4 ALWAYS GROUND THE ELECTRICALLY-POWERED DRIVER BEFORE USING IT TO INSTALL THE LCD MODULE. WHILE CLEANING THE WORK STATION BY VACUUM CLEANER, DO NOT BRING THE SUCKING MOUTH NEAR THE MODULE ; STATIC ELECTRICITY OF THE ELECTRICALLY-POWERED DRIVER OR THE VACUUM CLEANER MAY DESTROY THE MODULE.
- 14.3.5 DON'T GIVE EXTERNAL SHOCK.
- 14.3.6 DON'T APPLY EXCESSIVE FORCE ON THE SURFACE.
- 14.3.7 LIQUID IN LCD IS HAZARDOUS SUBSTANCE. MUST NOT LICK AND SWALLOW.
WHEN THE LIQUID IS ATTACH TO YOUR, SKIN, CLOTH ETC. WASH IT OUT THOROUGHLY AND IMMEDIATELY.
- 14.3.8 DON'T OPERATE IT ABOVE THE ABSOLUTE MAXIMUM RATING.
- 14.3.9 STORAGE IN A CLEAN ENVIRONMENT, FREE FROM DUST, ACTIVE GAS, AND SOLVENT.
- 14.3.10 STORE WITHOUT ANY PHYSICAL LOAD.
- 14.3.11 REWIRING: NO MORE THAN 3 TIMES.