

EXAMINED BY :	EMERGING DISPLAY TECHNOLOGIES CORPORATION	FILE NO . CAS-0009748
Lucica Lu		ISSUE : NOV.14, 2024
APPROVED BY:		TOTAL PAGE : 31
Vincent Wn		VERSION : 2

CUSTOMER ACCEPTANCE SPECIFICATIONS

MODEL NO. :

ET0350G9DHA

(RoHS)

FOR MESSRS : \_\_\_\_\_

CUSTOMER'S APPROVAL

DATE :

\_\_\_\_\_

BY :

\_\_\_\_\_

RECORDS OF REVISION	DOC . FIRST ISSUE	NOV.05, 2024
---------------------	-------------------	--------------

DATE	REVISED PAGE NO.	SUMMARY
NOV.14, 2024	15	<p>11.1 POWER SUPPLY FOR LCM</p>
<p>CONFIDENTIAL Authorized for Emerging Display Technologies Corporation Only Do not distribute without authorization.</p>		

TABLE OF CONTENTS

NO.	ITEM	PAGE
1.	GENERAL SPECIFICATIONS -----	1
2.	MECHANICAL SPECIFICATIONS -----	1
3.	ABSOLUTE MAXIMUM RATINGS -----	2
4.	ELECTRICAL CHARACTERISTICS -----	3
5.	TIMING CHARACTERISTICS -----	4 ~ 7
6.	OPTICAL CHARACTERISTICS -----	8 , 9
7.	OUTLINE DIMENSIONS -----	10
8.	BLOCK DIMENSION -----	11
9.	DETAIL DRAWING OF DOT MATRIX -----	12
10.	INTERFACE SIGNALS -----	13 , 14
11.	POWER SUPPLY -----	15
12.	CAPACITIVE TOUCH PANEL SPECIFICATION -----	16 ~ 21
13.	INSPECTION CRITERIA -----	22 ~ 28
14.	RELIABILITY TEST -----	29
15.	CAUTION -----	30 , 31

CONFIDENTIAL  
Authorized for Emerging Display Technologies Corporation Only.  
Do not distribute without authorization.

## 1. GENERAL SPECIFICATIONS

### 1.1 DATA SHEET FOR CONTROLLER/DRIVER PLEASE REFER TO :

SITRONIX ST7272A-G4

### 1.2 MATERIAL SAFETY DESCRIPTION

ASSEMBLIES SHALL COMPLY WITH EUROPEAN ROHS REQUIREMENTS, INCLUDING PROHIBITED MATERIALS/COMPONENTS CONTAINING LEAD, MERCURY, CADMIUM, HEXAVALENT CHROMIUM, POLYBROMINATED BIPHENYLS (PBB) AND POLYBROMINATED DIPHENYL ETHERS (PBDE), BIS(2-ETHYLHEXYL) PHTHALATE (DEHP), BUTYL BENZYL PHTHALATE (BBP), DIBUTYL PHTHALATE (DBP), DIISOBUTYL PHTHALATE (DIBP).

## 2. MECHANICAL SPECIFICATIONS

( 1 ) DISPLAY SIZE	-----	3.5 inch
( 2 ) NUMBER OF DOTS	-----	320W * (RGB) * 240H DOTS
( 3 ) MODULE SIZE	-----	76.8W * 63.8H *8.6D(MAX.) mm (NOT INCLUDED FPC)
( 4 ) VIEWING AREA	-----	71.6W * 54H mm
( 5 ) ACTIVE AREA	-----	70.08W * 52.56H mm (LCD) 70.8W * 53.26H mm (T/P)
( 6 ) DOT SIZE	-----	0.073W * 0.219H mm
( 7 ) PIXEL SIZE	-----	0.219W * 0.219H mm
( 8 ) LCD TYPE	-----	TFT , TRANSMISSIVE, NORMALLY BLACK
( 9 ) COLOR	-----	262K
( 10 ) VIEWING DIRECTION	-----	SUPER WIDE VIEW
( 11 ) BACKLIGHT	-----	LED , COLOR : WHITE
( 12 ) INTERFACE MODE	-----	RGB 18BIT PARALLEL (DE/SYNC MODE)
( 13 ) WEIGHT	-----	TBD

### 3. ABSOLUTE MAXIMUM RATINGS

#### 3.1 ELECTRICAL ABSOLUTE MAXIMUM RATINGS

ITEM	SYMBOL	MIN.	MAX.	UNIT	REMARK
POWER SUPPLY VOLTAGE	VDD-VSS	-0.3	4	V	—
STATIC ELECTRICITY	—	—	—	V	NOTE (1)
POWER DISSIPATION FOR LED BACKLIGHT	PD	—	465	mW	—
FORWARD CURRENT FOR LED BACKLIGHT	ILED	—	30	mA	—
	VR	—	30	V	—

NOTE (1) : LCM SHOULD BE GROUND DURING LCM HANDLING.

#### 3.2 ENVIRONMENTAL ABSOLUTE MAXIMUM RATINGS

ITEM	OPERATING		STORAGE		REMARK
	MIN.	MAX.	MIN.	MAX.	
AMBIENT TEMPERATURE	-20°C	70°C	-30°C	80°C	NOTE (1), (2), (3)
HUMIDITY	NOTE (3)		NOTE (3)		WITHOUT CONDENSATION
CORROSIVE GAS	NOT ACCEPTABLE		NOT ACCEPTABLE		

NOTE (1) : THE ABSOLUTE MAXIMUM RATINGS OF THIS PRODUCT SHOULD NOT BE EXCEEDED AT ANY TIME. IF THESE RATINGS ARE EXCEEDED, THE PRODUCT'S PERFORMANCE IS NOT GUARANTEED AND THE PRODUCT MAY EXPERIENCE PERMANENT DAMAGE.

NOTE (2) : BACKGROUND COLOR CHANGES SLIGHTLY DEPENDING ON AMBIENT TEMPERATURE THIS PHENOMENON IS REVERSIBLE.

NOTE (3) : Ta ≤ 60°C : 90%RH MAX.

Ta > 60°C : ABSOLUTE HUMIDITY MUST BE LOWER THAN THE HUMIDITY OF 90%RH AT 60°C.

4. ELECTRICAL CHARACTERISTICS

Ta = 25 °C

ITEM	SYMBOL	CONDITION	MIN.	TYP.	MAX.	UNIT	REMARK
POWER SUPPLY VOLTAGE	VDD-VSS	—	2.5	3.3	3.6	V	
POWER SUPPLY VOLTAGE FOR LED DRIVER	VCC-VSS	—	2.7	3.3	3.6	V	
LOGIC HIGH INPUT VOLTAGE	VIH	H LEVEL	0.7*VDD	—	—	V	NOTE ( 1 )
LOGIC LOW INPUT VOLTAGE	VIL	L LEVEL	0	—	0.3*VDD	V	
POWER SUPPLY CURRENT	IDD	VDD-VSS=3.3V	—	(20)	(30)	mA	NOTE ( 2 )
POWER SUPPLY CURRENT FOR LED DRIVER	ICC	VCC-VSS=3.3V LED B/L=ON	—	(390)	(510)	mA	
LED LIFE TIME	—	—	30K	40K	—	HRS	NOTE ( 5 ) NOTE ( 6 )

NOTE ( 1 ) : APPLIED TO TERMINALS /RESET, B5~B0, G5~G0, R5~R0, DCLK, HSYNC, VSYNC, ENB.

NOTE ( 2 ) : THE DISPLAY PATTERN IS ALL “WHITE”.

NOTE ( 3 ) : INTERNAL CIRCUIT DIAGRAM OF BACKLIGHT

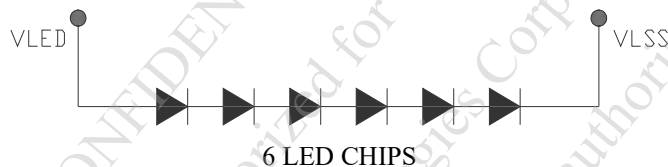

6 LED CHIPS

NOTE ( 4 ) : AMBIENT TEMP .VS. ALLOWABLE FORWARD CURRENT.(PER LED)

Forward current derating curve VS.Ambient temperature

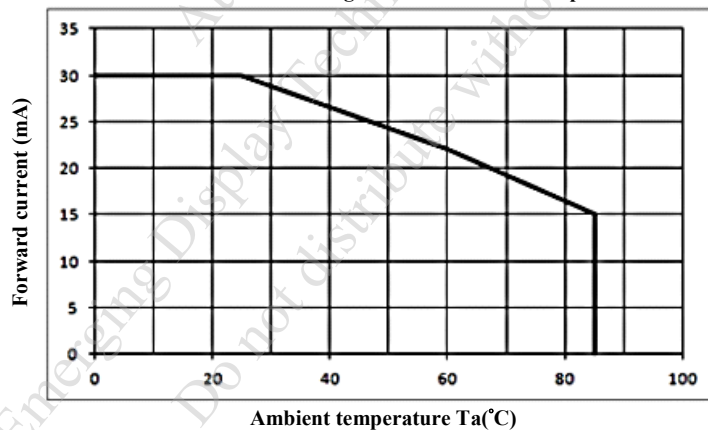

NOTE ( 5 ) : CONDITIONS; TA=25 °C, CONTINUOUS LIGHTING.

NOTE ( 6 ) : DEFINITIONS OF LIFE TIME :

LCM LUMINANCE BECOMES HALF OF THE INITIAL VALUE.

5. TIMING CHARACTERISTICS

5.1 PIXEL TIMING

ITEM	SYMBOL	MIN.	TYP.	MAX.	UNIT
CLK PULSE DUTY	Tclk	40	50	60	%
HSYNC WIDTH	Thw	2	—	—	DCLK
HSYNC PERIOD	Th	55	60	65	us
VSYNC SETUP TIME	Tvst	12	—	—	ns
VSYNC HOLD TIME	Tvhd	12	—	—	ns
HSYNC SETUP TIME	Thst	12	—	—	ns
HSYNC HOLD TIME	Thhd	12	—	—	ns
DATA SETUP TIME	Tdsu	12	—	—	ns
DATA HOLD TIME	Tdhd	12	—	—	ns
DE SETUP TIME	Tdest	12	—	—	ns
DE HOLD TIME	Tdehd	12	—	—	ns

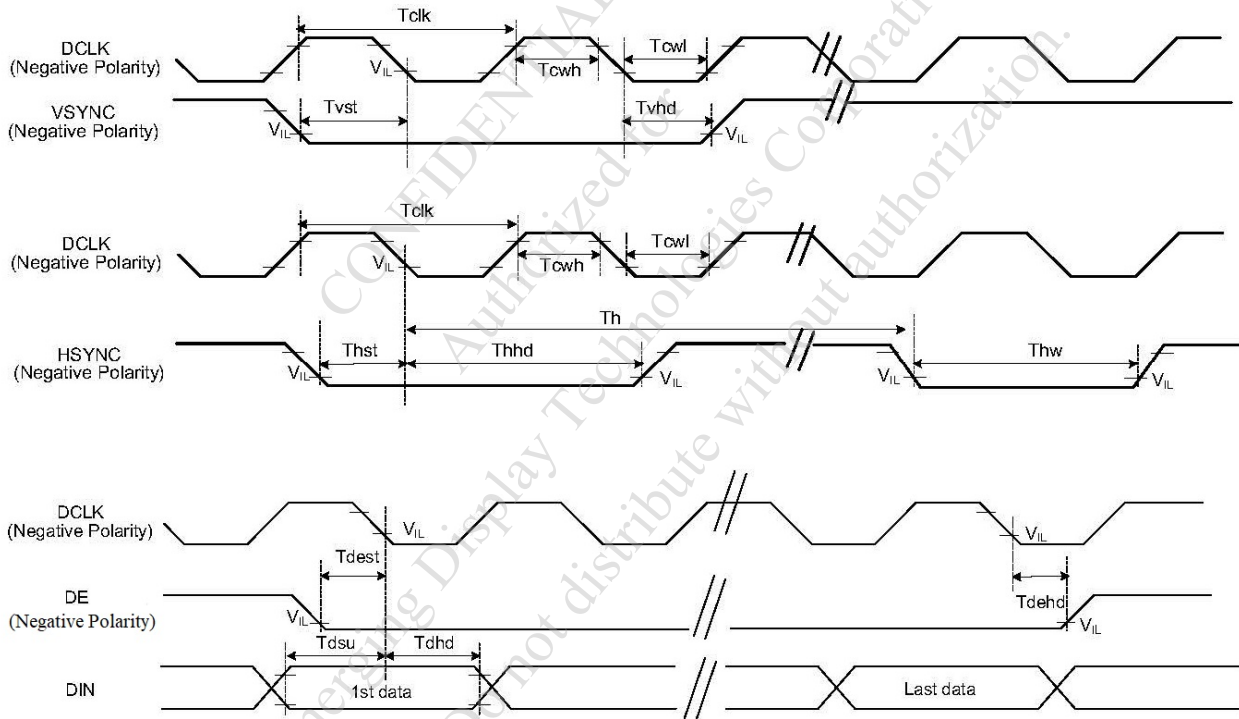

5.2 PARALLEL RGB INPUT TIMING TABLE

ITEM	SYMBOL	MIN.	TYP.	MAX.	UNIT	NOTE	
DCLK FREQUENCY	Fclk	5	6	8	MHz		
DCLK PERIOD	Tclk	125	167	200	ns		
HSYNC	PERIOD TIME	Th	325	371	438	DCLK	
	DISPLAY PERIOD	Thdisp	—	320	—	DCLK	
	BACK PORCH	Thbp	3	43	43	DCLK	SYNC MODE BACK PORCH CONTROL BY H_BLANKING[7:0] SETTING Thbp=H_BLANKING[7:0]
	FRONT PORCH	Thfp	2	8	75	DCLK	
	PULSE WIDTH	Thw	2	4	43	DCLK	
VSYNC	PERIOD TIME	Tv	244	260	289	HSYNC	
	DISPLAY PERIOD	Tvdisp	—	240	—	HSYNC	
	BACK PORCH	Tvbp	2	12	12	HSYNC	SYNC MODE BACK PORCH CONTROL BY V_BLANKING[7:0] SETTING Tvbp=V_BLANKING[7:0]
	FRONT PORCH	Tvfp	2	8	37	HSYNC	
	PULSE WIDTH	Tvw	2	4	12	HSYNC	

NOTE: IT IS NECESSARY TO KEEP Tvbp=12 AND Thbp=43 IN SYNC MODE. DE MODE IS UNNECESSARY TO KEEP IT.

5.3 PARALLEL RGB INTERFACE (SYNC MODE)

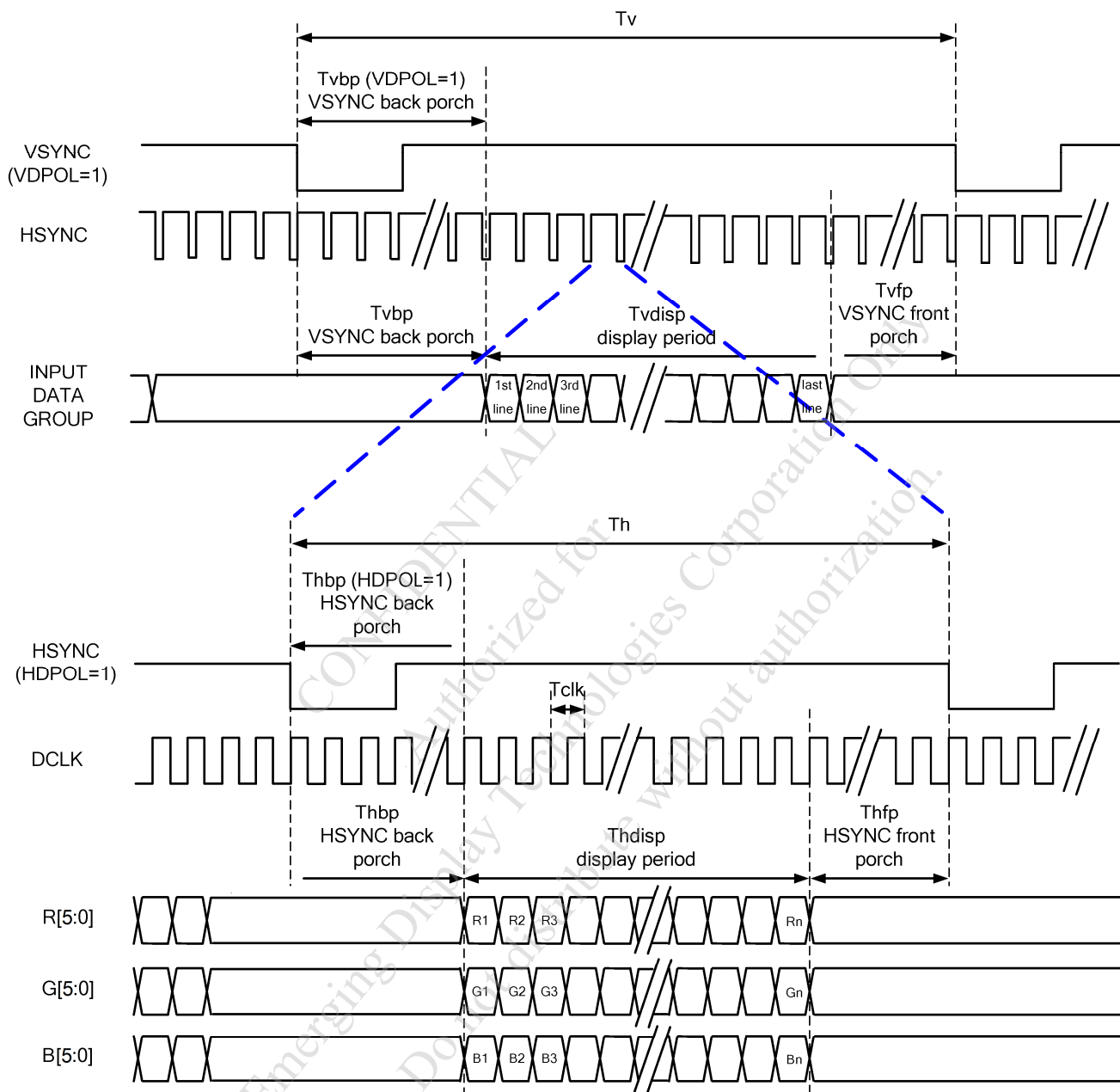

5.4 PARALLEL RGB INTERFACE (DE MODE)

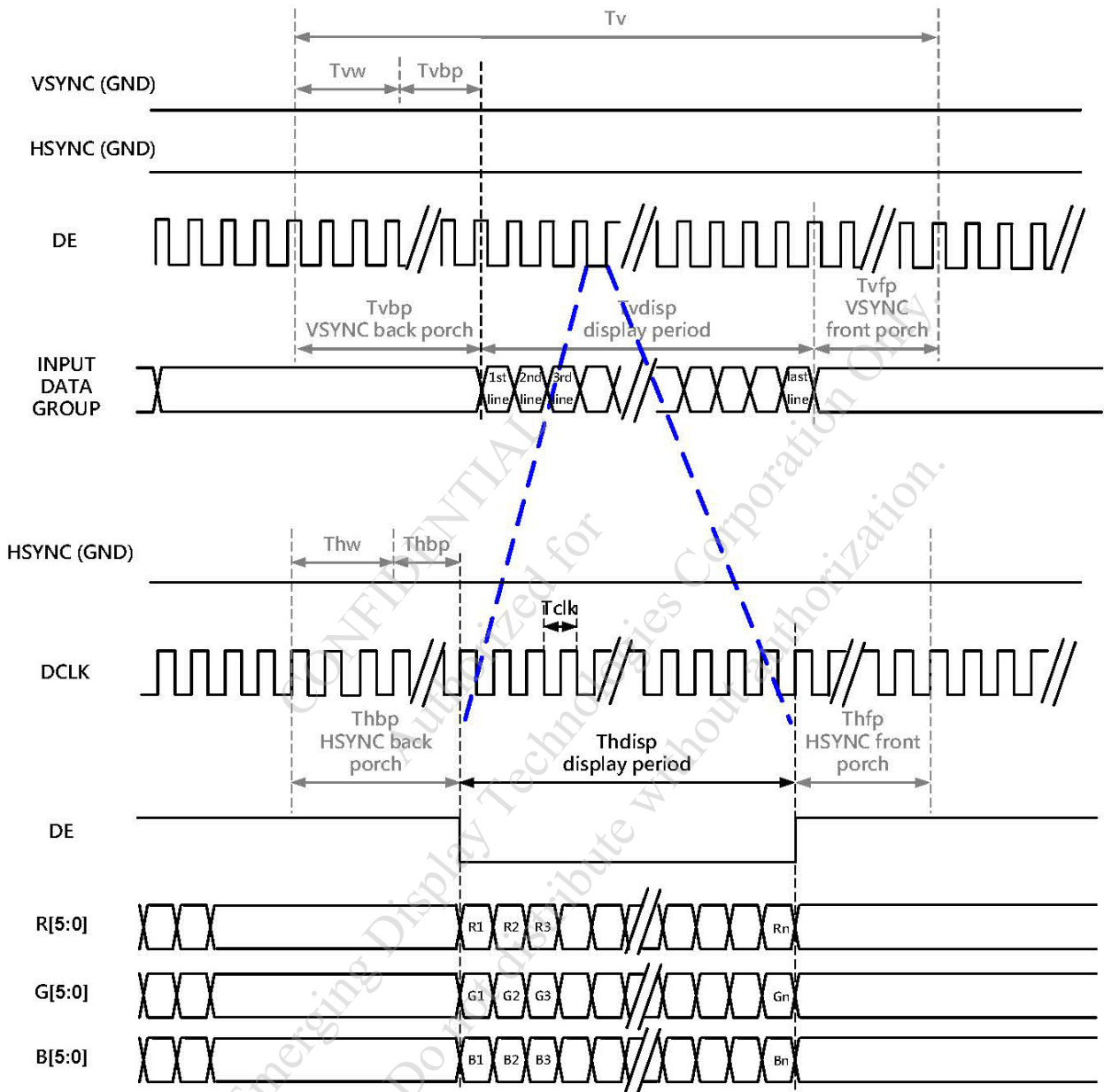

6. OPTICAL CHARACTERISTICS

6.1 OPTICAL CHARACTERISTICS(NOTE 1)

Ta=25±2°C

ITEM	SYMBOL	CONDITION	MIN.	TYP.	MAX.	UNIT	REMARK	
VIEWING ANGLE	$\theta_{y+}$	CR≥10	$\theta_x=0^\circ$	70	80	—	deg	NOTE (2)
	$\theta_{y-}$			70	80	—	deg	
	$\theta_{x+}$	$\theta_y=0^\circ$	70	80	—	deg	NOTE (3)	
	$\theta_{x-}$		70	80	—	deg		
CONTRAST RATIO (CENTER)	CR	$\theta_x=0^\circ, \theta_y=0^\circ$	600	800	—	—	NOTE (3)	
RESPONSE TIME	T <sub>R</sub> (rise)		—	10	20	msec	NOTE (4)	
	T <sub>F</sub> (fall)		—	15	30	msec	NOTE (4)	
COLOR CHROMATICITY (CENTER)	WHITE	W <sub>x</sub>	$\theta_x=0^\circ, \theta_y=0^\circ$ VDD-VSS=3.3V VCC-VSS=3.3V	0.25	0.30	0.35	—	NOTE (5)
		W <sub>y</sub>		0.26	0.31	0.36		
	RED	R <sub>x</sub>		0.57	0.62	0.67	—	
		R <sub>y</sub>		0.30	0.35	0.40		
	GREEN	G <sub>x</sub>		0.32	0.37	0.42	—	
		G <sub>y</sub>		0.54	0.59	0.64		
	BLUE	B <sub>x</sub>		0.09	0.14	0.19	—	
		B <sub>y</sub>		0.03	0.08	0.13		
THE BRIGHTNESS OF MODULE(CENTER)	B		360	400	—	cd/m <sup>2</sup>	NOTE (6)	
THE UNIFORMITY OF MODULE	—		70	—	—	%	NOTE (7)	

NOTE (1) : TEST EQUIPMENT SETUP :

AFTER STABILIZING AND LEAVING THE PANEL ALONE AT A GIVEN TEMPERATURE FOR 30 MINUTES. MEASUREMENT SHOULD BE EXECUTED IN A STABLE, WINDLESS, AND DARK ROOM.

THE MEASUREMENT CRITERIA AND CONDITION FOR EITHER BM-5A OR CA-210 OR EQUIVALENT LUMINANCE METER IS BASED ON THE EQUIPMENT'S MANUAL.

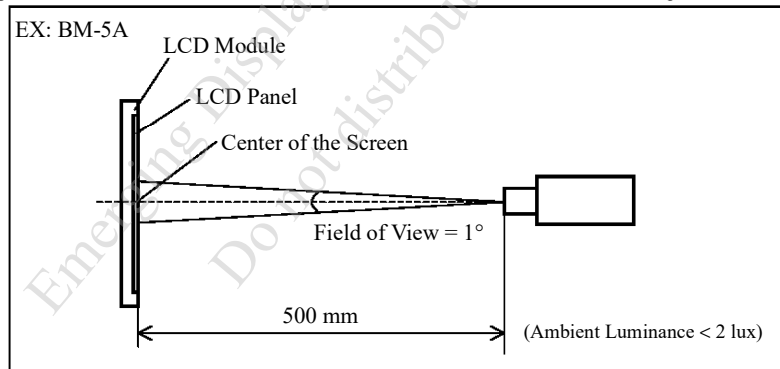

NOTE (2) : DEFINITION OF VIEWING ANGLE :

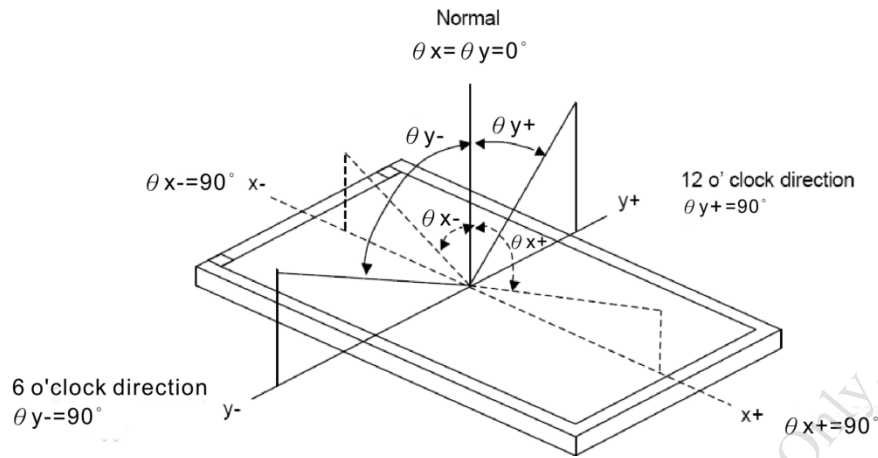

NOTE (3) : DEFINITION OF CONTRAST RATIO (CR) :

MEASURED AT THE CENTER POINT OF MODULE

$$\text{CONTRAST RATIO (CR)} = \frac{\text{BRIGHTNESS MEASURED WHEN LCD IS AT "WHITE STATE"}}{\text{BRIGHTNESS MEASURED WHEN LCD IS AT "BLACK STATE"}}$$

NOTE (4) : DEFINITION OF RESPONSE TIME : T<sub>R</sub> AND T<sub>F</sub>

THE FIGURE BELOW IS THE OUTPUT SIGNAL OF THE PHOTO DETECTOR.

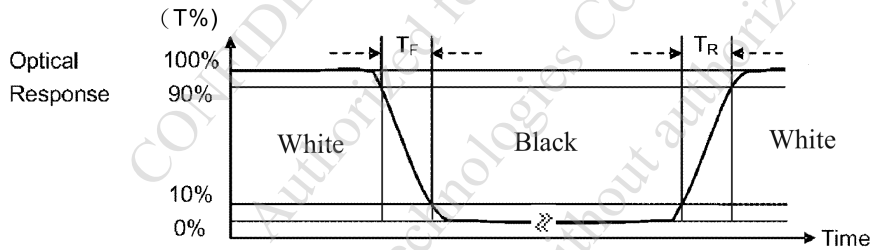

NOTE (5) : DEFINITION OF COLOR CHROMATICITY

(a) 100% RGB PIXEL DATA TRANSMISSION WHEN ALL THE INPUT TERMINALS OF MODULE ARE ELECTRICALLY POWERED ON.

(b) MEASURED AT THE CENTER POINT OF MODULE

NOTE (6) : MEASURED THE BRIGHTNESS OF WHITE STATE AT CENTER POINT.

NOTE (7) : (a) DEFINITION OF BRIGHTNESS UNIFORMITY

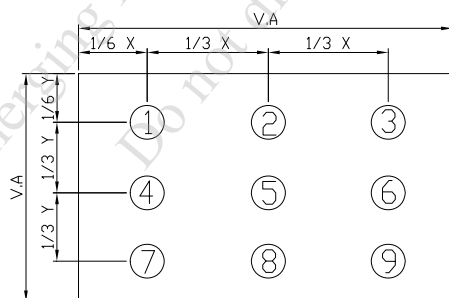

UNIT : mm

(b) THE BRIGHTNESS UNIFORMITY CALCULATING METHOD

$$\text{UNIFORMITY} : \frac{\text{MINIMUM BRIGHTNESS}}{\text{MAXIMUM BRIGHTNESS}} * 100\%$$

7. OUTLINE DIMENSIONS

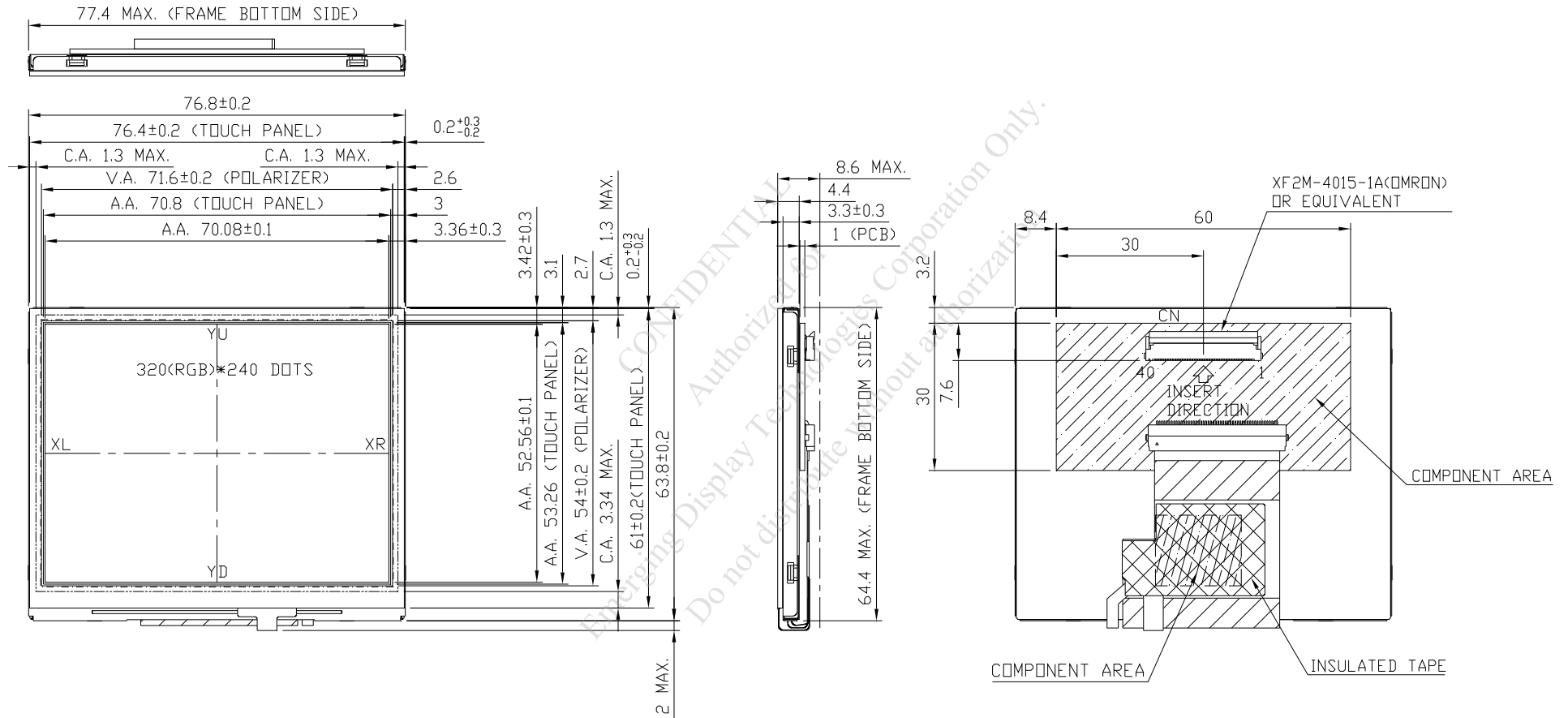

UNIT : mm  
SCALE : NTS

THIRD ANGLE PROJECTION  
NOT SPECIFIED TOLERANCE IS±0.5mm

8. BLOCK DIMENSION

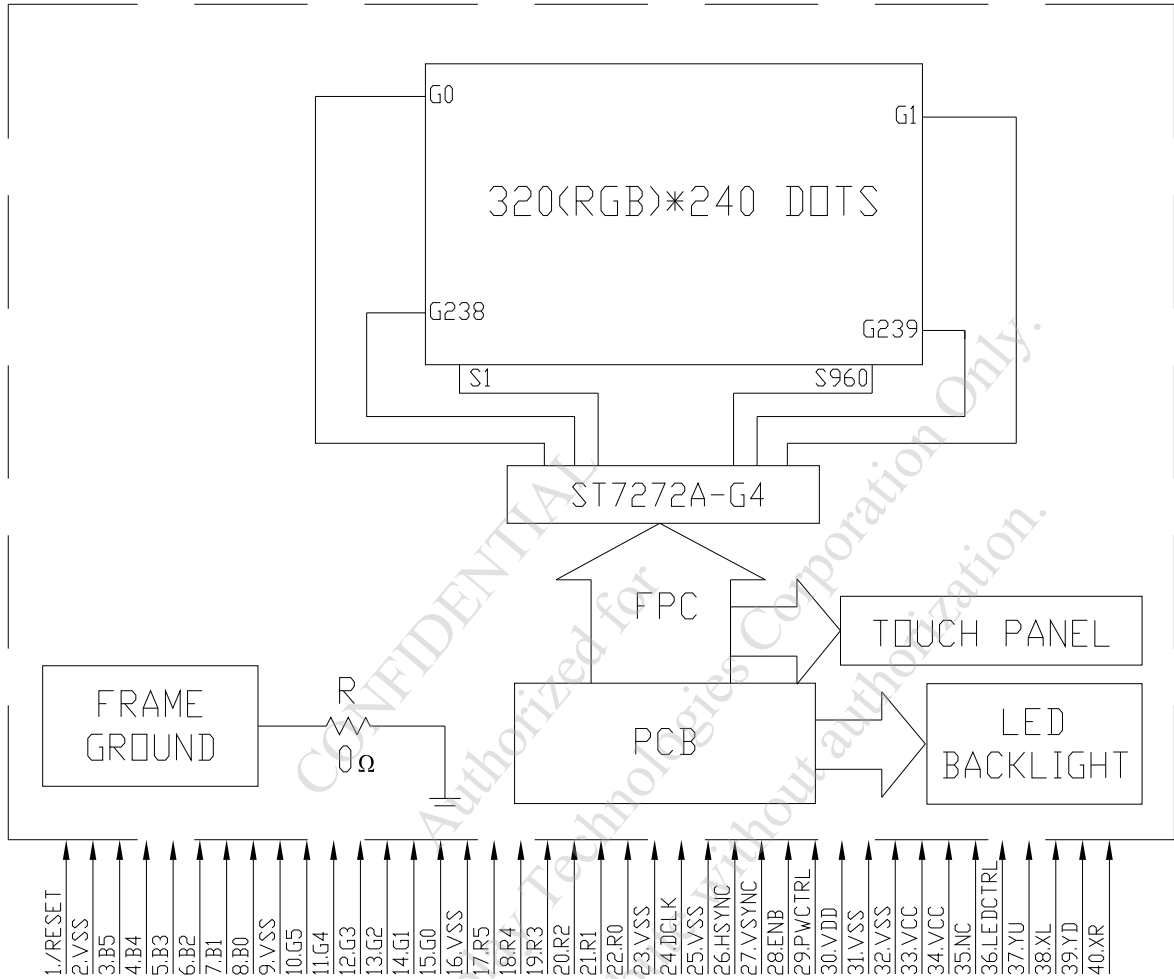

9. DETAIL DRAWING OF DOT MATRIX

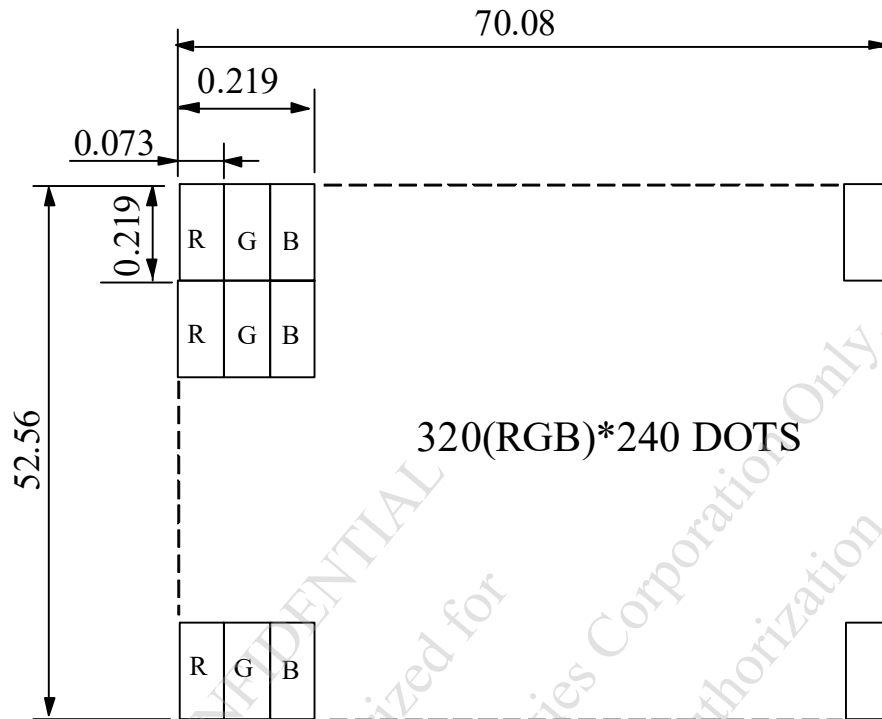

UNIT : mm  
SCALE : NTS  
NOT SPECIFIED TOLERANCE IS  $\pm 0.1$   
DOTS MATRIX TOLERANCE IS  $\pm 0.01$

CONFIDENTIAL  
Authorized for  
Emerging Display Technologies Corporation Only  
Do not distribute without authorization

10. INTERFACE SIGNALS

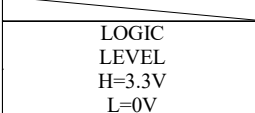
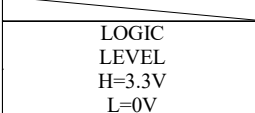
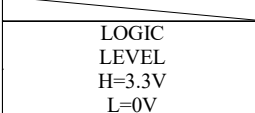
PIN NO.	SYMBOL	I/O/P	FUNCTION									
1	/RESET	I	HARDWARE RESET									
2	VSS	P	GROUND (VSS IS CONNECTED TO METAL HOUSING WITH CONDUCTIVE TAPE)									
3	B5	I	BLUE DATA BIT 5									
4	B4	I	BLUE DATA BIT 4									
5	B3	I	BLUE DATA BIT 3									
6	B2	I	BLUE DATA BIT 2									
7	B1	I	BLUE DATA BIT 1									
8	B0	I	BLUE DATA BIT 0									
9	VSS	P	GROUND (VSS IS CONNECTED TO METAL HOUSING WITH CONDUCTIVE TAPE)									
10	G5	I	GREEN DATA BIT 5									
11	G4	I	GREEN DATA BIT 4									
12	G3	I	GREEN DATA BIT 3									
13	G2	I	GREEN DATA BIT 2									
14	G1	I	GREEN DATA BIT 1									
15	G0	I	GREEN DATA BIT 0									
16	VSS	P	GROUND (VSS IS CONNECTED TO METAL HOUSING WITH CONDUCTIVE TAPE)									
17	R5	I	RED DATA BIT 5									
18	R4	I	RED DATA BIT 4									
19	R3	I	RED DATA BIT 3									
20	R2	I	RED DATA BIT 2									
21	R1	I	RED DATA BIT 1									
22	R0	I	RED DATA BIT 0									
23	VSS	P	GROUND (VSS IS CONNECTED TO METAL HOUSING WITH CONDUCTIVE TAPE)									
24	DCLK	I	DOT DATA CLOCK									
25	VSS	P	GROUND (VSS IS CONNECTED TO METAL HOUSING WITH CONDUCTIVE TAPE)									
26	HSYNC	I	HORIZONTAL SYNC INPUT	DE MODE : HSYNC, VSYNC FLOATING SYNC MODE : ENB CONNECTED TO GROUND								
27	VSYNC	I	VERTICAL SYNC INPUT									
28	ENB	I	DATA ENABLE INPUT									
29	PWCTRL	I	<table border="1"> <thead> <tr> <th></th> <th>PWCTRL</th> <th>REMARK</th> </tr> </thead> <tbody> <tr> <td rowspan="2">  </td> <td>H</td> <td>POWER ON</td> </tr> <tr> <td>L</td> <td>SHUTDOWN</td> </tr> </tbody> </table>			PWCTRL	REMARK		H	POWER ON	L	SHUTDOWN
				PWCTRL	REMARK							
	H	POWER ON										
	L	SHUTDOWN										
			WHEN INTERNAL LED DRIVER : JP4 1-2(DEFAULT) WHEN EXTERNAL LED DRIVER : JP4 2-3									
30	VDD	P	POWER SUPPLY VOLTAGE									

PIN NO.	SYMBOL	I/O/P	FUNCTION
31	VSS	P	GROUND (VSS IS CONNECTED TO METAL HOUSING WITH CONDUCTIVE TAPE)
32	VSS	P	GROUND (VSS IS CONNECTED TO METAL HOUSING WITH CONDUCTIVE TAPE)
33	VCC	P	POWER SUPPLY FOR LED DRIVER CIRCUIT
34	VCC	P	POWER SUPPLY FOR LED DRIVER CIRCUIT
35	NC	—	NON CONNECTION (USING INTERNAL LED DRIVER) OR ANODE (USING EXTERNAL LED DRIVER) WHEN INTERNAL LED DRIVER : JP1 1-2 (DEFAULT) WHEN EXTERNAL LED DRIVER : JP1 2-3
36	LEDCTRL	I	BRIGHTNESS CONTROL FOR LED BACKLIGHT ; LEDCTRL (USING INTERNAL LED DRIVER) OR CATHODE (USING EXTERNAL LED DRIVER) WHEN INTERNAL LED DRIVER : JP2 1-2 (DEFAULT) JP3 1-2 CONNECT(DEFAULT) WHEN EXTERNAL LED DRIVER : JP2 2-3 JP3 NON CONNECTION
37	YU	—	TOP PANEL
38	XL	—	LIFE PANEL
39	YD	—	BOTTOM PANEL
40	XR	—	RIGHT PANEL
			TOUCH PANEL

11. POWER SUPPLY

11.1 POWER SUPPLY FOR LCM

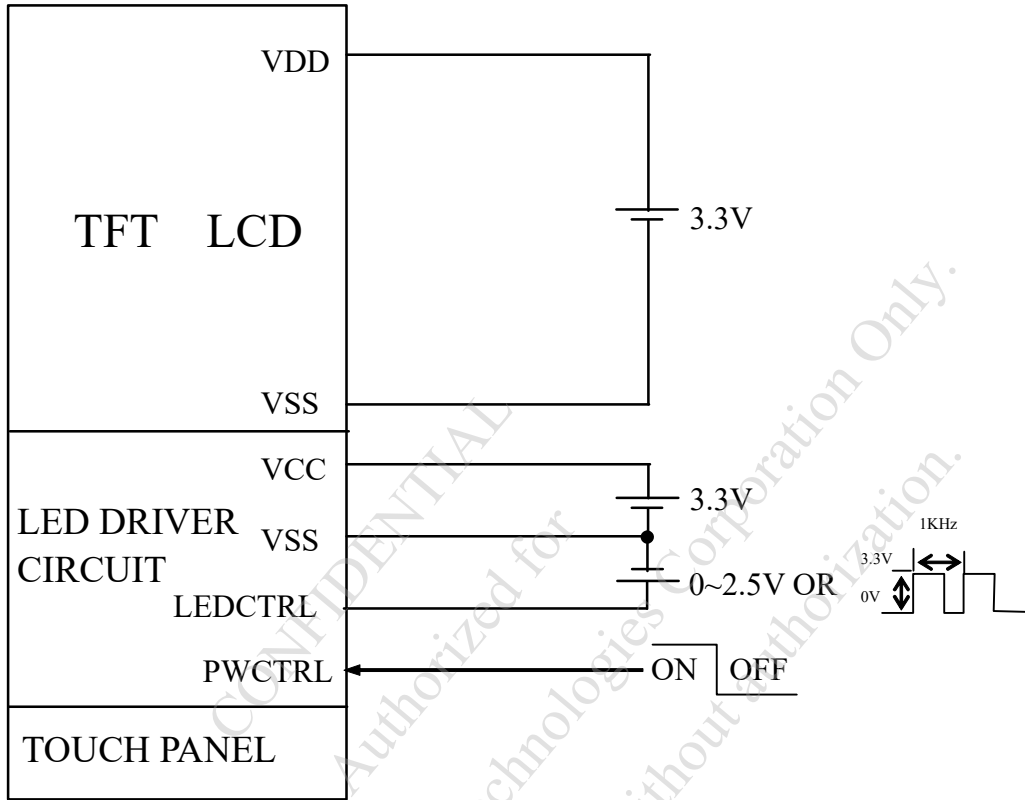

11.2 THE BRIGHTNESS CONTROLLED BY BACKLIGHT CURRENT OF LEDCTRL

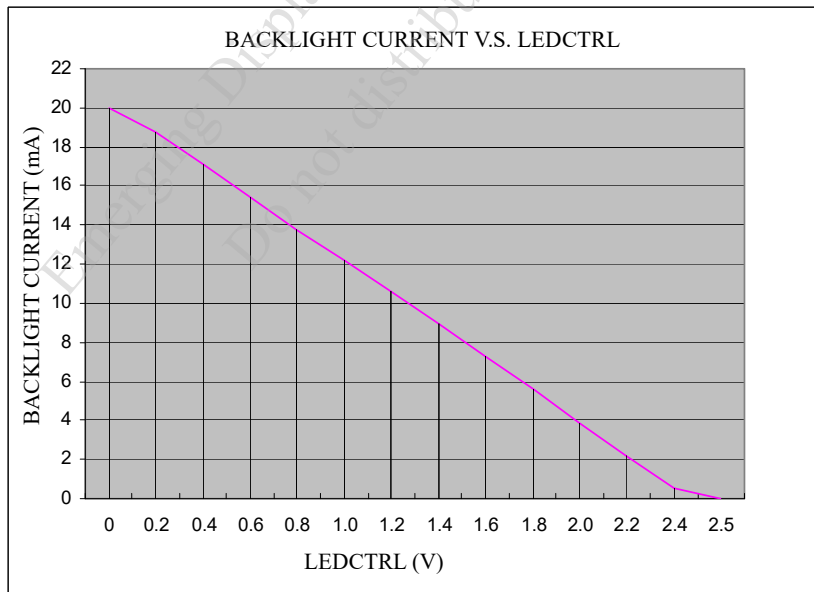

NOTE : LEDCTRL 0~2.5±0.15V

## 12. TOUCH PANEL SPECIFICATION

### 12.1 ELECTRICAL CHARACTERISTICS

Ta = 25°C

ITEM	CONDITION	SPEC.	UNIT
LINEARITY	—	1.5	%
TERMINAL RESISTANCE	X AXIS	200 ~ 900	Ω
	Y AXIS	200 ~ 900	
INSULATION RESISTANCE	DC25V	20	MΩ
INPUT VOLTAGE	—	5(TYP.)	V

### 12.2 PRECAUTIONS IN USE OF TOUCH PANEL

#### 12.2.1 PURPOSE :

IN ORDER TO PREVENT ACCIDENTAL USE AND PERFORMANCE DETERIORATION, PLEASE KEEP THE FOLLOWING PRECAUTIONS AND INHIBITED POINTS.

#### 12.2.2 ITEM AND ILLUSTRATION :

##### ( 1 ) STRUCTURE, AREA DEFINITION

THE STRUCTURE AND THE PERFORMANCE GUARANTEED AREA OF THIS TOUCH PANEL ARE DEFINED BELOW :

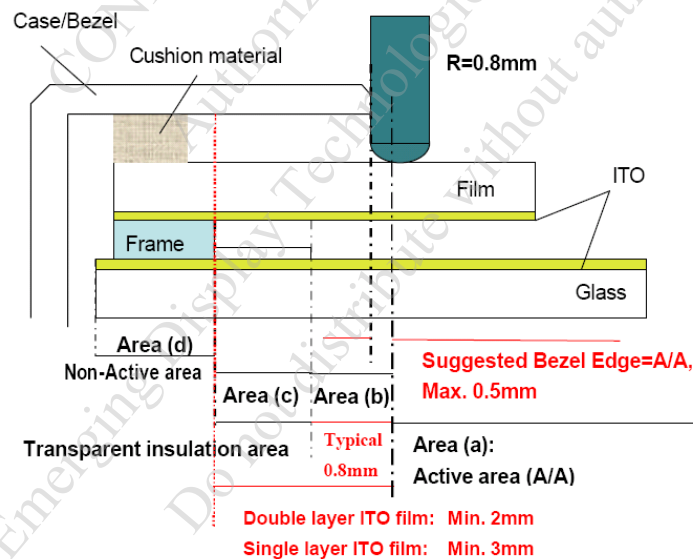

THE ABOVE FIGURE IS OUR DESIGN RULE OF TOUCH PANEL. IF IT CANNOT MEET YOUR REQUIREMENT, PLEASE CONTACT WITH OUR ENGINEERS FOR FURTHER DISCUSSION.

ABOVE FIGURE ILLUSTRATES THE RECOMMENDED BEZEL AND CUSHION DESIGN. IN ORDER TO PREVENT UNUSUAL PERFORMANCE DEGRADATION AND MALFUNCTION OF A TOUCH PANEL, PLEASE CARRY OUT THE SET CASE DESIGNING AND A TOUCH PANEL ASSEMBLING METHOD AFTER SURELY CONSIDERING THE DEFINITION OF EACH AREA ILLUSTRATED IN ABOVE FIGURE.

AREA(a) : ACTIVE AREA

THE ACTIVE AREA IS GUARANTEED THE POSITION DATA DETECTABLE PRECISION, OPERATION FORCE AND OTHER OPERATIONS. IT IS STRONGLY RECOMMENDED TO PLACE THE OPERATION BUTTON OR MENU KEYS WITHIN THE ACTIVE AREA. DUE TO STRUCTURE, THE ACTIVE AREA IS LESS DURABLE AT THE EDGE OR CLOSE TO THE EDGE.

AREA(b) : OPERATION NON-GUARANTEED AREA

THIS AREA DOES NOT GUARANTEE A TOUCH PANEL OPERATION AND ITS FUNCTION. WHEN THIS AREA IS PRESSED, TOUCH PANEL SHOWS DEGRADATION OF ITS PERFORMANCE AND DURABILITY SUCH AS A PEN SLIDING DURABILITY BECOMES ABOUT ONE-TENTH COMPARED WITH THE ACTIVE AREA (AREA-(A) AS GUARANTEED AREA) AND ITS OPERATION FORCE REQUIRES ABOUT DOUBLE. ABOUT 0.5 MM OUTSIDE FROM A BOUNDARY OF THE ACTIVE AREA CORRESPONDS TO THIS AREA.

AREA(c) : PRESSING PROHIBITION AREA

THE AREA WHICH FORBIDS PRESSING, BECAUSE AN EXCESSIVE LOAD IS APPLIED TO A TRANSPARENT ELECTRODE (ITO) AND A SERIOUS DAMAGE IS GIVEN TO A TOUCH PANEL FUNCTION BY PRESSING.

AREA(d) : NON-ACTIVE AREA

THE AREA DOES NOT ACTIVATE EVEN IF PRESSED.

(2) CAUTIONS FOR INSTALLING AND ASSEMBLING

- (i) DO NOT GIVE EXCESSIVE STRAIN TO THE PRODUCT.
- (ii) FLEXIBLE PATTERN CABLE IS CONNECTED TO THE BODY BY THERMAL PRESSURE METHOD. SO, DO NOT APPLY EXCESSIVE FORCES TO THE FLEXIBLE PATTERN. DO NOT ADD AN EXCESSIVE FORCE TO A FPC (FLEX TAIL) THAT MAKES PEELING OFF OF THE FPC FROM THE PRODUCT. DO NOT FIX, ADHERE OR MOUNT ANY ADDITIONAL GOODS ON THE FPC SUCH AS ADDITIONAL FILM/PLATE ON THE FPC, BECAUSE SUCH ADDITIONAL GOODS WILL APPLY A STRESS AT THE FPC BONDING AREA. IT MAY AFFECT THE CONDUCTIVITY OF FPC WITH TOUCH PANEL.
- (iii) IN ORDER NOT TO APPLY LOAD ON THE DISPLAY, PROVIDE A CLEARANCE OF AT LEAST 0.3mm BETWEEN THE PRODUCT AND DISPLAY.

- (iv) WE RECOMMEND THE DESIGN OF A CASE OR BEZEL SHOULD COVERS THE BOUNDARY OF THE ACTIVE AREA INSIDE IN ORDER TO PREVENT AN OPERATION AT OUTSIDE OF THE ACTIVE AREA WHICH CAN NOT GUARANTEE THE FUNCTION OR DURABILITY (REFER TO ITEM 5.1.2. STRUCTURE, AREA DEFINITION).

BEZEL'S EDGE PART MAY GUIDE THE PEN SLIDING ON THE SAME POSITION REPEATEDLY. IF THE BEZEL IS PLACED OUTSIDE OF THE ACTIVE AREA, IT MAY CAUSE THE DAMAGE OF THE ITO FILM.

- (v) PRESSING INSIDE OF BOUNDARY OF THE FRAME(PART (A) AS SHOWN IN BELOW) MAY CAUSES FAULT OPERATION, SO PLEASE DESIGN TO AVOID PRESSING OF TOUCH PANEL AT PART (A) SUCH AS HAVING GASKET/CUSHION AT PART (C). PARTICULARLY THE AREA (B) SHALL BE FREE FROM BURR. THE GASKET/CUSHION MATERIAL AT THE PART (C) SHOULD NOT BE EXCEEDED TO INSIDE OF THE BOUNDARY OF THE FRAME.

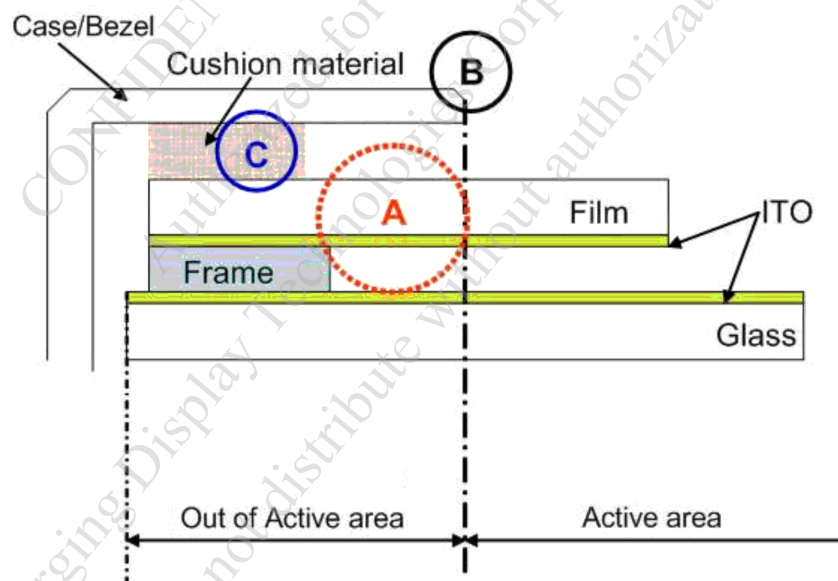

- (vi) TO PREVENT GIVING DISTORTION TO THE FILM OF THE PRODUCT AND PEELING OFF OF THE FILM FROM THE PRODUCT, DO NOT FIX THE FILM AND A SET CASE OR A SHOCK ABSORBING MATERIAL ADHERED TO A SET CASE BY ADHESION.
- (vii) WIPE OFF THE STAIN ON THE PRODUCT BY USING SOFT CLOTH MOISTENED WITH ETHANOL. TAKE CARE NOT TO ALLOW ETHANOL TO SOAK INTO THE JOINT OF UPPER FILM AND BOTTOM GLASS. IT MAY OTHERWISE CAUSE PEELING OR DEFECTIVE OPERATION. DO NOT USE ANY ORGANIC SOLVENT OR DETERGENT OTHER THAN ETHANOL.

- (viii) THE CORNERS OF THE PRODUCT ARE NOT CHAMFERED AND ARE SHARP.  
WHEN POSITIONING AND FIXING THE PRODUCT ON THE CASE, PROVIDE A ROUND PART ON THE CORNER OF THE CASE SO AS NOT TO APPLY LOAD ON THE CORNER OF THE TRANSPARENT TOUCH PANEL.
- (ix) DO NOT PRESS THE FILM OF THE PRODUCT WHEN THIS PRODUCT IS BUILT INTO A SET.

(3) CAUTIONS FOR OPERATION

- (i) OPERATE IT WITH A POLYACETAL PEN (TIP R0.8 OR OVER) OR A BELLY OF A FINGER WITHOUT APPLYING EXCESSIVE LOAD. NEVER USE ANY MECHANICAL PENCILS, BALL POINT PENS AND HARD FINGERTIPS WHO'S TIP IS HARD FOR INPUT, OTHERWISE MALFUNCTIONS MAY RESULT.
- (ii) THE INPUT POSITION MAY BE FLUCTUATED A LITTLE THROUGH LONG-TIME USE. IT IS DESIRABLE TO PROVIDE A ZERO-ADJUSTMENT FUNCTION BY USING A CIRCUIT AND SOFTWARE.
- (iii) OPERATION AT THE OUT OF ACTIVE AREA IS OUT OF OUR GUARANTEE. IT CAUSES A SERIOUS DAMAGE OF A TRANSPARENT ELECTRODE. DO NOT OPERATE AT THE OUT OF ACTIVE AREA.
- (iv) IN CASE OF CLEANING THE PART OF THE CASE BOUNDARY OF ACCOMPLISHED SET, USE A SOFT CLOTH WITH A FINGER BERRY OR A COTTON BUD. DO NOT CLEAN WITH A THING OTHER THAN THE FINGER SUCH AS HARD OR SHARP EDGES LIKE A FINGER NAIL ETC. ON THE CLOTH, BECAUSE IT CAUSE TRANSPARENT CONDUCTIVE FILM CRACKS. PLEASE ADVISE THIS PROHIBITION TO YOUR LAST CUSTOMERS.

12.3 DURABILITY

12.3.1 STYLUS HITTING :

ONE MILLION TIMES OR OVER  
NO DAMAGE ON FILM SURFACE  
PEN : R8 mm SILICON RUBBER  
LOAD : 250g

FREQUENCY : 240 times/min

MEASUREMENT POSITION:

1 POINT OF TOUCH PANEL ACTIVE AREA

REPEATED : OVER 1,000,000 TIMES

12.3.2 PEN TOUCH SLIDING DURABILITY :

100,000 TIMES OR OVER

WRITING WITH R0.8mm PLASTIC STYLUS PEN; WRITING FORCE 150g  
IN ACTIVE AREA.

SPEED IS 60mm/sec.

#### 12.4 STEEL BALL DROP TEST

BY USING F9mm STEEL BALL FROM THE HEIGHT OF 30cm AND FALLING ON TOUCH PANEL SURFACE, MUST PASS BELOW CONDITIONS :

APPEARANCE : THE APPEARANCE WITHOUT ANY CHANGE, INCLUDING THE PANEL BROKEN.

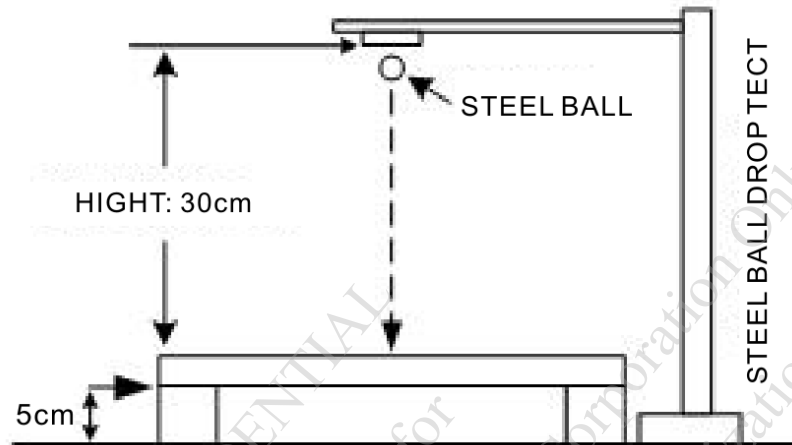

#### 12.5 APPEARANCE INSPECTION

PURPOSE :

TO ESTABLISH APPEARANCE STANDARD AND MAINTAIN PRODUCT QUALITY.

SCOPE :

TOUCH PANEL VIEW AREA WITHIN TOUCH PANEL.

##### 12.5.1 RULE :

INSPECTION CONDITION

(A) ENVIRONMENTAL LUMINANCE : 500 LUX.

(B) DISTANCE BETWEEN HUMAN EYES AND PANEL : 30 cm  
(PANEL MUST BE TESTED UNDER LIGHT TRANSPARENT).

(C) VISUAL ANGEL :  $> 60^\circ$

(D) LIGHT SOURCE : FLUORESCENT LIGHT SOURCE.

##### 12.5.2 JUDGE CRITERION :

JUDGEMENT UNDER ABOVE MENTIONED CRITERION (PANEL MUST BE TESTED UNDER LIGHT TRANSPARENT), TESTING GOODS DEFECT CAN BE VISIBLE WITHIN 10 SECONDS, WHICH WILL BE JUDGED AS MAJOR DEFECTS.

SAMPLING STANDARD :

THE SAMPLING STANDARD WILL BE CONFIRMED BY BOTH OF EDT AND CUSTOMER.

INSPECTION ITEMS	SPEC.	JUDGE CRITERION	OPERATION GUIDELINE
SCRATCH	$W \leq 0.1\text{mm} \ \& \ L \leq 10\text{mm}$	ACCEPTABLE	
	$W > 0.1\text{mm} \ \text{or} \ L > 10\text{mm}$	NOT ACCEPTABLE	
LINEAR FOREIGN OBJECT	$W \leq 0.1\text{mm} \ \& \ L \leq 5\text{mm}$	ACCEPTABLE	
	$W > 0.1\text{mm} \ \text{or} \ L > 5\text{mm}$	NOT ACCEPTABLE	
GRANULAR FOREIGN OBJECT	$D \leq 0.3\text{mm}$	ACCEPTABLE	
	$D > 0.3\text{mm}$	NOT ACCEPTABLE	
PET BUBBLES	$D \leq 0.6\text{mm}$	ACCEPTABLE	
	$D > 0.6\text{mm}$	NOT ACCEPTABLE	
CHIP ON GLASS	CORNER $X \leq 3\text{mm} \ \cdot$ $Y \leq 3\text{mm} \ \cdot$ $Z < t$ $(t = \text{thickness})$	ACCEPTABLE	Chip of glass 
	EDGE $W \leq 3\text{mm} \ \cdot$ $Y \leq 3\text{mm} \ \cdot$ $Z < t$		

13. INSPECTION CRITERION

13.1 APPLICATION

THIS INSPECTION STANDARD IS TO BE APPLIED TO THE LCD MODULE DELIVERED FROM EMERGING DISPLAY TECHNOLOGIES CORP.( E.D.T ) TO CUSTOMERS

13.2 INSPECTION CONDITIONS

13.2.1 (1)OBSERVATION DISTANCE : 45±5cm

(2)VIEWING ANGLE : ±45°

±15° (FOR SECTION WITHIN VIEWING AREA), REFER TO FIG.A

90° (FOR SECTION OUTSIDE OF VIEWING AREA), REF TO FIG.B

PERPENDICULAR TO MODULE SURFACE

VIEWING ANGLE SHOULD BE SMALLER THAN 45°

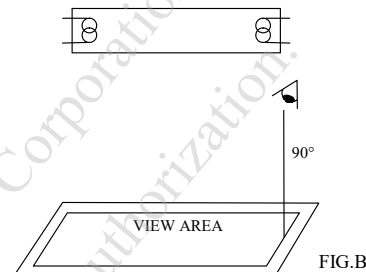
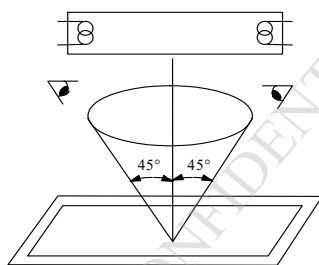

THE INSPECTION CRITERIA IS ACCORDING TO LINE OF SIGHT. INSPECTION SHALL BE MADE WITHIN THE HALF SECTION OF THE VIEWING CONE GENERATED BY LINE SEGMENT OF 45° WITH RESPECTS TO THE VERTICAL AXIS FROM CENTER VERTEX OF LCD, THE FLUORESCENT LAMP AND THE CONE AXIS MUST BE PERPENDICULAR TO THE LCD SURFACE.

IF THE DEFECTS ARE OUTSIDE OF VIEWING AREA, IT SHALL BE INSPECTED BY 90° WITH RESPECTS TO THE VERTICAL AXIS FROM EDGE OF VIEWING AREA.

13.2.2 ENVIRONMENT CONDITIONS :

AMBIENT TEMPERATURE		25±5°C
AMBIENT HUMIDITY		65±20%RH
AMBIENT ILLUMINATION	COSMETIC INSPECTION	600~800 Lux
	FUNCTIONAL INSPECTION	300~500 Lux
INSPECTION TIME		10 secs

13.2.3 INSPECTION LOT

QUANTITY PER DELIVERY LOT FOR EACH MODEL

13.2.4 INSPECTION METHOD

A SAMPLING INSPECTION SHALL BE MADE ACCORDING TO THE FOLLOWING PROVISIONS TO JUDGE THE ACCEPTABILITY

(a)APPLICABLE STANDARD :

ANSI/ ASQ Z1.4 NORMAL INSPECTION LEVEL II

(b)AQL : MAJOR DEFECT : AQL 0.65

MINOR DEFECT : AQL 1.0

13.3 INSPECTION STANDARDS

13.3.1 VISUAL DEFECTS CLASSIFICATION

TYPE OF DEFECT	INSPECTION ITEM	DEFECT FEATURE	AQL
MAJOR DEFECT	1.DISPLAY ON	<ul style="list-style-type: none"> <li>• DEFECT TO MISS SPECIFIED DISPLAY FUNCTION, FOR ALL AND SPECIFIED DOTS</li> <li>EX: DISCONNECTION, SHORT CIRCUIT ETC</li> </ul>	0.65
	2.BACKLIGHT	<ul style="list-style-type: none"> <li>• NO LIGHT</li> <li>• FLICKERING AND OTHER ABNORMAL ILLUMINATION</li> </ul>	
	3.DIMENSIONS	<ul style="list-style-type: none"> <li>• SUBJECT TO INDIVIDUAL ACCEPTANCE SPECIFICATIONS</li> </ul>	
MINOR DEFECT	1.DISPLAY ZONE	<ul style="list-style-type: none"> <li>• BLACK/WHITE SPOT</li> <li>• BUBBLES ON POLARIZER</li> <li>• NEWTON RING</li> <li>• BLACK/WHITE LINE</li> <li>• SCRATCH</li> <li>• CONTAMINATION</li> <li>• UNEVEN COLOR SPREAD</li> </ul>	1.0
	2.BEZEL ZONE	<ul style="list-style-type: none"> <li>• STAINS</li> <li>• SCRATCHES</li> <li>• FOREIGN MATTER</li> </ul>	
	3.SOLDERING	<ul style="list-style-type: none"> <li>• INSUFFICIENT SOLDER</li> <li>• SOLDERED IN INCORRECT POSITION</li> <li>• CONVEX SOLDERING SPOT</li> <li>• SOLDER BALLS</li> <li>• SOLDER SCRAPS</li> </ul>	
	4.DISPLAY ON (ALL ON)	<ul style="list-style-type: none"> <li>• LIGHT LINE</li> </ul>	

13.3.2 MODULE DEFECTS CLASSIFICATION

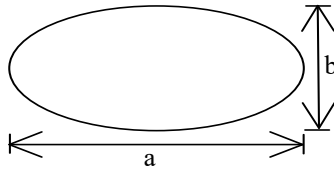
NO.	ITEM	CRITERIA												
1	DISPLAY ON INSPECTION	(1)INCORRECT PATTERN (2)MISSING SEGMENT (3)DIM SEGMENT (4)OPERATING VOLTAGE BEYOND SPEC												
2	OVERALL DIMENSIONS	(1)OVERALL DIMENSION BEYOND SPEC												
3	DOT DEFECT	(1)INSPECTION PATTERN: FULL WHITE, FULL BLACK, RED, GREEN AND BLUE SCREENS. (2) <table border="1" style="margin-left: 20px;"> <thead> <tr> <th>ITEMS</th> <th>ACCEPTABLE COUNT</th> </tr> </thead> <tbody> <tr> <td>BRIGHT DOT</td> <td><math>N \leq 2</math></td> </tr> <tr> <td>DARK DOT</td> <td><math>N \leq 3</math></td> </tr> <tr> <td>TOTAL BRIGHT AND DARK DOTS</td> <td><math>N \leq 4</math></td> </tr> </tbody> </table> <p>NOTE :</p> <p>1. THE DEFINITION OF DOT : THE SIZE OF A DEFECTIVE DOT OVER 1/2 OF WHOLE DOT IS REGARDED AS ONE DEFECTIVE DOT.</p> <p>2. BRIGHT DOT : DOTS APPEAR BRIGHT AND UNCHANGED IN SIZE IN WHICH LCD PANEL IS DISPLAYING UNDER BLACK PATTERN. THE BRIGHT DOT DEFECT MUST BE VISIBLE THROUGH 5% ND FILTER.</p> <p>3. DARK DOT : DOTS APPEAR DARK AND UNCHANGED IN SIZE IN WHICH LCD PANEL IS DISPLAYING UNDER PURE RED, GREEN, BLUE PICTURE.</p>	ITEMS	ACCEPTABLE COUNT	BRIGHT DOT	$N \leq 2$	DARK DOT	$N \leq 3$	TOTAL BRIGHT AND DARK DOTS	$N \leq 4$				
ITEMS	ACCEPTABLE COUNT													
BRIGHT DOT	$N \leq 2$													
DARK DOT	$N \leq 3$													
TOTAL BRIGHT AND DARK DOTS	$N \leq 4$													
4	FOREIGN BLACK/WHITE/ BRIGHT LINE/ SCRATCH OF VIEWING AREA	<table border="1" style="margin-left: 20px;"> <thead> <tr> <th>LENGTH : L</th> <th>WIDTH : W</th> <th>PERMISSIBLE NO.</th> </tr> </thead> <tbody> <tr> <td><math>L \leq 0.3</math></td> <td><math>W \leq 0.05</math></td> <td>IGNORE</td> </tr> <tr> <td><math>0.3 &lt; L \leq 3.0</math></td> <td><math>0.05 &lt; W \leq 0.1</math></td> <td>4</td> </tr> <tr> <td><math>3.0 &lt; L</math></td> <td><math>0.1 &lt; W</math></td> <td>NONE</td> </tr> </tbody> </table> <p>WIDTH : W mm, LENGTH : L mm</p>	LENGTH : L	WIDTH : W	PERMISSIBLE NO.	$L \leq 0.3$	$W \leq 0.05$	IGNORE	$0.3 < L \leq 3.0$	$0.05 < W \leq 0.1$	4	$3.0 < L$	$0.1 < W$	NONE
LENGTH : L	WIDTH : W	PERMISSIBLE NO.												
$L \leq 0.3$	$W \leq 0.05$	IGNORE												
$0.3 < L \leq 3.0$	$0.05 < W \leq 0.1$	4												
$3.0 < L$	$0.1 < W$	NONE												
5	FOREIGN MATTER \ BLACK SPOTS \ WHITE SPOTS \ DENT (INCLUDING LIGHT LEAKAGE DUE TO POLARIZING PLATES PINHOLES, ETC.)	<table border="1" style="margin-left: 20px;"> <thead> <tr> <th>AVERAGE DIAMETER (mm): D</th> <th>NUMBER OF PIECES PERMITTED</th> </tr> </thead> <tbody> <tr> <td><math>D \leq 0.15</math></td> <td>IGNORE</td> </tr> <tr> <td><math>0.15 &lt; D \leq 0.5</math></td> <td>4</td> </tr> <tr> <td><math>0.5 &lt; D</math></td> <td>NONE</td> </tr> </tbody> </table> <p>NOTE : DIAMETER <math>D=(a+b)/2</math></p> 	AVERAGE DIAMETER (mm): D	NUMBER OF PIECES PERMITTED	$D \leq 0.15$	IGNORE	$0.15 < D \leq 0.5$	4	$0.5 < D$	NONE				
AVERAGE DIAMETER (mm): D	NUMBER OF PIECES PERMITTED													
$D \leq 0.15$	IGNORE													
$0.15 < D \leq 0.5$	4													
$0.5 < D$	NONE													

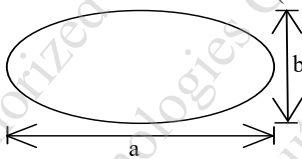
NO.	ITEM	CRITERIA		
			AVERAGE DIAMETER (mm) : D	NUMBER OF PIECES PERMITTED
6	BUBBLES OF POLARIZER /DIRT/DENT /SURFACE STAINS/ CF FAIL	BUBBLE ON THE POLARIZER	$D \leq 0.25$	IGNORE
			$0.25 < D \leq 0.5$	$N \leq 5$
			$0.5 < D$	NONE
		DIRT / DENT / SURFACE STAINS	$D < 0.25$	IGNORE
			$0.25 < D \leq 0.35$	$N \leq 3$
			$0.35 < D$	NONE
		CF FAIL / SPOT	$D < 0.1$	IGNORE
			$0.1 < D \leq 0.3$	$N \leq 3$
			$0.3 < D$	NONE
		<p>NOTE : (1)POLARIZER BUBBLE IS DEFINED AS THE BUBBLE APPEARS ON ACTIVE DISPLAY AREA. THE DEFECT OF POLARIZER BUBBLE SHALL BE IGNORED IF THE POLARIZER BUBBLE APPEARS ON THE OUTSIDE OF ACTIVE DISPLAY AREA.</p> <p>(2)THE EXTRANEIOUS SUBSTANCE IS DEFINED AS IT CAN BE OBSERVED WHEN THE MODULE IS POWER ON.</p> <p>(3)THE DEFINITION OF AVERAGE DIAMETER, D IS DEFINED AS FOLLOWING.</p> <p>AVERAGE DIAMETER (D)=(a+b)/2</p> 		
7	LINE DEFECT ON DISPLAY	OBVIOUS VERTICAL OR HORIZONTAL LINE DEFECT IS NOT ALLOWED		
8	MURA ON DISPLAY	IT'S OK IF MURA IS SLIGHT VISIBLE THROUGH 5% ND FILTER		
9	UNEVEN COLOR SPREAD, COLORATION	(1)TO BE DETERMINED BASED UPON THE STANDARD SAMPLE.		
10	BEZEL APPEARANCE	<p>(1)BEZEL MAY NOT HAVE RUST, BE DEFORMED OR HAVE FINGER PRINTS STAINS OF OTHER CONTAMINATION.</p> <p>(2)BEZEL MUST COMPLY WITH JOB SPECIFICATIONS.</p>		
11	PCB	<p>(1)THERE MAY NOT BE MORE THAN 2mm OF SEALANT OUTSIDE THE SEAL AREA ON THE PCB, AND THERE SHOULD BE NO MORE THAN THREE PLACES.</p> <p>(2)NO OXIDATION OR CONTAMINATION PCB TERMINALS.</p> <p>(3)PARTS ON PCB MUST BE THE SAME AS ON THE PRODUCTION CHARACTERISTIC CHART. THERE SHOULD BE NO WRONG PARTS, MISSING PARTS OR EXCESS PARTS.</p> <p>(4)THE JUMPER ON THE PCB SHOULD CONFORM TO THE PRODUCT CHARACTERISTIC CHART.</p> <p>(5)IF SOLDER GETS ON BEZEL TAB PADS, LED PAD, ZEBRA PAD OR SCREW HOLD PAD, MAKE SURE IT IS SMOOTHED DOWN.</p>		

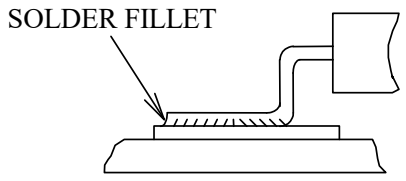
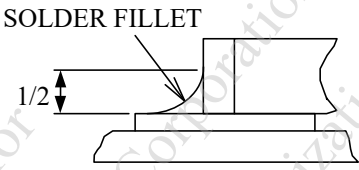
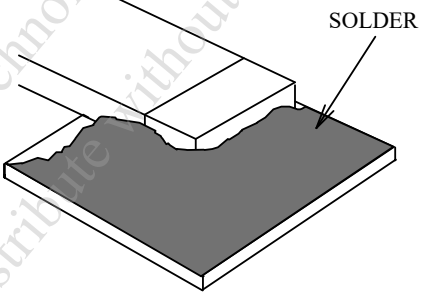
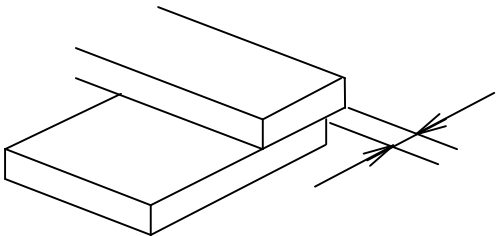
NO.	ITEM	CRITERIA
12	SOLDERING	<p>(1) NO SOLDERING FOUND ON THE SPECIFIED PLACE                      (2) INSUFFICIENT SOLDER</p> <p>(a) LSI, IC                      A POOR WETTING OF SOLDER IS BETWEEN LOWER BEND OR "HEEL" OF LEAD AND PAD</p>  <p>(b) CHIP COMPONENT                      · SOLDER IS LESS THAN 50% OF SIDES AND FRONT FACE WETTING</p>  <p>· SOLDER WETS 3 SIDES OF TERMINAL, BUT LESS THAN 25% OF SIDES AND FRONT SURFACE AREA ARE COVERED</p>  <p>(3) PARTS ALIGNMENT                      (a) LSI, IC                      LEAD WIDTH IS MORE THAN 50% BEYOND PAD OUTLINE</p> 

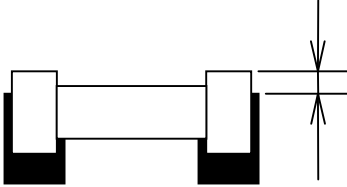
NO.	ITEM	CRITERIA
12	SOLDERING	<p>(b)CHIP COMPONENT COMPONENT IS OFF CENTER, AND MORE THAN 50% OF THE LEADS IS OFF THE PAD OUTLINE</p>  <p>(4)NO UNMELTED SOLDER PASTE MAY BE PRESENT ON THE PCB.            (5)NO COLD SOLDER JOINTS, MISSING SOLDER CONNECTIONS, OXIDATION OR ICICLE.            (6)NO RESIDUE OR SOLDER BALLS ON PCB.            (7)NO SHORT CIRCUITS IN COMPONENTS ON PCB.</p>
13	BACKLIGHT	<p>(1)NO LIGHT            (2)FLICKERING AND OTHER ABNORMAL ILLUMINATION            (3)SPOTS OR SCRATCHES THAT APPEAR WHEN LIT MUST BE JUDGED USING LCD SPOT, LINES AND CONTAMINATION STANDARDS.            (4)BACKLIGHT DOESN'T LIGHT OR COLOR IS WRONG.</p>
14	GENERAL APPEARANCE	<p>(1)NO OXIDATION, CONTAMINATION, CURVES OR, BENDS ON INTERFACE PIN (OLB) OF TCP.            (2)NO CRACKS ON INTERFACE PIN (OLB) OF TCP.            (3)NO CONTAMINATION, SOLDER RESIDUE OR SOLDER BALLS ON PRODUCT.            (4)THE IC ON THE TCP MAY NOT BE DAMAGED, CIRCUITS.            (5)THE UPPERMOST EDGE OF THE PROTECTIVE STRIP ON THE INTERFACE PIN MUST BE PRESENT OR LOOK AS IF IT CAUSE THE INTERFACE PIN TO SEVER.            (6)THE RESIDUAL ROSIN OR TIN OIL OF SOLDERING (COMPONENT OR CHIP COMPONENT) IS NOT BURNED INTO BROWN OR BLACK COLOR.            (7)SEALANT ON TOP OF THE ITO CIRCUIT HAS NOT HARDENED.            (8)PIN TYPE MUST MATCH TYPE IN SPECIFICATION SHEET.            (9)LCD PIN LOOSE OR MISSING PINS.            (10)PRODUCT PACKAGING MUST THE SAME AS SPECIFIED ON PACKAGING SPECIFICATION SHEET.            (11)PRODUCT DIMENSION AND STRUCTURE MUST CONFORM TO PRODUCT SPECIFICATION SHEET.            (12)THE APPEARANCE OF HEAT SEAL SHOULD NOT ADMIT ANY DIRT AND BREAK.</p>

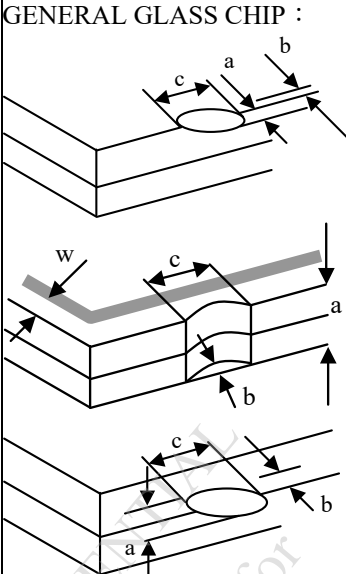
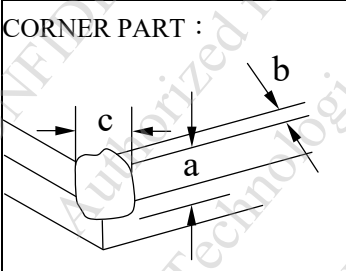
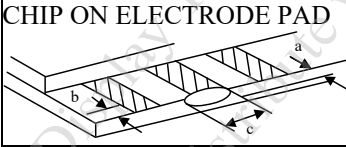
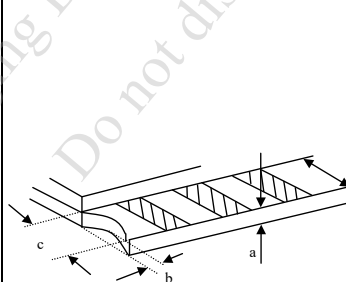
NO.	ITEM	CRITERIA									
15	CRACKED GLASS	<p>THE LCD WITH EXTENSIVE CRACK IS NOT ACCEPTABLE</p> <p>GENERAL GLASS CHIP :</p>  <table border="1"> <thead> <tr> <th>a</th> <th>b</th> <th>c</th> </tr> </thead> <tbody> <tr> <td><math>\leq t/2</math></td> <td>&lt; VIEWING AREA</td> <td><math>\leq 1/8X</math></td> </tr> <tr> <td><math>t/2 &gt; , \leq 2t</math></td> <td><math>\leq W/2</math></td> <td><math>\leq 1/8X</math></td> </tr> </tbody> </table> <p>*W=DISTANCE BETWEEN SEALANT AREA AND LCD PANEL EDGE X = LCD SIDE LENGTH t = GLASS THICKNESS</p>	a	b	c	$\leq t/2$	< VIEWING AREA	$\leq 1/8X$	$t/2 > , \leq 2t$	$\leq W/2$	$\leq 1/8X$
		a	b	c							
		$\leq t/2$	< VIEWING AREA	$\leq 1/8X$							
		$t/2 > , \leq 2t$	$\leq W/2$	$\leq 1/8X$							
		<p>CORNER PART :</p>  <table border="1"> <thead> <tr> <th>a</th> <th>b</th> <th>c</th> </tr> </thead> <tbody> <tr> <td><math>\leq t/2</math></td> <td>&lt; VIEWING AREA</td> <td><math>\leq 1/8X</math></td> </tr> <tr> <td><math>&gt; t/2 , \leq 2t</math></td> <td><math>\leq W/2</math></td> <td><math>\leq 1/8X</math></td> </tr> </tbody> </table> <p>*W=DISTANCE BETWEEN SEALANT AREA AND LCD PANEL EDGE X = LCD SIDE LENGTH t = GLASS THICKNESS</p>	a	b	c	$\leq t/2$	< VIEWING AREA	$\leq 1/8X$	$> t/2 , \leq 2t$	$\leq W/2$	$\leq 1/8X$
a	b	c									
$\leq t/2$	< VIEWING AREA	$\leq 1/8X$									
$> t/2 , \leq 2t$	$\leq W/2$	$\leq 1/8X$									
<p>CHIP ON ELECTRODE PAD</p>  <table border="1"> <thead> <tr> <th>a</th> <th>b</th> <th>c</th> </tr> </thead> <tbody> <tr> <td><math>\leq t</math></td> <td><math>\leq 0.5\text{mm}</math></td> <td><math>\leq 1/8X</math></td> </tr> </tbody> </table> <p>* X=LCD SIDE WIDTH t=GLASS THICKNESS</p>	a	b	c	$\leq t$	$\leq 0.5\text{mm}$	$\leq 1/8X$					
a	b	c									
$\leq t$	$\leq 0.5\text{mm}$	$\leq 1/8X$									
 <table border="1"> <thead> <tr> <th>a</th> <th>b</th> <th>c</th> </tr> </thead> <tbody> <tr> <td><math>\leq t</math></td> <td><math>\leq 1/8X</math></td> <td><math>\leq L</math></td> </tr> </tbody> </table> <p>*X=LCD SIDE WIDTH t = GLASS THICKNESS L=ELECTRODE PAD LENGTH</p> <p>①IF GLASS CHIPPING THE ITO TERMINAL, OVER 2/3 OF THE ITO MUST REMAIN AND BE, INSPECTED ACCORDING TO ELECTRODE TERMINAL SPECIFICATIONS</p> <p>②IF THE PRODUCT WILL BE HEAT SEALED BY THE CUSTOMER, THE ALIGNMENT MARK MUST NOT BE DAMAGED</p>	a	b	c	$\leq t$	$\leq 1/8X$	$\leq L$					
a	b	c									
$\leq t$	$\leq 1/8X$	$\leq L$									

14. RELIABILITY TEST

14.1 STANDARD SPECIFICATIONS FOR RELIABILITY OF LCD MODULE

NO.	ITEM	DESCRIPTION
1	HIGH TEMPERATURE TEST (OPERATION)	THE SAMPLE SHOULD BE ALLOWED TO STAND AT +70°C FOR 240 HRS
2	LOW TEMPERATURE TEST (OPERATION)	THE SAMPLE SHOULD BE ALLOWED TO STAND AT -20°C FOR 240 HRS
3	HIGH TEMPERATURE TEST (STORAGE)	THE SAMPLE SHOULD BE ALLOWED TO STAND AT +80°C FOR 240 HRS
4	LOW TEMPERATURE TEST (STORAGE)	THE SAMPLE SHOULD BE ALLOWED TO STAND AT -30°C FOR 240 HRS
5	HIGH TEMPERATURE / HUMIDITY TEST (STORAGE)	THE SAMPLE SHOULD BE ALLOWED TO STAND AT 60°C , 90% RH 240 HRS
6	THERMAL SHOCK TEST (NOT OPERATED)	<p>THE SAMPLE SHOULD BE ALLOWED TO STAND THE FOLLOWING 10 CYCLES OF OPERATION:</p>
7	VIBRATION (NOT OPERATED)	11.76 m/s <sup>2</sup> (1.2G), 10~100 Hz XYZ DIRECTIONS, 1 HR EACH
8	SHOCK (NOT OPERATED)	490.0 m/s <sup>2</sup> (50G), 10 ms XYZ DIRECTIONS, 1 TIME EACH
9	ESD (ELECTROSTATIC DISCHARGE) (NON-OPERATION)	AIR DISCHARGE ± 12KV CONTACT DISCHARGE ± 8KV (ACCORDING TO IEC-61000-4-2)

NOTE ( 1 ) : THE TEST SAMPLES HAVE RECOVERY TIME FOR 2 HOURS AT ROOM TEMPERATURE BEFORE THE FUNCTION CHECK. IN THE STANDARD CONDITIONS, THERE IS NO DISPLAY FUNCTION NG ISSUE OCCURRED.

NOTE ( 2 ) : THERE IS NO DISPLAY FUNCTION NG ISSUE OCCURRED, ALL THE COSMETIC SPECIFICATION IS JUDGED BEFORE THE RELIABILITY STRESS.

NOTE ( 3 ) : THE MODULE SHOULDN'T BE TESTED MORE THAN ONE CONDITION, AND ALL THE TEST CONDITIONS ARE INDEPENDENT.

NOTE ( 4 ) : TESTING CONDITIONS AND INSPECTION CRITERIA

NO.	ITEM	TEST MODEL	INSPECTION CRITERIA
1	CURRENT CONSUMPTION	REFER TO SPECIFICATION	THE CURRENT CONSUMPTION SHOULD CONFORM TO THE PRODUCT SPECIFICATION.
2	CONTRAST	REFER TO SPECIFICATION	AFTER THE TESTS HAVE BEEN EXECUTED, THE CONTRAST MUST BE LARGER THAN HALF OF ITS INITIAL VALUE PRIOR TO THE TESTS.
3	APPEARANCE	VISUAL INSPECTION	DEFECT FREE

## 15. CAUTION

### 15.1 OPERATION

- 15.1.1 DO NOT CONNECT OR DISCONNECT MODULES TO OR FROM THE MAIN SYSTEM WHILE POWER IS BEING SUPPLIED .
- 15.1.2 USE THE MODULE WITHIN SPECIFIED TEMPERATURE ; LOWER TEMPERATURE CAUSES THE RETARDATION OF BLINKING SPEED OF THE DISPLAY ; HIGHER TEMPERATURE MAKES OVERALL DISPLAY DISCOLOR. WHEN THE TEMPERATURE RETURNS TO NORMALITY, THE DISPLAY WILL OPERATE NORMALLY .
- 15.1.3 ADJUST THE LC DRIVING VOLTAGE TO OBTAIN THE OPTIMUM CONTRAST.
- 15.1.4 POWER ON SEQUENCE INPUT SIGNALS SHOULD NOT BE SUPPLIED TO LCD MODULE BEFORE POWER SUPPLY VOLTAGE IS APPLIED AND REACHES THE SPECIFIED VALUE .  
IF ABOVE SEQUENCE IS NOT FOLLOWED , CMOS LSIS OF LCD MODULES MAY BE DAMAGED DUE TO LATCH - UP PROBLEM .
- 15.1.5 NOT ALLOWED TO INFLICT ANY EXTERNAL STRESS AND TO CAUSE ANY MECHANICAL INTERFERENCE ON THE BENDING AREA OF FPC DURING THE TAIL BENDING BACKWARDS!  
DO NOT STRESS FPC AND IC ON THE MODULE!

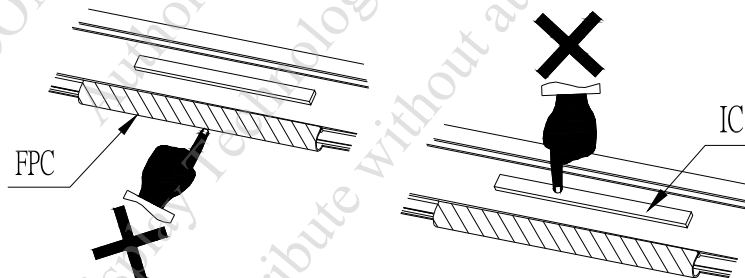

### 15.2 STORAGE

- 15.2.1 STORE THE MODULE IN A DARK ROOM OR KEEP IN ORIGINAL PACKAGE WHERE MUST KEEP AT  $25\pm 10^{\circ}\text{C}$  AND 65%RH OR LESS.
- 15.2.2 DO NOT STORE THE MODULE IN SURROUNDINGS CONTAINING ORGANIC SOLVENT OR CORROSIVE GAS.
- 15.2.3 STORE THE MODULE IN AN ANTI-ELECTROSTATIC CONTAINER OR BAG.

### 15.3 NOTICE

- 15.3.1 USE A GROUNDED SOLDERING IRON WHEN SOLDERING CONNECTOR I/O TERMINALS . FOR SOLDERING OR REPAIRING, TAKE PRECAUTION AGAINST THE TEMPERATURE OF THE SOLDERING IRON AND THE SOLDERING TIME TO PREVENT PEELING OFF THE THROUGH-HOLE-PAD.
- 15.3.2 DO NOT DISASSEMBLE . EDT SHALL NOT BE HELD RESPONSIBLE IF THE MODULE IS DISASSEMBLED AND UPON THE REASSEMBLY THE MODULE FAILED .
- 15.3.3 DO NOT CHARGE STATIC ELECTRICITY , AS THE CIRCUIT OF THIS MODULE CONTAINS CMOS LSIS. A WORKMAN'S BODY SHOULD ALWAYS BE STATIC-PROTECTED BY USE OF AN ESD STRAP. WORKING CLOTHES FOR SUCH PERSONNEL SHOULD BE OF STATIC-PROTECTED MATERIAL .
- 15.3.4 ALWAYS GROUND THE ELECTRICALLY-POWERED DRIVER BEFORE USING IT TO INSTALL THE LCD MODULE. WHILE CLEANING THE WORK STATION BY VACUUM CLEANER, DO NOT BRING THE SUCKING MOUTH NEAR THE MODULE ; STATIC ELECTRICITY OF THE ELECTRICALLY-POWERED DRIVER OR THE VACUUM CLEANER MAY DESTROY THE MODULE .
- 15.3.5 DON'T GIVE EXTERNAL SHOCK.
- 15.3.6 DON'T APPLY EXCESSIVE FORCE ON THE SURFACE.
- 15.3.7 LIQUID CRISTAL IN LCD IS HAZARDOUS SUBSTANCE. MUST NOT LICK AND SWALLOW.  
WHEN THE LIQUID IS ATTACH TO YOUR, SKIN, CLOTH ETC.  
WASH IT OUT THOROUGHLY AND IMMEDIATELY.
- 15.3.8 DON'T OPERATE IT ABOVE THE ABSOLUTE MAXIMUM RATING.
- 15.3.9 STORAGE IN A CLEAN ENVIRONMENT, FREE FROM DUST, ACTIVE GAS, AND SOLVENT.
- 15.3.10 STORE WITHOUT ANY PHYSICAL LOAD.
- 15.3.11 REWIRING: NO MORE THAN 3 TIMES.