

EXAMINED BY :	EMERGING DISPLAY TECHNOLOGIES CORPORATION	FILE NO . CAS-0008575
Sam Chou		ISSUE : FEB.24, 2025
APPROVED BY:		TOTAL PAGE : 23
<i>Elvis Wu</i>		VERSION : 4

CUSTOMER ACCEPTANCE SPECIFICATIONS

MODEL NO. :

ET035012DM6

(RoHS)

FOR MESSRS : _____

CUSTOMER'S APPROVAL

DATE :

BY :

RECORDS OF REVISION		DOC . FIRST ISSUE	JAN.10, 2018																																																																																													
DATE	REVISED PAGE NO.	SUMMARY																																																																																														
FEB.05, 2018	2	3.1 ELECTRICAL ABSOLUTE MAXIMUM RATINGS LED BACKLIGHT POWER DISSIPATION : MAX.=648→558																																																																																														
	3	4. ELECTRICAL CHARACTERISTICS POWER SUPPLY FOR LED BACKLIGHT : MIN.=18.0→16.8, TYP.=19.8→18.0, MAX.=21.6→18.6																																																																																														
	5	5.2 PARALLEL RGB INTERFACE (SYNC MODE) ADD DATA TRANSACTION TIMING IN NORMAL OPERATING MODE																																																																																														
	6	5.3 PARALLEL RGB INTERFACE (DE MODE) CHANGE DATA TRANSACTION TIMING IN NORMAL OPERATING MODE→DATA TRANSACTION TIMING IN DE ONLY OPERATING MODE																																																																																														
SEP.06, 2021	9	7. OUTLINE DIMENSIONS MARK Δ : REMOVE LCM BACKSIDE LABEL MODIFY FPC COMPONENT AREA& INSULATED TAPE OUTLINE																																																																																														
FEB.24, 2025	1	1.2 MATERIAL SAFETY DESCRIPTION ASSEMBLIES SHALL COMPLY WITH EUROPEAN ROHS REQUIREMENTS, INCLUDING PROHIBITED MATERIALS/COMPONENTS CONTAINING LEAD, MERCURY, CADMIUM, HEXAVALENT CHROMIUM, POLYBROMINATED BIPHENYLS (PBB) AND POLYBROMINATED DIPHENYL ETHERS (PBDE) ↓ ASSEMBLIES SHALL COMPLY WITH EUROPEAN ROHS REQUIREMENTS, INCLUDING PROHIBITED MATERIALS/COMPONENTS CONTAINING LEAD, MERCURY, CADMIUM, HEXAVALENT CHROMIUM, POLYBROMINATED BIPHENYLS (PBB) AND POLYBROMINATED DIPHENYL ETHERS (PBDE), BIS(2-ETHYLHEXYL) PHTHALATE (DEHP), BUTYL BENZYL PHTHALATE (BBP), DIBUTYL PHTHALATE (DBP), DIISOBUTYL PHTHALATE (DIBP).																																																																																														
	7	6.1 OPTICAL CHARACTERISTICS <table border="1"> <thead> <tr> <th>ITEM</th> <th>SYMBOL</th> <th>CONDITION</th> <th>MIN.</th> <th>TYP.</th> <th>MAX.</th> <th>UNIT</th> <th>REMARK</th> </tr> </thead> <tbody> <tr> <td rowspan="8">COLOR OF CIE COORDINATE</td> <td rowspan="2">WHITE</td> <td>Wx</td> <td>0.260</td> <td>0.310</td> <td>0.360</td> <td rowspan="8">—</td> <td rowspan="8">NOTE (6)</td> </tr> <tr> <td>Wy</td> <td>0.260</td> <td>0.310</td> <td>0.360</td> </tr> <tr> <td rowspan="2">RED</td> <td>Rx</td> <td>0.562</td> <td>0.612</td> <td>0.662</td> </tr> <tr> <td>Ry</td> <td>0.305</td> <td>0.355</td> <td>0.405</td> </tr> <tr> <td rowspan="2">GREEN</td> <td>Gx</td> <td>0.262</td> <td>0.312</td> <td>0.362</td> </tr> <tr> <td>Gy</td> <td>0.533</td> <td>0.583</td> <td>0.633</td> </tr> <tr> <td rowspan="2">BLUE</td> <td>Bx</td> <td>0.090</td> <td>0.140</td> <td>0.190</td> </tr> <tr> <td>By</td> <td>0.020</td> <td>0.070</td> <td>0.120</td> </tr> </tbody> </table> <p style="text-align: center;">↓</p> <table border="1"> <thead> <tr> <th>ITEM</th> <th>SYMBOL</th> <th>CONDITION</th> <th>MIN.</th> <th>TYP.</th> <th>MAX.</th> <th>UNIT</th> <th>REMARK</th> </tr> </thead> <tbody> <tr> <td rowspan="8">COLOR OF CIE COORDINATE</td> <td rowspan="2">WHITE</td> <td>Wx</td> <td>0.24</td> <td>0.29</td> <td>0.34</td> <td rowspan="8">—</td> <td rowspan="8">NOTE (6)</td> </tr> <tr> <td>Wy</td> <td>0.28</td> <td>0.33</td> <td>0.38</td> </tr> <tr> <td rowspan="2">RED</td> <td>Rx</td> <td>0.56</td> <td>0.61</td> <td>0.66</td> </tr> <tr> <td>Ry</td> <td>0.31</td> <td>0.36</td> <td>0.41</td> </tr> <tr> <td rowspan="2">GREEN</td> <td>Gx</td> <td>0.28</td> <td>0.33</td> <td>0.38</td> </tr> <tr> <td>Gy</td> <td>0.56</td> <td>0.61</td> <td>0.66</td> </tr> <tr> <td rowspan="2">BLUE</td> <td>Bx</td> <td>0.10</td> <td>0.15</td> <td>0.20</td> </tr> <tr> <td>By</td> <td>0.05</td> <td>0.10</td> <td>0.15</td> </tr> </tbody> </table>		ITEM	SYMBOL	CONDITION	MIN.	TYP.	MAX.	UNIT	REMARK	COLOR OF CIE COORDINATE	WHITE	Wx	0.260	0.310	0.360	—	NOTE (6)	Wy	0.260	0.310	0.360	RED	Rx	0.562	0.612	0.662	Ry	0.305	0.355	0.405	GREEN	Gx	0.262	0.312	0.362	Gy	0.533	0.583	0.633	BLUE	Bx	0.090	0.140	0.190	By	0.020	0.070	0.120	ITEM	SYMBOL	CONDITION	MIN.	TYP.	MAX.	UNIT	REMARK	COLOR OF CIE COORDINATE	WHITE	Wx	0.24	0.29	0.34	—	NOTE (6)	Wy	0.28	0.33	0.38	RED	Rx	0.56	0.61	0.66	Ry	0.31	0.36	0.41	GREEN	Gx	0.28	0.33	0.38	Gy	0.56	0.61	0.66	BLUE	Bx	0.10	0.15	0.20	By	0.05	0.10
ITEM	SYMBOL	CONDITION	MIN.	TYP.	MAX.	UNIT	REMARK																																																																																									
COLOR OF CIE COORDINATE	WHITE	Wx	0.260	0.310	0.360	—	NOTE (6)																																																																																									
		Wy	0.260	0.310	0.360																																																																																											
	RED	Rx	0.562	0.612	0.662																																																																																											
		Ry	0.305	0.355	0.405																																																																																											
	GREEN	Gx	0.262	0.312	0.362																																																																																											
		Gy	0.533	0.583	0.633																																																																																											
	BLUE	Bx	0.090	0.140	0.190																																																																																											
		By	0.020	0.070	0.120																																																																																											
ITEM	SYMBOL	CONDITION	MIN.	TYP.	MAX.	UNIT	REMARK																																																																																									
COLOR OF CIE COORDINATE	WHITE	Wx	0.24	0.29	0.34	—	NOTE (6)																																																																																									
		Wy	0.28	0.33	0.38																																																																																											
	RED	Rx	0.56	0.61	0.66																																																																																											
		Ry	0.31	0.36	0.41																																																																																											
	GREEN	Gx	0.28	0.33	0.38																																																																																											
		Gy	0.56	0.61	0.66																																																																																											
	BLUE	Bx	0.10	0.15	0.20																																																																																											
		By	0.05	0.10	0.15																																																																																											
	14	12.2.4 (a)APPLICABLE STANDARD : MIL-STD-105E LEVEL II NORMAL INSPECTION, SINGLE SAMPLING→ ANSI/ ASQ Z1.4 NORMAL INSPECTION LEVEL II																																																																																														

TABLE OF CONTENTS

NO.	ITEM	PAGE
1.	GENERAL SPECIFICATIONS -----	1
2.	MECHANICAL SPECIFICATIONS -----	1
3.	ABSOLUTE MAXIMUM RATINGS -----	2
4.	ELECTRICAL CHARACTERISTICS -----	3
5.	TIMING CHARACTERISTICS -----	4 ~ 6
6.	OPTICAL CHARACTERISTICS -----	7, 8
7.	OUTLINE DIMENSIONS -----	9
8.	BLOCK DIMENSION -----	10
9.	DETAIL DRAWING OF DOT MATRIX -----	11
10.	INTERFACE SIGNALS -----	12, 13
11.	POWER SUPPLY -----	13
12.	INSPECTION CRITERION -----	14 ~ 23

CONFIDENTIAL
Authorized for Emerging Display Technologies Corporation Only.
Do not distribute without authorization.

1. GENERAL SPECIFICATIONS

1.1 DATA SHEET FOR CONTROLLER/DRIVER

PLEASE REFER TO :

HIMAX HX8238-D

1.2 MATERIAL SAFETY DESCRIPTION

ASSEMBLIES SHALL COMPLY WITH EUROPEAN ROHS REQUIREMENTS, INCLUDING PROHIBITED MATERIALS/COMPONENTS CONTAINING LEAD, MERCURY, CADMIUM, HEXAVALENT CHROMIUM, POLYBROMINATED BIPHENYLS (PBB) AND POLYBROMINATED DIPHENYL ETHERS (PBDE), BIS(2-ETHYLHEXYL) PHTHALATE (DEHP), BUTYL BENZYL PHTHALATE (BBP), DIBUTYL PHTHALATE (DBP), DIISOBUTYL PHTHALATE (DIBP).

2. MECHANICAL SPECIFICATIONS

- (1) DISPLAY SIZE ----- 3.5 inch
- (2) NUMBER OF DOTS ----- 320W * (RGB) * 240H DOTS
- (3) MODULE SIZE ----- 76.8W * 63.8H * 3.3D mm
(WITHOUT FPC & PULL TAPE)
- (4) ACTIVE AREA ----- 70.08W * 52.56H mm
- (5) DOT SIZE ----- 0.073W * 0.219H mm
- (6) PIXEL SIZE ----- 0.219W * 0.219H mm
- (7) LCD TYPE ----- TFT , TRANSMISSIVE
- (8) COLOR ----- 16.7M
- (9) VIEWING DIRECTION ----- 6 O'CLOCK (GRAY LEVEL INVERSION)
- (10) BACK LIGHT ----- LED , COLOR : WHITE
- (11) INTERFACE MODE ----- RGB 24BIT PARALLEL (DE/SYNC MODE)

3. ABSOLUTE MAXIMUM RATINGS

3.1 ELECTRICAL ABSOLUTE MAXIMUM RATINGS

ITEM	SYMBOL	MIN.	MAX.	UNIT	REMARK
POWER SUPPLY VOLTAGE	VDD-VSS	VSS-0.3	3.96	V	—
	VCC-VSS	VSS-0.3	4.0	V	—
STATIC ELECTRICITY	—	—	—	V	NOTE (1)
LED BACKLIGHT POWER DISSIPATION	PD	—	558	mW	—
LED BACKLIGHT FORWARD CURRENT	IF	—	30	mA	—
LED BACKLIGHT REVERSE VOLTAGE	VR	—	30	V	—

NOTE (1) : LCM SHOULD BE GROUND DURING HANDLING LCM.

3.2 ENVIRONMENTAL ABSOLUTE MAXIMUM RATINGS

ITEM	OPERATING		STORAGE		REMARK
	MIN.	MAX.	MIN.	MAX.	
AMBIENT TEMPERATURE	-20°C	70°C	-30°C	80°C	NOTE (1) , (2)
HUMIDITY	NOTE (3)		NOTE (3)		WITHOUT CONDENSATION
VIBRATION	—	2.45m/s ² (0.25G)	—	11.76m/s ² (1.2G)	5~20Hz , 1HR 20~500Hz(20Hz) , 1HR 20~500Hz(500Hz) , 1HR X,Y,Z,TOTAL 3HRS
SHOCK	—	29.4m/s ² (3G)	—	490m/s ² (50G)	10 ms XYZ DIRECTIONS 1 TIME EACH
CORROSIVE GAS	NOT ACCEPTABLE		NOT ACCEPTABLE		

NOTE (1) : Ta AT -30°C : WILL BE 48HRS MAX .

80°C : WILL BE 168HRS MAX .

NOTE (2) : BACKGROUND COLOR CHANGES SLIGHTLY DEPENDING ON AMBIENT TEMPERATURE THIS PHENOMENON IS REVERSIBLE .

NOTE (3) : Ta ≤ 60°C : 90%RH MAX (96HRS MAX).

Ta > 60°C : ABSOLUTE HUMIDITY MUST BE LOWER THAN THE HUMIDITY OF 90%RH AT 60°C(96HRS MAX).

4. ELECTRICAL CHARACTERISTICS

Ta = 25 °C

ITEM	SYMBOL	CONDITION	MIN.	TYP.	MAX.	UNIT	REMARK
ANALOG POWER SUPPLY	VDD-VSS	—	2.5	3.3	3.6	V	
DIGITAL POWER SUPPLY	VCC-VSS	—	2.5	3.3	3.6	V	
LOGIC HIGH INPUT VOLTAGE	VIH	H LEVEL	0.8*VCC	—	VCC	V	NOTE (1)
LOGIC LOW INPUT VOLTAGE	VIL	L LEVEL	0	—	0.2*VCC	V	NOTE (1)
ANALOG OPERATING CURRENT	IDD	VDD-VSS=3.3V	—	10	15	mA	NOTE (2)
DIGITAL OPERATING CURRENT	ICC	VCC-VSS=3.3V	—	1	2	mA	NOTE (2)
POWER SUPPLY FOR LED BACKLIGHT	VLED-VLSS	IF=20mA	16.8	18.0	18.6	V	NOTE (1)
LED LIFE TIME	—	IF=20mA	30K	40K	—	HRS	NOTE (5) NOTE (6)

NOTE (1) : APPLIED TO TERMINALS /RESET, B7~B0, G7~G0, R7~R0, DCLK, HSYNC, VSYNC, ENB, SHUT.

NOTE (2) : THE DISPLAY PATTERN IS ALL "WHITE".

NOTE (3) : INTERNAL CIRCUIT DIAGRAM OF BACKLIGHT

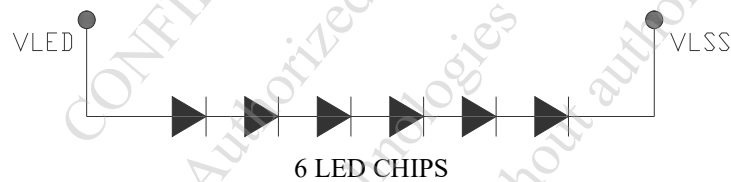

NOTE (4) : AMBIENT TEMP .VS. ALLOWABLE FORWARD CURRENT.(PER LED)

Forward current derating curve VS.Ambient temperature

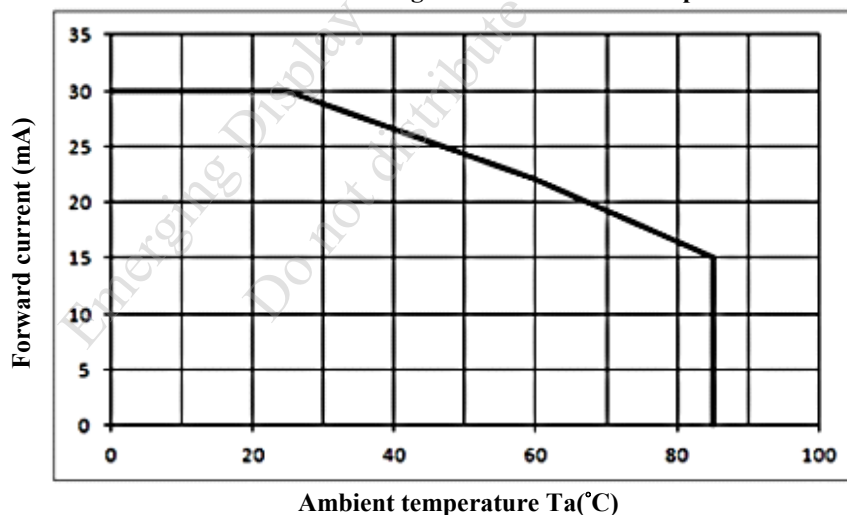

NOTE (5) : CONDITIONS; TA=25 °C, CONTINUOUS LIGHTING.

NOTE (6) : DEFINITIONS OF LIFE TIME :

LCM LUMINANCE BECOMES HALF OF THE INITIAL VALUE.

5. TIMING CHARACTERISTICS

5.1 PIXEL TIMING

ITEM	SYMBOL	MIN.	TYP.	MAX.	UNIT
DOTCLK FREQUENCY	fDOTCLK	—	6.5	10	MHz
DOTCLK PERIOD	tDOTCLK	100	154	—	ns
VERTICAL SYNC SETUP TIME	tvsys	20	—	—	ns
VERTICAL SYNC HOLD TIME	tvsyh	20	—	—	ns
HORIZONTAL SYNC SETUP TIME	thsys	20	—	—	ns
HORIZONTAL SYNC HOLD TIME	thsyh	20	—	—	ns
PHASE DIFFERENCE OF SYNC SIGNAL FALLING EDGE	thv	1	—	240	tDOTCLK
DOTCLK LOW PERIOD	tCKL	50	—	—	ns
DOTCLK HIGH PERIOD	tCKH	50	—	—	ns
DATA SETUP TIME	tds	12	—	—	ns
DATA HOLD TIME	tdh	12	—	—	ns
RESET PULSE WIDTH	tRES	10	—	—	μs

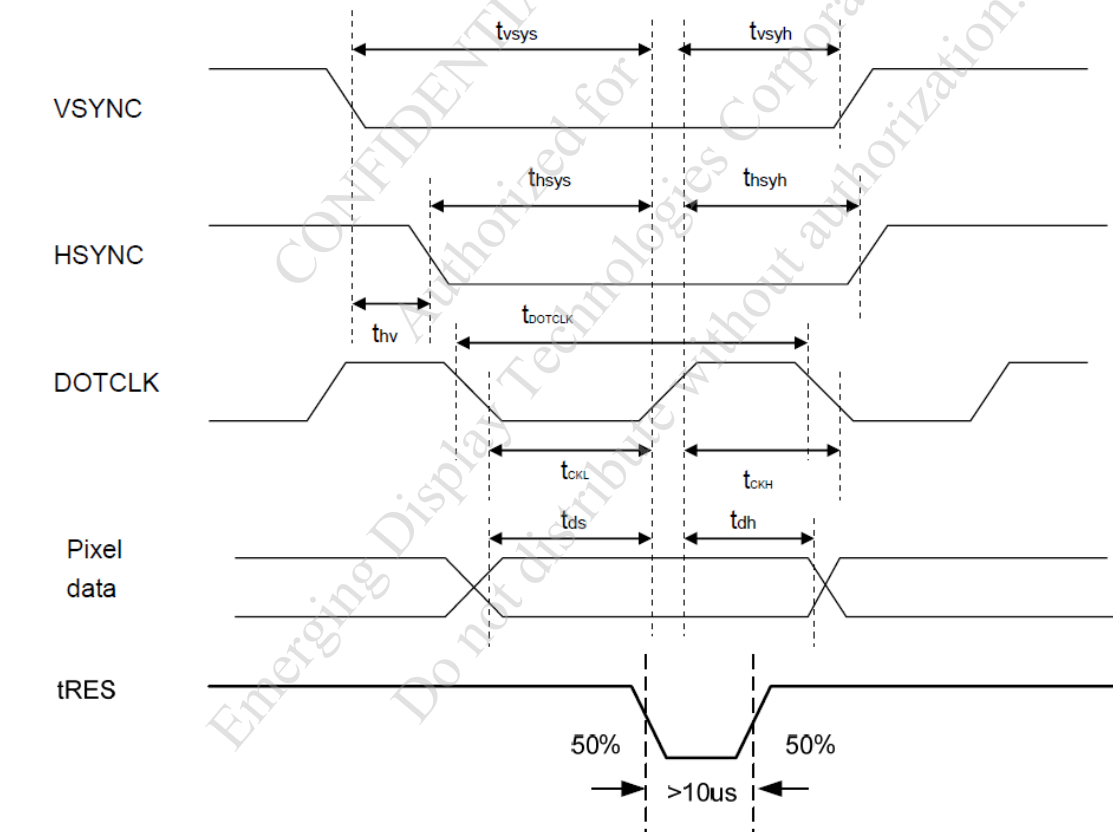

RESET TIMING



5.2 PARALLEL RGB INTERFACE (SYNC MODE)

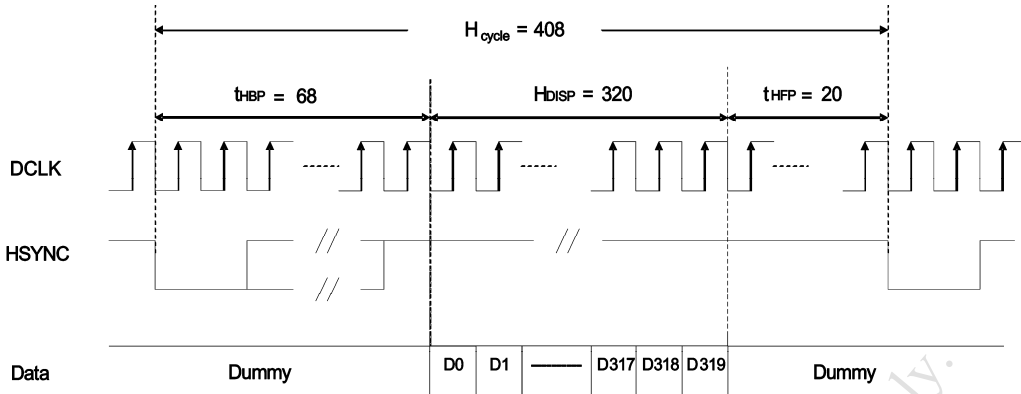

HORIZONTAL DATA TRANSACTION TIMING

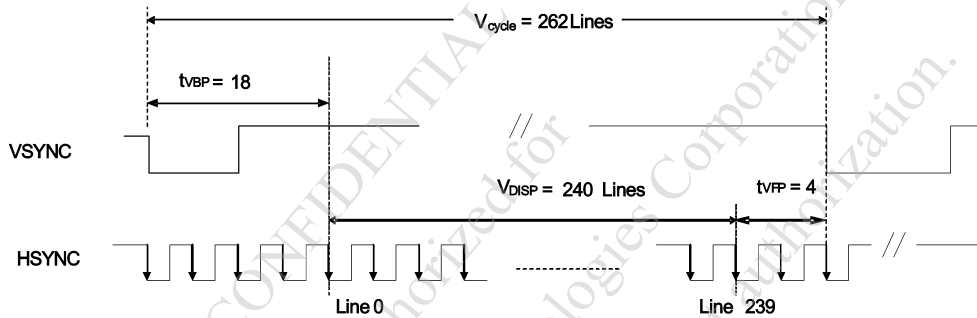

VERTICAL DATA TRANSACTION TIMING

ITEM	SYMBOL	MIN.	TYP.	MAX.	UNIT	
DCLK FREQUENCY	fDCLK	—	6.5	10	MHz	
DCLK PERIOD	tDCLK	100	154	—	ns	
HORIZONTAL FREQUENCY (LINE)	fH	—	15.75	22.35	KHz	
VERTICAL FREQUENCY (REFRESH)	fV	—	60	90	Hz	
HORIZONTAL BACK PORCH	tHBP	—	68	—	tDCLK	
HORIZONTAL FRONT PORCH	tHFP	—	20	—	tDCLK	
HSYNC LOW PULSE WIDTH	tWH	2	32	—	tDOTCLK	
HORIZONTAL DATA START POINT	tHBP	9	68	127	tDCLK	
HORIZONTAL BLANKING PERIOD	tHBP + tHFP	52	88	180	tDCLK	
HORIZONTAL DISPLAY AREA	HDISP	—	320	—	tDCLK	
HORIZONTAL CYCLE	Hcycle	350	408	450	tDCLK	
VSYNC LOW PULSE WIDTH	tWV	2	4	—	Lines	
VERTICAL BACK PORCH	tVBP	2	18	127	Lines	
VERTICAL FRONT PORCH	tVFP	—	4	—	Lines	
VERTICAL DATA START POINT	tVBP	—	18	—	Lines	
VERTICAL BLANKING PERIOD	tVBP + tVFP	—	22	—	Lines	
VERTICAL BLANKING PERIOD	NTSC	10	22	47	Lines	
	PAL	20	33	120		
	PAL	12	25	112		
VERTICAL DISPLAY AREA	NTSC	—	240	—	Lines	
	PAL	VDISP	—	280(PALM=0)		—
			—	280(PALM=1)		—
VERTICAL CYCLE	NTSC	250	262	287	Lines	
	PAL	300	313	400		

DATA TRANSACTION TIMING IN NORMAL OPERATING MODE

5.3 PARALLEL RGB INTERFACE (DE MODE)

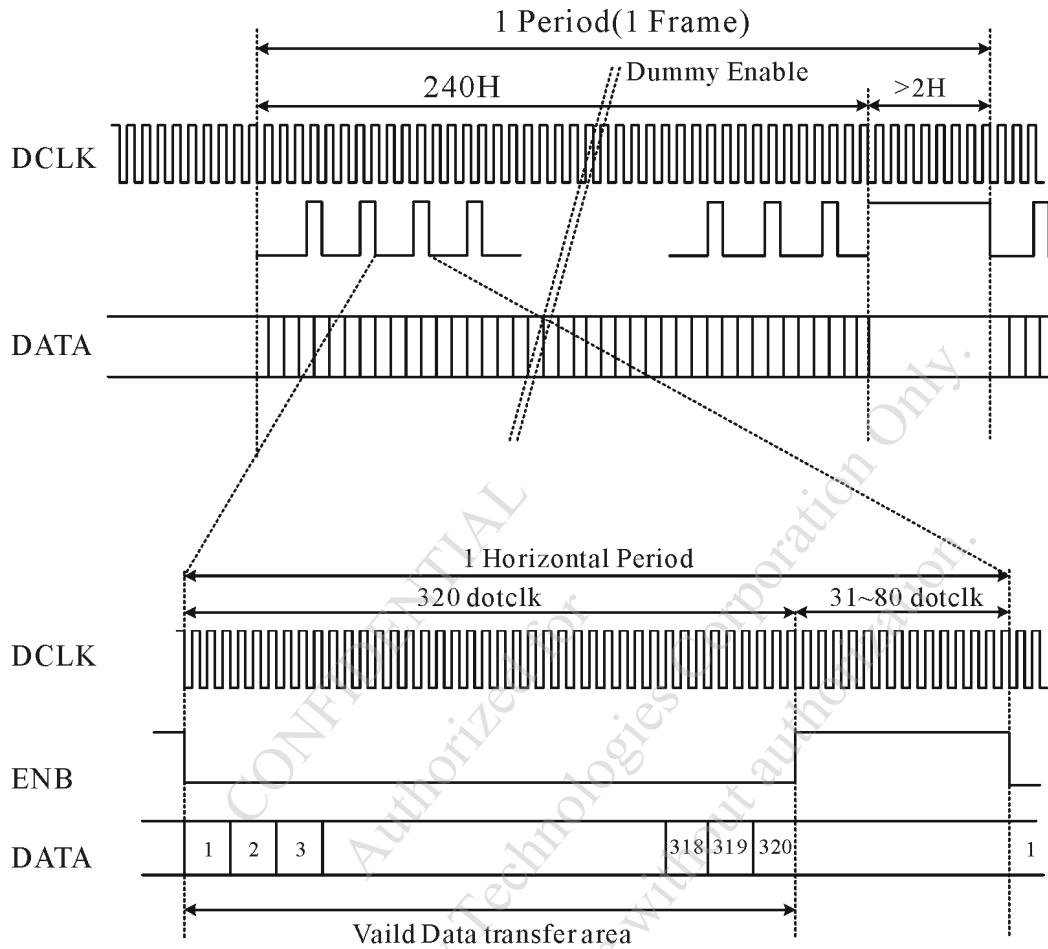

ITEM	SYMBOL	MIN.	TYP.	MAX.	UNIT
DOTCLK FREQUENCY	fDOTCLK	—	6.5	10	MHz
DOTCLK PERIOD	tDOTCLK	100	154	—	ns
HORIZONTAL BLANKING PERIOD	tHBP + tHFP	52	88	180	tDOTCLK
HORIZONTAL DISPLAY AREA	HDISP	—	320	—	tDOTCLK
HORIZONTAL CYCLE	Hcycle	372	408	500	tDOTCLK
VERTICAL BLANKING PERIOD	tVBP + tVFP	2	—	47	Lines
VERTICAL DISPLAY AREA	VDISP	—	240	—	Lines
VERTICAL CYCLE	Vcycle	242	—	287	Lines

DATA TRANSACTION TIMING IN DE ONLY OPERATING MODE

6. OPTICAL CHARACTERISTICS (NOTE 1)

6.1 OPTICAL CHARACTERISTICS

Ta = 25 ± 2°C

ITEM	SYMBOL	CONDITION	MIN.	TYP.	MAX.	UNIT	REMARK	
VIEWING ANGLE	θ_{y+}	CR ≥ 10	$\theta_x=0^\circ$	50	55	—	deg.	NOTE (2) NOTE (3)
	θ_{y-}			70	75	—		
	θ_{x+}		$\theta_y=0^\circ$	70	75	—		
	θ_{x-}			70	75	—		
CONTRAST RATIO	CR	$\theta_x=0^\circ, \theta_y=0^\circ$	350	450	—	—	NOTE (3)	
RESPONSE TIME	T _R (rise)	$\theta_x=0^\circ, \theta_y=0^\circ$	—	15	20	msec	NOTE (4)	
	T _F (fall)		—	35	50			
COLOR OF CIE COORDINATE	WHITE	W _x	$\theta_x=0^\circ, \theta_y=0^\circ$ IF=20mA NTSC : 60%	0.24	0.29	0.34	—	NOTE (6)
		W _y		0.28	0.33	0.38		
	RED	R _x		0.56	0.61	0.66		
		R _y		0.31	0.36	0.41		
	GREEN	G _x		0.28	0.33	0.38		
		G _y		0.56	0.61	0.66		
	BLUE	B _x		0.10	0.15	0.20		
		B _y		0.05	0.10	0.15		
THE BRIGHTNESS OF MODULE	B	$\theta_x=0^\circ, \theta_y=0^\circ$	450	500	—	cd/m ²	NOTE (5)	
THE UNIFORMITY OF BRIGHTNESS	—	IF=20mA	70	—	—	%	—	

NOTE (1) : TEST EQUIPMENT SETUP :

AFTER STABILIZING AND LEAVING THE PANEL ALONE AT A GIVEN TEMPERATURE FOR 30 MINUTES, THE MEASUREMENT SHOULD BE EXECUTED. MEASUREMENT SHOULD BE EXECUTED IN A STABLE, WINDLESS, AND DARK ROOM. OPTICAL SPECIFICATIONS ARE MEASURED BY TOPCON BM-7 (FAST) WITH A VIEWING ANGLE OF 1° AT A DISTANCE OF 50cm AND NORMAL DIRECTION.

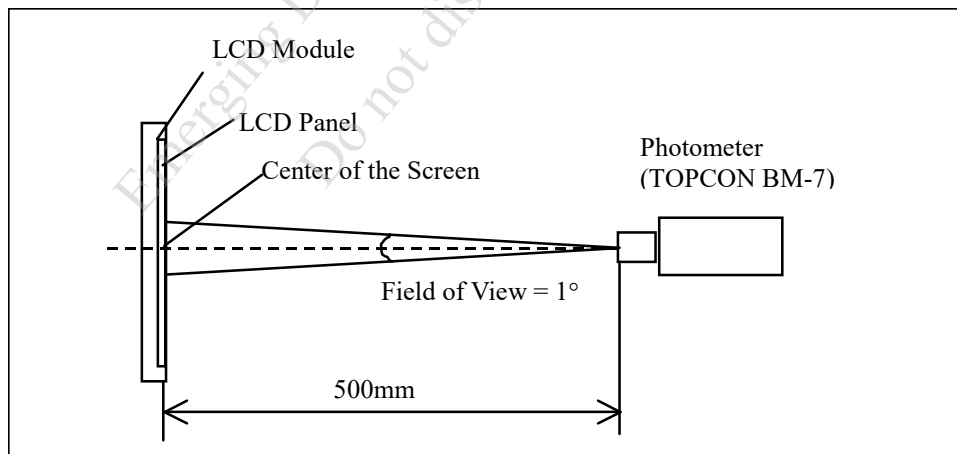

NOTE (2) : DEFINITION OF VIEWING ANGLE :

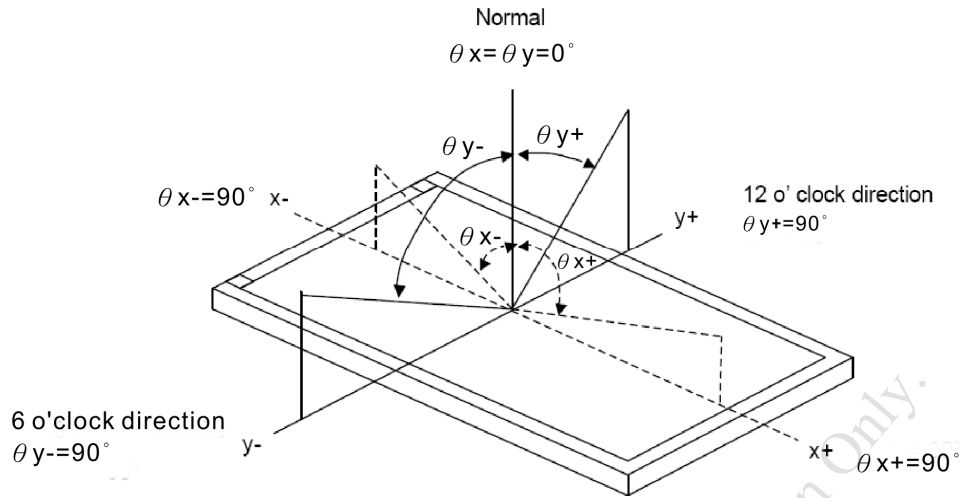

NOTE (3) : DEFINITION OF CONTRAST RATIO :

$$\text{CONTRAST RATIO(CR)} = \frac{\text{BRIGHTNESS MEASURED WHEN LCD IS AT "WHITE STATE"}}{\text{BRIGHTNESS MEASURED WHEN LCD IS AT "BLACK STATE"}}$$

NOTE (4) : DEFINITION OF RESPONSE TIME : T_R AND T_F

THE FIGURE BELOW IS THE OUTPUT SIGNAL OF THE PHOTO DETECTOR.

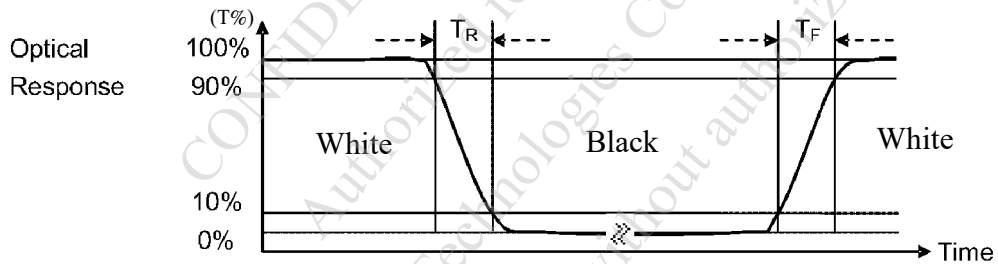

NOTE (5) : BRIGHTNESS MEASURED WHEN LCD IS AT "WHITE STATE"

NOTE (6) : THE 100% TRANSMISSION IS DEFINED AS THE TRANSMISSION OF LCD PANEL WHEN ALL THE INPUT TERMINALS OF MODULE ARE ELECTRICALLY OPENED.

6.2 THE TEST METHOD OF BRIGHTNESS AND UNIFORMITY

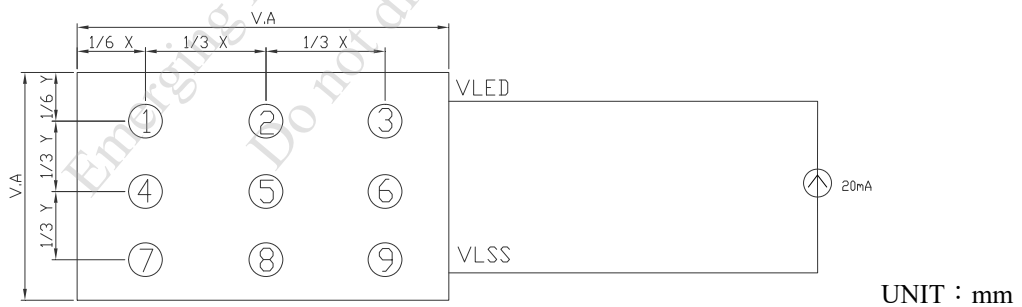

6.3 THE CALCULATING METHOD OF UNIFORMITY

$$\text{UNIFORMITY} = \left[1 - \frac{\text{MAXIMUM BRIGHTNESS} - \text{MINIMUM BRIGHTNESS}}{\text{AVERAGE BRIGHTNESS}} \right] \times 100\%$$

7. OUTLINE DIMENSIONS

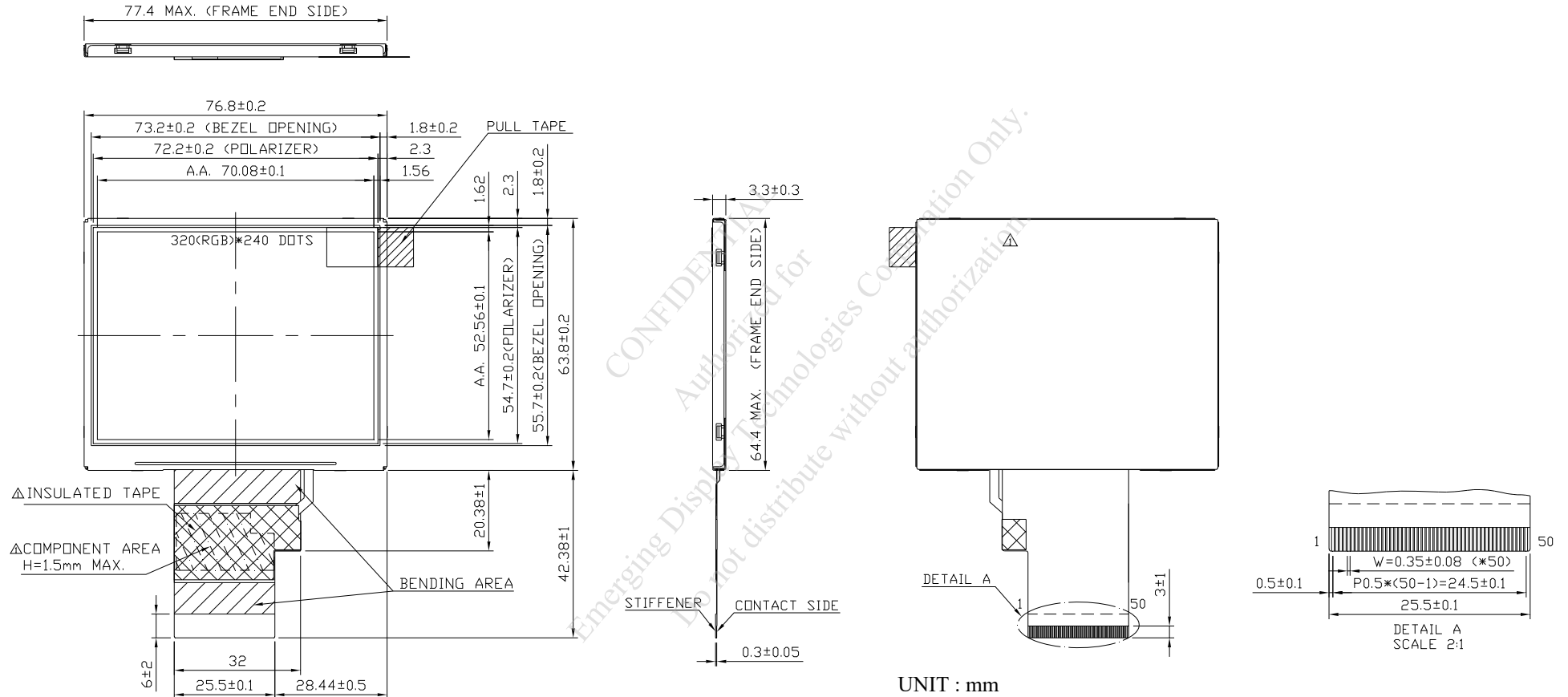

VIEWING DIRECTION

Best Contrast but with Gray Level Inversion

UNIT : mm
SCALE : NTS

THIRD ANGLE PROJECTION

NOT SPECIFIED TOLERANCE IS ± 0.3

MARK△MODIFY (NUMBER NOTE MODIFY VERSION)

NOTE:

RECOMMEND MATCH CONNECTOR KYOCERA:04 6299 050 SERIES

8. BLOCK DIMENSION

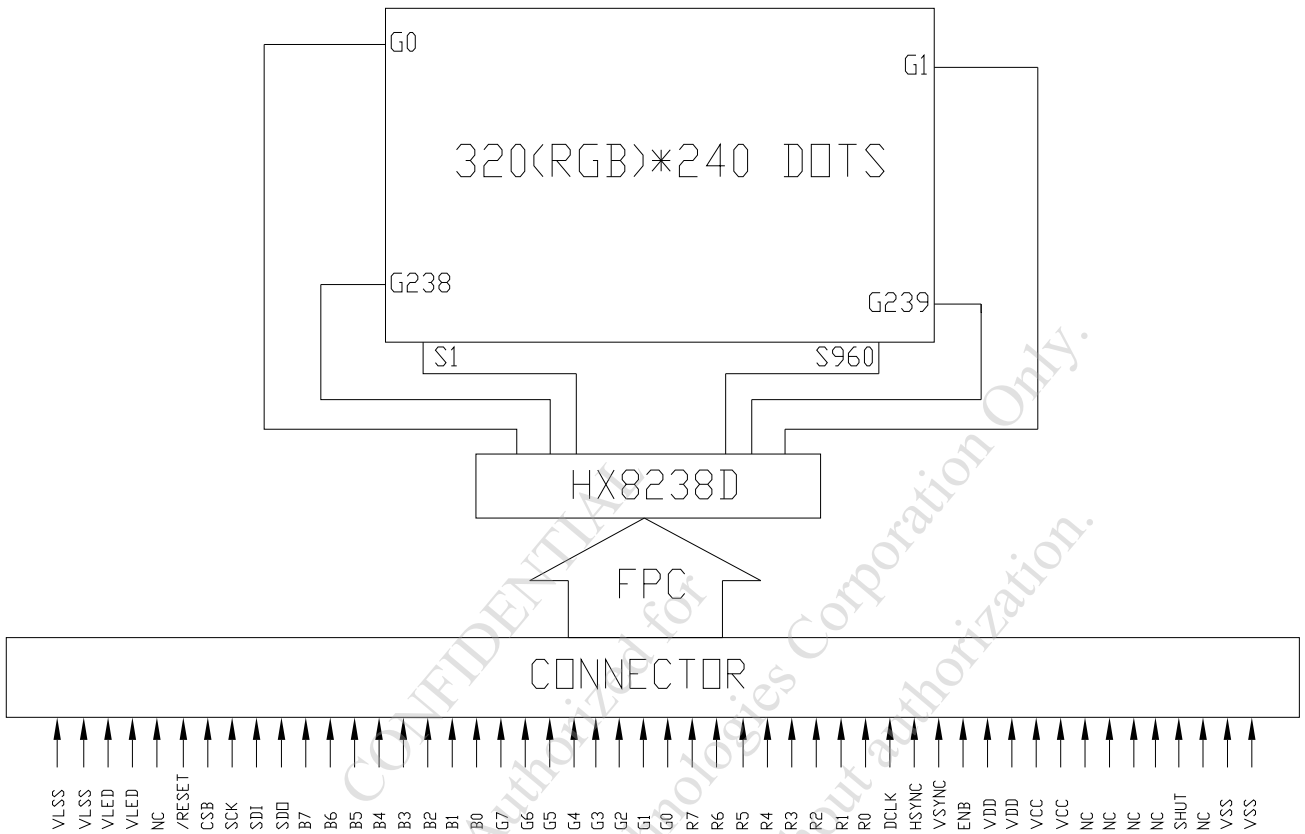

CONFIDENTIAL
Authorized for Emerging Display Technologies Corporation Only.
Do not distribute without authorization.

9. DETAIL DRAWING OF DOT MATRIX

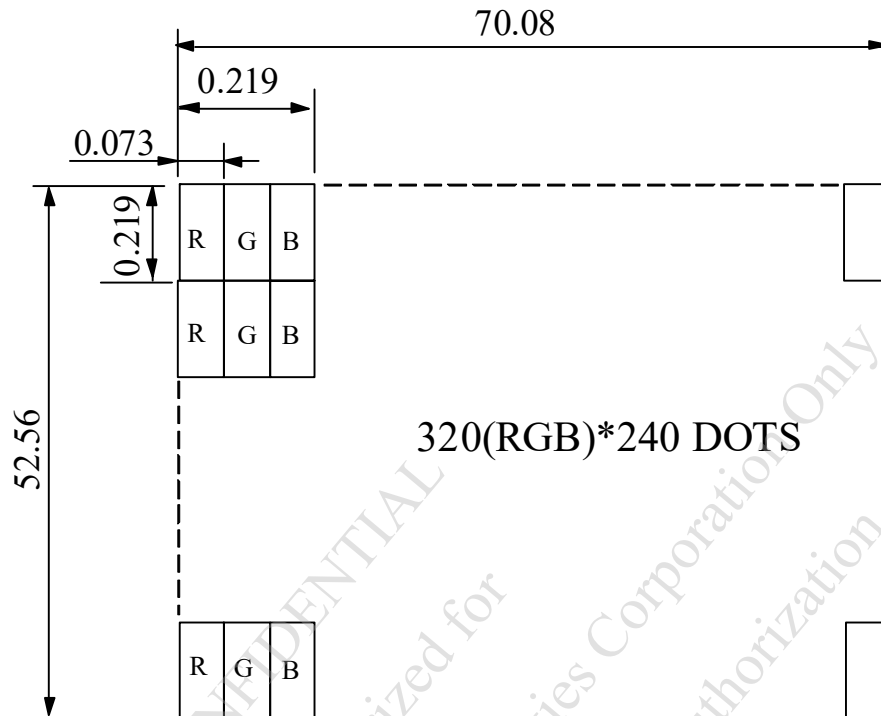

UNIT : mm

SCALE : NTS

NOT SPECIFIED TOLERANCE IS ± 0.1

DOTS MATRIX TOLERANCE IS ± 0.01

CONFIDENTIAL
Authorized for
Emerging Display Technologies Corporation Only
Do not distribute without authorization

10. INTERFACE SIGNALS

PIN NO.	SYMBOL	I/O/P	FUNCTION
1	VLSS	P	POWER SUPPLY FOR LED BACKLIGHT (CATHODE)
2	VLSS	P	POWER SUPPLY FOR LED BACKLIGHT (CATHODE)
3	VLED	P	POWER SUPPLY FOR LED BACKLIGHT (ANODE)
4	VLED	P	POWER SUPPLY FOR LED BACKLIGHT (ANODE)
5	NC	—	NON CONNECTION
6	/RESET	I	HARDWARE RESET
7	CSB	I	SPI INTERFACE CHIP SELECT BAR
8	SCK	I	SPI INTERFACE DATA CLOCK
9	SDI	I	SPI INTERFACE DATA (INPUT)
10	SDO	O	SPI INTERFACE DATA(OUTPUT)
11	B7	I	BLUE DATA BIT 7
12	B6	I	BLUE DATA BIT 6
13	B5	I	BLUE DATA BIT 5
14	B4	I	BLUE DATA BIT 4
15	B3	I	BLUE DATA BIT 3
16	B2	I	BLUE DATA BIT 2
17	B1	I	BLUE DATA BIT 1
18	B0	I	BLUE DATA BIT 0
19	G7	I	GREEN DATA BIT 7
20	G6	I	GREEN DATA BIT 6
21	G5	I	GREEN DATA BIT 5
22	G4	I	GREEN DATA BIT 4
23	G3	I	GREEN DATA BIT 3
24	G2	I	GREEN DATA BIT 2
25	G1	I	GREEN DATA BIT 1
26	G0	I	GREEN DATA BIT 0
27	R7	I	RED DATA BIT 7
28	R6	I	RED DATA BIT 6
29	R5	I	RED DATA BIT 5
30	R4	I	RED DATA BIT 4
31	R3	I	RED DATA BIT 3
32	R2	I	RED DATA BIT 2
33	R1	I	RED DATA BIT 1
34	R0	I	RED DATA BIT 0
35	DCLK	I	DOT DATA CLOCK

PIN NO.	SYMBOL	I/O/P	FUNCTION	
36	HSYNC	I	HORIZONTAL SYNC INPUT	DE MODE : HSYNC, VSYNC FLOATING SYNC MODE : ENB FLOATING
37	VSYNC	I	VERTICAL SYNC INPUT	
38	ENB	I	DATA ENABLE INPUT	
39	VDD	P	ANALOG POWER SUPPLY	
40	VDD	P	ANALOG POWER SUPPLY	
41	VCC	P	DIGITAL POWER SUPPLY	
42	VCC	P	DIGITAL POWER SUPPLY	
43	NC	—	NON CONNECTION	
44	NC	—	NON CONNECTION	
45	NC	—	NON CONNECTION	
46	NC	—	NON CONNECTION	
47	SHUT	I	DISPLAY SHUT DOWN PIN TO PUT THE DRIVER INTO SLEEP MODE. CONNECT TO VCC FOR SLEEP MODE. CONNECT TO VSS FOR NORMAL OPERATING MODE.	
48	NC	—	NON CONNECTION	
49	VSS	P	GROUND	
50	VSS	P	GROUND	

11. POWER SUPPLY

11.1 POWER SUPPLY FOR LCM

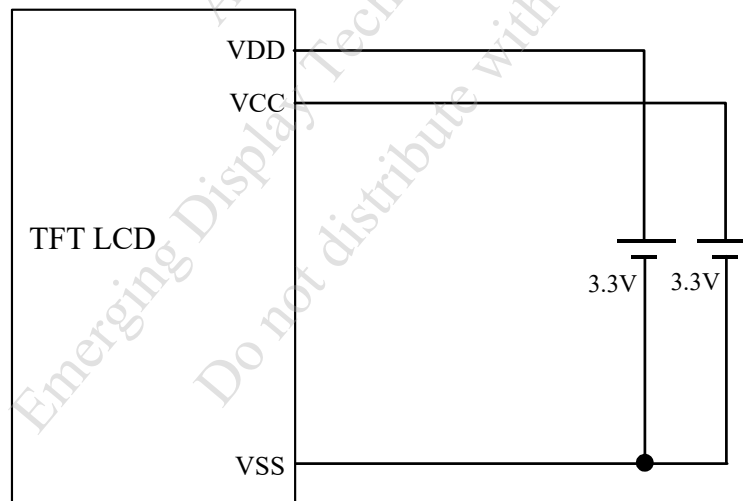

11.2 POWER SUPPLY FOR LED BACKLIGHT

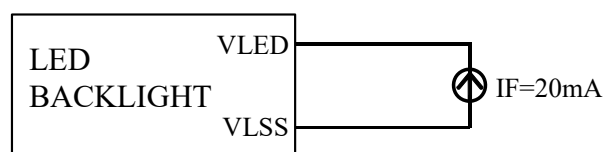

12. INSPECTION CRITERION

12.1 APPLICATION

THIS INSPECTION STANDARD IS TO BE APPLIED TO THE LCD MODULE DELIVERED FROM EMERGING DISPLAY TECHNOLOGIES CORP.(E.D.T) TO CUSTOMERS

12.2 INSPECTION CONDITIONS

12.2.1 (1)OBSERVATION DISTANCE : 45±5cm

(2)VIEW ANGLE : ±45°

PERPENDICULAR TO MODULE SURFACE

VIEWING ANGLE SHOULD BE SMALLER THAN 45°

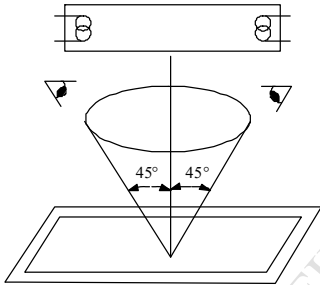

LINE OF SIGHT FOR INSPECTION SHALL BE WITHIN THE HALF SECTION OF THE VIEWING CONE GENERATED BY LINE SEGMENT 45° WITH RESPECTS TO THE VERTICAL AXIS FROM CENTER VERTEX OF LCD, THE CONE AXIS MUST BE PERPENDICULAR NORMAL TO LCD SURFACE AND PASSES THROUGH THE FLUORESCENT LAMP.

12.2.2 ENVIRONMENT CONDITIONS :

AMBIENT TEMPERATURE		25±5°C
AMBIENT HUMIDITY		65 ± 20%RH
AMBIENT ILLUMINATION	COSMETIC INSPECTION	600~800 lux
	FUNCTIONAL INSPECTION	300~500 lux
INSPECTION TIME		10 secs

12.2.3 INSPECTION LOT

QUANTITY PER DELIVERY LOT FOR EACH MODEL

12.2.4 A SAMPLING INSPECTION SHALL BE MADE ACCORDING TO THE FOLLOWING PROVISIONS TO JUDGE THE ACCEPTABILITY

(a)APPLICABLE STANDARD :

ANSI/ ASQ Z1.4 NORMAL INSPECTION LEVEL II

(b)AQL : MAJOR DEFECT : AQL 0.65

MINOR DEFECT : AQL 1.0

12.3 INSPECTION STANDARDS

12.3.1 VISUAL DEFECTS CLASSIFICATION

TYPE OF DEFECT	INSPECTION ITEM	DEFECT FEATURE	AQL
MAJOR DEFECT	1.DISPLAY ON	<ul style="list-style-type: none"> • DEFECT TO MISS SPECIFIED DISPLAY FUNCTION, FOR ALL AND SPECIFIED DOTS EX: DISCONNECTION, SHORT CIRCUIT ETC 	0.65
	2.BACKLIGHT	<ul style="list-style-type: none"> • NO LIGHT • FLICKERING AND OTHER ABNORMAL ILLUMINATION 	
	3.DIMENSIONS	<ul style="list-style-type: none"> • SUBJECT TO INDIVIDUAL ACCEPTANCE SPECIFICATIONS 	
MINOR DEFECT	1.DISPLAY ZONE	<ul style="list-style-type: none"> • BLACK/WHITE SPOT • BUBBLES ON POLARIZER • NEWTON RING • BLACK/WHITE LINE • SCRATCH • CONTAMINATION • UNEVEN COLOR SPREAD 	1.0
	2.BEZEL ZONE	<ul style="list-style-type: none"> • STAINS • SCRATCHES • FOREIGN MATTER 	
	3.SOLDERING	<ul style="list-style-type: none"> • INSUFFICIENT SOLDER • SOLDERED IN INCORRECT POSITION • CONVEX SOLDERING SPOT • SOLDER BALLS • SOLDER SCRAPS 	
	4.DISPLAY ON (ALL ON)	<ul style="list-style-type: none"> • LIGHT LINE 	

12.3.2 MODULE DEFECTS CLASSIFICATION

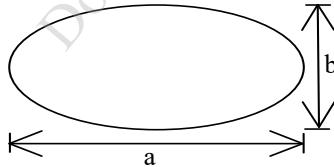
NO.	ITEM	CRITERIA												
1	DISPLAY ON INSPECTION	(1)INCORRECT PATTERN (2)MISSING SEGMENT (3)DIM SEGMENT (4)OPERATING VOLTAGE BEYOND SPEC												
2	OVERALL DIMENSIONS	(1)OVERALL DIMENSION BEYOND SPEC												
3	DOT DEFECT	(1)INSPECTION PATTERN: FULL WHITE, FULL BLACK, RED, GREEN AND BLUE SCREENS. (2) <table border="1" style="margin-left: 20px;"> <thead> <tr> <th>ITEMS</th> <th>ACCEPTABLE COUNT</th> </tr> </thead> <tbody> <tr> <td>BRIGHT DOT</td> <td>$N \leq 2$</td> </tr> <tr> <td>DARK DOT</td> <td>$N \leq 3$</td> </tr> <tr> <td>TOTAL BRIGHT AND DARK DOTS</td> <td>$N \leq 4$</td> </tr> </tbody> </table> <p>NOTE :</p> <p>1. THE DEFINITION OF DOT : THE SIZE OF A DEFECTIVE DOT OVER 1/2 OF WHOLE DOT IS REGARDED AS ONE DEFECTIVE DOT.</p> <p>2. BRIGHT DOT : DOTS APPEAR BRIGHT AND UNCHANGED IN SIZE IN WHICH LCD PANEL IS DISPLAYING UNDER BLACK PATTERN.</p> <p>3. DARK DOT : DOTS APPEAR DARK AND UNCHANGED IN SIZE IN WHICH LCD PANEL IS DISPLAYING UNDER PURE RED, GREEN, BLUE PICTURE.</p>	ITEMS	ACCEPTABLE COUNT	BRIGHT DOT	$N \leq 2$	DARK DOT	$N \leq 3$	TOTAL BRIGHT AND DARK DOTS	$N \leq 4$				
ITEMS	ACCEPTABLE COUNT													
BRIGHT DOT	$N \leq 2$													
DARK DOT	$N \leq 3$													
TOTAL BRIGHT AND DARK DOTS	$N \leq 4$													
4	FOREIGN BLACK/WHITE/ BRIGHT LINE/ SCRATCH OF VIEWING AREA	<table border="1" style="margin-left: 20px;"> <thead> <tr> <th>LENGTH : L</th> <th>WIDTH : W</th> <th>PERMISSIBLE NO.</th> </tr> </thead> <tbody> <tr> <td>$L \leq 0.3$</td> <td>$W \leq 0.05$</td> <td>IGNORE</td> </tr> <tr> <td>$0.3 < L \leq 2.5$</td> <td>$0.05 < W \leq 0.1$</td> <td>4</td> </tr> <tr> <td>$2.5 < L$</td> <td>$0.1 < W$</td> <td>NONE</td> </tr> </tbody> </table> <p>WIDTH : W mm, LENGTH : L mm</p>	LENGTH : L	WIDTH : W	PERMISSIBLE NO.	$L \leq 0.3$	$W \leq 0.05$	IGNORE	$0.3 < L \leq 2.5$	$0.05 < W \leq 0.1$	4	$2.5 < L$	$0.1 < W$	NONE
LENGTH : L	WIDTH : W	PERMISSIBLE NO.												
$L \leq 0.3$	$W \leq 0.05$	IGNORE												
$0.3 < L \leq 2.5$	$0.05 < W \leq 0.1$	4												
$2.5 < L$	$0.1 < W$	NONE												
5	FOREIGN MATTER \ BLACK SPOTS \ WHITE SPOTS \ DENT (INCLUDING LIGHT LEAKAGE DUE TO POLARIZING PLATES PINHOLES, ETC.)	<table border="1" style="margin-left: 20px;"> <thead> <tr> <th>AVERAGE DIAMETER (mm): D</th> <th>NUMBER OF PIECES PERMITTED</th> </tr> </thead> <tbody> <tr> <td>$D \leq 0.15$</td> <td>IGNORE</td> </tr> <tr> <td>$0.15 < D \leq 0.5$</td> <td>4</td> </tr> <tr> <td>$0.5 < D$</td> <td>NONE</td> </tr> </tbody> </table> <p>NOTE : DIAMETER $D=(a+b)/2$</p> 	AVERAGE DIAMETER (mm): D	NUMBER OF PIECES PERMITTED	$D \leq 0.15$	IGNORE	$0.15 < D \leq 0.5$	4	$0.5 < D$	NONE				
AVERAGE DIAMETER (mm): D	NUMBER OF PIECES PERMITTED													
$D \leq 0.15$	IGNORE													
$0.15 < D \leq 0.5$	4													
$0.5 < D$	NONE													

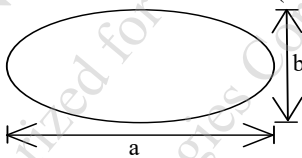
NO.	ITEM	CRITERIA		
			AVERAGE DIAMETER (mm) : D	NUMBER OF PIECES PERMITTED
6	BUBBLES OF POLARIZER /DIRT/CF FAIL /SURFACE STAINS	BUBBLE ON THE POLARIZER	$D \leq 0.25$	IGNORE
			$0.25 < D \leq 0.5$	$N \leq 5$
			$0.5 < D$	NONE
		SURFACE STAINS	$D < 0.1$	IGNORE
			$0.1 < D \leq 0.3$	$N \leq 3$
		CF FAIL / SPOT	$D < 0.1$	IGNORE
$0.1 < D \leq 0.3$	$N \leq 3$			
		<p>NOTE : (1)POLARIZER BUBBLE IS DEFINED AS THE BUBBLE APPEARS ON ACTIVE DISPLAY AREA. THE DEFECT OF POLARIZER BUBBLE SHALL BE IGNORED IF THE POLARIZER BUBBLE APPEARS ON THE OUTSIDE OF ACTIVE DISPLAY AREA.</p> <p>(2)THE EXTRANEIOUS SUBSTANCE IS DEFINED AS IT CAN BE OBSERVED WHEN THE MODULE IS POWER ON.</p> <p>(3)THE DEFINITION OF AVERAGE DIAMETER, D IS DEFINED AS FOLLOWING.</p> <p>AVERAGE DIAMETER (D)=(a+b)/2</p> 		
7	LINE DEFECT ON DISPLAY	OBVIOUS VERTICAL OR HORIZONTAL LINE DEFECT IS NOT ALLOWED		
8	MURA ON DISPLAY	IT'S OK IF MURA IS SLIGHT VISIBLE THROUGH 6% ND FILTER		
9	UNEVEN COLOR SPREAD, COLORATION	(1)TO BE DETERMINED BASED UPON THE STANDARD SAMPLE.		
10	BEZEL APPEARANCE	(1)BEZEL MAY NOT HAVE RUST, BE DEFORMED OR HAVE FINGER PRINTS STAINS OF OTHER CONTAMINATION. (2)BEZEL MUST COMPLY WITH JOB SPECIFICATIONS.		
11	PCB	<p>(1)THERE MAY NOT BE MORE THAN 2mm OF SEALANT OUTSIDE THE SEAL AREA ON THE PCB, AND THERE SHOULD BE NO MORE THAN THREE PLACES.</p> <p>(2)NO OXIDATION OR CONTAMINATION PCB TERMINALS.</p> <p>(3)PARTS ON PCB MUST BE THE SAME AS ON THE PRODUCTION CHARACTERISTIC CHART. THERE SHOULD BE NO WRONG PARTS, MISSING PARTS OR EXCESS PARTS.</p> <p>(4)THE JUMPER ON THE PCB SHOULD CONFORM TO THE PRODUCT CHARACTERISTIC CHART.</p> <p>(5)IF SOLDER GETS ON BEZEL TAB PADS, LED PAD, ZEBRA PAD OR SCREW HOLD PAD, MAKE SURE IT IS SMOOTHED DOWN.</p>		

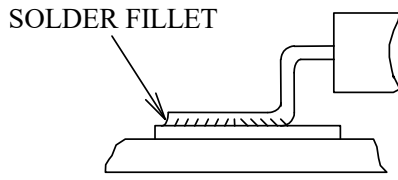
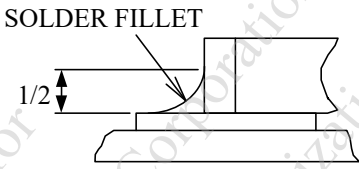
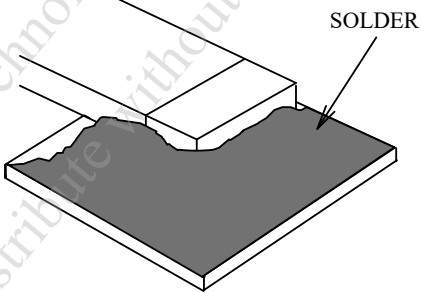
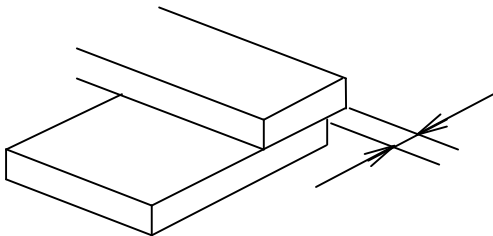
NO.	ITEM	CRITERIA
12	SOLDERING	<p>(1) NO SOLDERING FOUND ON THE SPECIFIED PLACE</p> <p>(2) INSUFFICIENT SOLDER</p> <p>(a) LSI, IC A POOR WETTING OF SOLDER IS BETWEEN LOWER BEND OR "HEEL" OF LEAD AND PAD</p>  <p>(b) CHIP COMPONENT · SOLDER IS LESS THAN 50% OF SIDES AND FRONT FACE WETTING</p>  <p>· SOLDER WETS 3 SIDES OF TERMINAL, BUT LESS THAN 25% OF SIDES AND FRONT SURFACE AREA ARE COVERED</p>  <p>(3) PARTS ALIGNMENT</p> <p>(a) LSI, IC LEAD WIDTH IS MORE THAN 50% BEYOND PAD OUTLINE</p> 

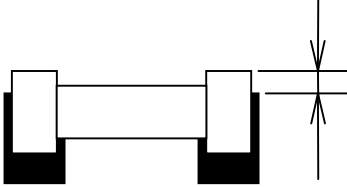
NO.	ITEM	CRITERIA
12	SOLDERING	<p>(b)CHIP COMPONENT COMPONENT IS OFF CENTER, AND MORE THAN 50% OF THE LEADS IS OFF THE PAD OUTLINE</p>  <p>(4)NO UNMELTED SOLDER PASTE MAY BE PRESENT ON THE PCB. (5)NO COLD SOLDER JOINTS, MISSING SOLDER CONNECTIONS, OXIDATION OR ICICLE. (6)NO RESIDUE OR SOLDER BALLS ON PCB. (7)NO SHORT CIRCUITS IN COMPONENTS ON PCB.</p>
13	BACKLIGHT	<p>(1)NO LIGHT (2)FLICKERING AND OTHER ABNORMAL ILLUMINATION (3)SPOTS OR SCRATCHES THAT APPEAR WHEN LIT MUST BE JUDGED USING LCD SPOT, LINES AND CONTAMINATION STANDARDS. (4)BACKLIGHT DOESN'T LIGHT OR COLOR IS WRONG.</p>
14	GENERAL APPEARANCE	<p>(1)NO OXIDATION, CONTAMINATION, CURVES OR, BENDS ON INTERFACE PIN (OLB) OF TCP. (2)NO CRACKS ON INTERFACE PIN (OLB) OF TCP. (3)NO CONTAMINATION, SOLDER RESIDUE OR SOLDER BALLS ON PRODUCT. (4)THE IC ON THE TCP MAY NOT BE DAMAGED, CIRCUITS. (5)THE UPPERMOST EDGE OF THE PROTECTIVE STRIP ON THE INTERFACE PIN MUST BE PRESENT OR LOOK AS IF IT CAUSE THE INTERFACE PIN TO SEVER. (6)THE RESIDUAL ROSIN OR TIN OIL OF SOLDERING (COMPONENT OR CHIP COMPONENT) IS NOT BURNED INTO BROWN OR BLACK COLOR. (7)SEALANT ON TOP OF THE ITO CIRCUIT HAS NOT HARDENED. (8)PIN TYPE MUST MATCH TYPE IN SPECIFICATION SHEET. (9)LCD PIN LOOSE OR MISSING PINS. (10)PRODUCT PACKAGING MUST THE SAME AS SPECIFIED ON PACKAGING SPECIFICATION SHEET. (11)PRODUCT DIMENSION AND STRUCTURE MUST CONFORM TO PRODUCT SPECIFICATION SHEET. (12)THE APPEARANCE OF HEAT SEAL SHOULD NOT ADMIT ANY DIRT AND BREAK.</p>

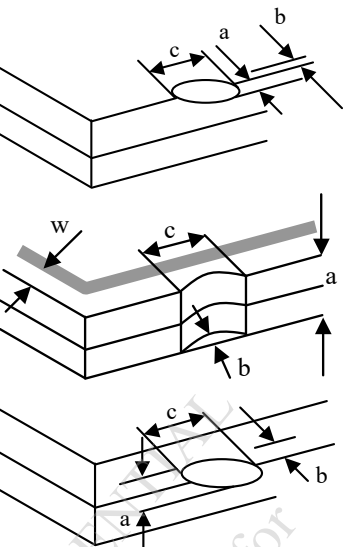
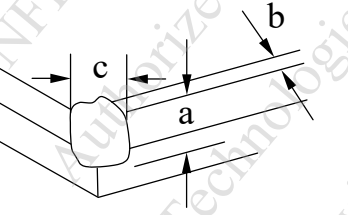
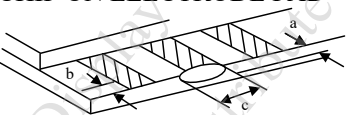
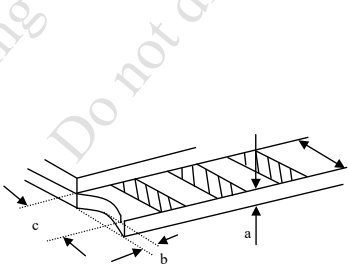
NO.	ITEM	CRITERIA										
15	CRACKED GLASS	<p>THE LCD WITH EXTENSIVE CRACK IS NOT ACCEPTABLE</p>										
		<p>GENERAL GLASS CHIP :</p> 	<table border="1" data-bbox="935 418 1458 495"> <thead> <tr> <th>a</th> <th>b</th> <th>c</th> </tr> </thead> <tbody> <tr> <td>$\leq t/2$</td> <td>< VIEWING AREA</td> <td>$\leq 1/8X$</td> </tr> <tr> <td>$t/2 >, \leq 2t$</td> <td>$\leq W/2$</td> <td>$\leq 1/8X$</td> </tr> </tbody> </table> <p>*W=DISTANCE BETWEEN SEALANT AREA AND LCD PANEL EDGE X = LCD SIDE LENGTH t = GLASS THICKNESS</p>	a	b	c	$\leq t/2$	< VIEWING AREA	$\leq 1/8X$	$t/2 >, \leq 2t$	$\leq W/2$	$\leq 1/8X$
		a	b	c								
		$\leq t/2$	< VIEWING AREA	$\leq 1/8X$								
		$t/2 >, \leq 2t$	$\leq W/2$	$\leq 1/8X$								
<p>CORNER PART :</p> 	<table border="1" data-bbox="935 1001 1458 1077"> <thead> <tr> <th>a</th> <th>b</th> <th>c</th> </tr> </thead> <tbody> <tr> <td>$\leq t/2$</td> <td>< VIEWING AREA</td> <td>$\leq 1/8X$</td> </tr> <tr> <td>$> t/2, \leq 2t$</td> <td>$\leq W/2$</td> <td>$\leq 1/8X$</td> </tr> </tbody> </table> <p>*W=DISTANCE BETWEEN SEALANT AREA AND LCD PANEL EDGE X = LCD SIDE LENGTH t = GLASS THICKNESS</p>	a	b	c	$\leq t/2$	< VIEWING AREA	$\leq 1/8X$	$> t/2, \leq 2t$	$\leq W/2$	$\leq 1/8X$		
a	b	c										
$\leq t/2$	< VIEWING AREA	$\leq 1/8X$										
$> t/2, \leq 2t$	$\leq W/2$	$\leq 1/8X$										
<p>CHIP ON ELECTRODE PAD</p> 	<table border="1" data-bbox="935 1274 1458 1328"> <thead> <tr> <th>a</th> <th>b</th> <th>c</th> </tr> </thead> <tbody> <tr> <td>$\leq t$</td> <td>$\leq 0.5\text{mm}$</td> <td>$\leq 1/8X$</td> </tr> </tbody> </table> <p>* X=LCD SIDE WIDTH t=GLASS THICKNESS</p>	a	b	c	$\leq t$	$\leq 0.5\text{mm}$	$\leq 1/8X$					
a	b	c										
$\leq t$	$\leq 0.5\text{mm}$	$\leq 1/8X$										
	<table border="1" data-bbox="935 1426 1458 1480"> <thead> <tr> <th>a</th> <th>b</th> <th>c</th> </tr> </thead> <tbody> <tr> <td>$\leq t$</td> <td>$\leq 1/8X$</td> <td>$\leq L$</td> </tr> </tbody> </table> <p>*X=LCD SIDE WIDTH t = GLASS THICKNESS L=ELECTRODE PAD LENGTH ①IF GLASS CHIPPING THE ITO TERMINAL, OVER 2/3 OF THE ITO MUST REMAIN AND BE, INSPECTED ACCORDING TO ELECTRODE TERMINAL SPECIFICATIONS ②IF THE PRODUCT WILL BE HEAT SEALED BY THE CUSTOMER, THE ALIGNMENT MARK MUST NOT BE DAMAGED</p>	a	b	c	$\leq t$	$\leq 1/8X$	$\leq L$					
a	b	c										
$\leq t$	$\leq 1/8X$	$\leq L$										

12.4 RELIABILITY TEST

12.4.1 STANDARD SPECIFICATIONS FOR RELIABILITY OF LCD MODULE

NO.	ITEM	DESCRIPTION
1	HIGH TEMPERATURE OPERATION	THE SAMPLE SHOULD BE ALLOWED TO STAND AT +70°C FOR 240 HRS
2	LOW TEMPERATURE OPERATION	THE SAMPLE SHOULD BE ALLOWED TO STAND AT -20°C FOR 240 HRS
3	HIGH TEMPERATURE STORAGE	THE SAMPLE SHOULD BE ALLOWED TO STAND AT +80°C FOR 240 HRS
4	LOW TEMPERATURE STORAGE	THE SAMPLE SHOULD BE ALLOWED TO STAND AT -30°C FOR 240 HRS
5	HIGH TEMPERATURE /HUMIDITY TEST STORAGE	THE SAMPLE SHOULD BE ALLOWED TO STAND AT 60°C , 90% RH 240 HRS
6	THERMAL SHOCK (NOT OPERATED)	<p>THE SAMPLE SHOULD BE ALLOWED TO STAND THE FOLLOWING 10 CYCLES OF OPERATION:</p> <p>The diagram shows a temperature profile for one cycle of thermal shock testing. It starts at -30°C, ramps up to +80°C in 30 minutes, holds at +80°C for 3 minutes, ramps down to -30°C in 30 minutes, and holds at -30°C for 3 minutes. The total duration of one cycle is 72 minutes.</p>
7	ESD (ELECTROSTATIC DISCHARGE) (NOT OPERATED)	AIR DISCHARGE ± 12KV CONTACT DISCHARGE ± 8KV (ACCORDING TO IEC-61000-4-2)

NOTE (1) : THE TEST SAMPLES HAVE RECOVERY TIME FOR 2 HOURS AT ROOM TEMPERATURE BEFORE THE FUNCTION CHECK. IN THE STANDARD CONDITIONS, THERE IS NO DISPLAY FUNCTION NG ISSUE OCCURRED.

12.5 TESTING CONDITIONS AND INSPECTION CRITERIA

FOR THE FINAL TEST THE TESTING SAMPLE MUST BE STORED AT ROOM TEMPERATURE FOR 24 HOURS, STANDARD SPECIFICATIONS FOR RELIABILITY HAVE BEEN EXECUTED IN ORDER TO ENSURE STABILITY.

NO.	ITEM	TEST MODEL	INSPECTION CRITERIA
1	CURRENT CONSUMPTION	REFER TO SPECIFICATION	THE CURRENT CONSUMPTION SHOULD CONFORM TO THE PRODUCT SPECIFICATION.
2	CONTRAST	REFER TO SPECIFICATION	AFTER THE TESTS HAVE BEEN EXECUTED, THE CONTRAST MUST BE LARGER THAN HALF OF ITS INITIAL VALUE PRIOR TO THE TESTS.
3	APPEARANCE	VISUAL INSPECTION	DEFECT FREE

12.6 OPERATION

- 12.6.1 DO NOT CONNECT OR DISCONNECT MODULES TO OR FROM THE MAIN SYSTEM WHILE POWER IS BEING SUPPLIED.
- 12.6.2 USE THE MODULE WITHIN SPECIFIED TEMPERATURE ; LOWER TEMPERATURE CAUSES THE RETARDATION OF BLINKING SPEED OF THE DISPLAY ; HIGHER TEMPERATURE MAKES OVERALL DISPLAY DISCOLOR . WHEN THE TEMPERATURE RETURNS TO NORMALITY, THE DISPLAY WILL OPERATE NORMALLY.
- 12.6.3 ADJUST THE LC DRIVING VOLTAGE TO OBTAIN THE OPTIMUM CONTRAST.
- 12.6.4 POWER ON SEQUENCE INPUT SIGNALS SHOULD NOT BE SUPPLIED TO LCD MODULE BEFORE POWER SUPPLY VOLTAGE IS APPLIED AND REACHES THE SPECIFIED VALUE.
IF ABOVE SEQUENCE IS NOT FOLLOWED , CMOS LSIS OF LCD MODULES MAY BE DAMAGED DUE TO LATCH - UP PROBLEM.
- 12.6.5 NOT ALLOWED TO INFLICT ANY EXTERNAL STRESS AND TO CAUSE ANY MECHANICAL INTERFERENCE ON THE BENDING AREA OF FPC DURING THE TAIL BENDING BACKWARDS!
DO NOT STRESS FPC AND IC ON THE MODULE!

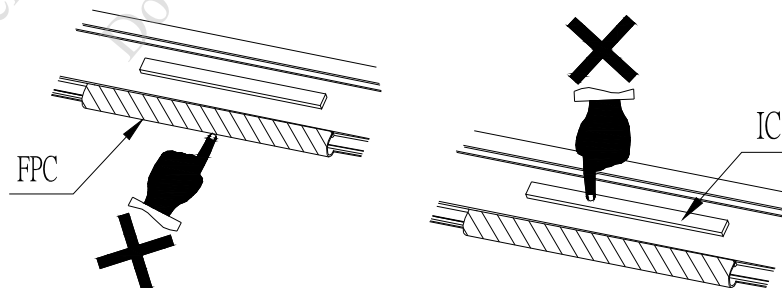

12.7 NOTICE

- 12.7.1 USE A GROUNDED SOLDERING IRON WHEN SOLDERING CONNECTOR I/O TERMINALS . FOR SOLDERING OR REPAIRING , TAKE PRECAUTION AGAINST THE TEMPERATURE OF THE SOLDERING IRON AND THE SOLDERING TIME TO PREVENT PEELING OFF THE THROUGH-HOLE-PAD .
- 12.7.2 DO NOT DISASSEMBLE . EDT SHALL NOT BE HELD RESPONSIBLE IF THE MODULE IS DISASSEMBLED AND UPON THE REASSEMBLY THE MODULE FAILED .
- 12.7.3 DO NOT CHARGE STATIC ELECTRICITY , AS THE CIRCUIT OF THIS MODULE CONTAINS CMOS LSIS. A WORKMAN'S BODY SHOULD ALWAYS BE STATIC-PROTECTED BY USE OF AN ESD STRAP. WORKING CLOTHES FOR SUCH PERSONNEL SHOULD BE OF STATIC-PROTECTED MATERIAL .
- 12.7.4 ALWAYS GROUND THE ELECTRICALLY-POWERED DRIVER BEFORE USING IT TO INSTALL THE LCD MODULE. WHILE CLEANING THE WORK STATION BY VACUUM CLEANER, DO NOT BRING THE SUCKING MOUTH NEAR THE MODULE ; STATIC ELECTRICITY OF THE ELECTRICALLY-POWERED DRIVER OR THE VACUUM CLEANER MAY DESTROY THE MODULE .
- 12.7.5 DON'T GIVE EXTERNAL SHOCK.
- 12.7.6 DON'T APPLY EXCESSIVE FORCE ON THE SURFACE.
- 12.7.7 LIQUID IN LCD IS HAZARDOUS SUBSTANCE. MUST NOT LICK AND SWALLOW.
WHEN THE LIQUID IS ATTACHED TO YOUR, SKIN, CLOTH ETC. WASH IT OUT THOROUGHLY AND IMMEDIATELY.
- 12.7.8 DON'T OPERATE IT ABOVE THE ABSOLUTE MAXIMUM RATING.
- 12.7.9 STORAGE IN A CLEAN ENVIRONMENT, FREE FROM DUST, ACTIVE GAS, AND SOLVENT.
- 12.7.10 STORE WITHOUT ANY PHYSICAL LOAD.
- 12.7.11 REWIRING : NO MORE THAN 3 TIMES.